

Alfa Laval LKHex UltraPure

Centrifugal pumps

Introduction

The Alfa Laval LKHex UltraPure Centrifugal Pump is a premium pump for use in high-purity applications which meets the requirements of the ATEX directive 2014/34/EU group II, category 2G, temperature class T3 and T4. To increase process productivity, it is distinguished by high efficiency, gentle product treatment, chemical resistance, and a wide range of flow rates, pressures and options.

Precision-engineered, the LKHex UltraPure pump delivers greater energy efficiency than similar pumps. Its optimized design, premium motor, tight tolerances and advanced impeller design minimize recirculation and reduce energy consumption.

Applications

The LKHex UltraPure is engineered for use in potentially explosive environments and conforms to the provisions of ATEX directive 2014/34/EU group II, category 2G, temperature class T3 and T4. Furthermore, the pump is designed to meet the stringent demands and regulations of high-purity applications across the biotechnology and pharmaceutical industries that require equipment with the highest material integrity.

All pumps are delivered with a complete Alfa Laval Q-doc package. Q-doc provides easier validation, proof of origin and compliance for inspection according to Good Manufacturing Practice (GMP) and ASME BPE requirements.

The LKH UltraPure pump is available in eight sizes to handle capacities up to 250 m³/h and differential pressures up to 10 bar at 50 Hz.

Benefits

- Energy efficient: superior efficiency resulting in reduced energy consumption and CO₂ footprint.
- Low contamination risk: comes with full material traceability and USP Class VI elastomers to reduce risk of process contamination from extractables.
- Conforms to the provisions of ATEX directive: can be used in potentially explosive environments.
- Smooth qualification, validation and process control: material traceability, and pump supplied with the Alfa Laval Q-doc package in line with Good Documentation Practices (GDP).

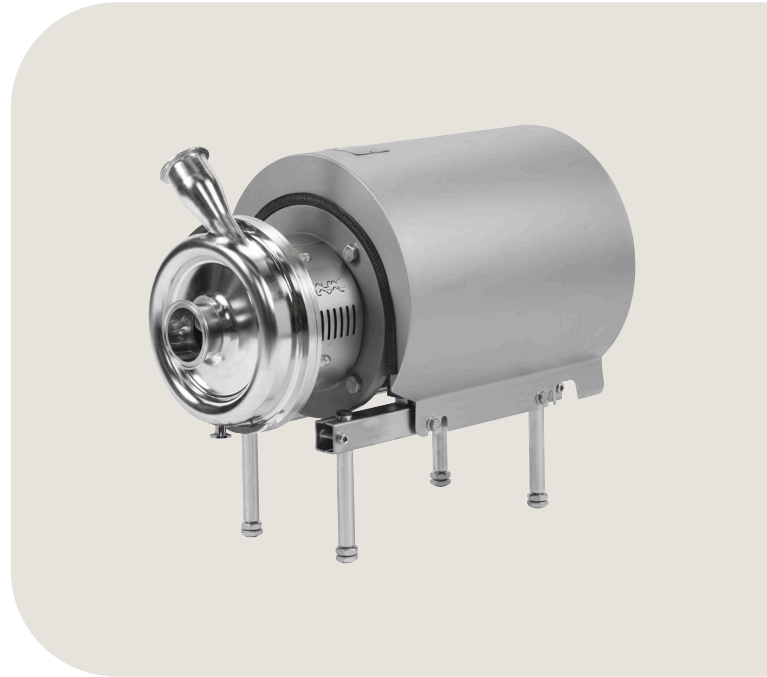

Standard design

All media contacting steel components like pump casing, impeller, impeller nut and backplate are in W. 1.4404 (AISI 316L) with material traceability 3.1 according to EN 10204. Product wetted elastomers are specified to USP Class VI, 121°C, Chapter 88 and Chapter 87. A stainless steel shroud protects the motor and four adjustable stainless steel legs support the complete unit.

A compression coupling securely attaches the stub shaft to the motor shaft with precision alignment, and the semi-open impeller with a special vane design ensures efficient and gentle handling of the product as it moves through the pump.

As standard, the LKHex UltraPure pump is equipped with a single mechanical shaft seal, but is also available with a double mechanical shaft seal. The front-loading shaft seal, with the spring and washers mounted on the atmospheric side, makes maintenance fast, easy and inexpensive. It takes just a few minutes to replace the shaft seal. In addition, the balanced design minimizes the risk of seal opening during unforeseen pressure shock.

Certificates



TECHNICAL DATA

Materials

Product wetted steel parts:	W. 1.4404 (316L) with material traceability 3.1 according to EN 10204
Other steel parts:	Stainless steel
Inside surface finish:	Mech Ra ≤ 0.5
External finish:	Fiber brushed
Product wetted elastomers:	EPDM - USP Class VI, 121°C. Chapter 88, and Chapter 87
Rotary seal face:	Silicon Carbide
Stationary seal face:	Silicon Carbide

Motor

Foot-flanged ATEX approved motor according to the IEC metric standard, 2 poles = 3000/3600 rpm. at 50/60 Hz.

Motor sizes

50Hz:	1.5 - 75 kW
60Hz:	1.5 - 75 kW

Warranty

Extended 3-years warranty on LKHex UltraPure pumps. The warranty covers all non wear parts on the condition that genuine Alfa Laval Spare Parts are used.

OPERATING DATA

Max. inlet pressure

LKHex UltraPure 10 - 70:	500kPa (5 bar)
--------------------------	----------------

Temperature, Class T4

Product temperature:	-10°C to +100°C (EPDM; FPM, FEP)
Ambient temperature, without shroud:	-20°C to +40°C
Ambient temperature, with shroud (<18.5kW):	-20°C to +35°C

Temperature, Class T3

Product temperature:	-10°C to +130°C (EPDM) / -10°C to +140°C (FPM, FEP)
Ambient temperature:	-20°C to +40°C

Double mechanical shaft seal

Water pressure inlet, LKHex UltraPure 10 - 60:	Max. 500 kPa (5 bar)
Water pressure inlet, LKHex UltraPure 70:	Max. 300 kPa (3 bar)
Water consumption:	0.5 l/min.

Connections for double mechanical shaft seal

LKHex UltraPure 10 - 70:	1/8" G
--------------------------	--------

Dimensions (mm)

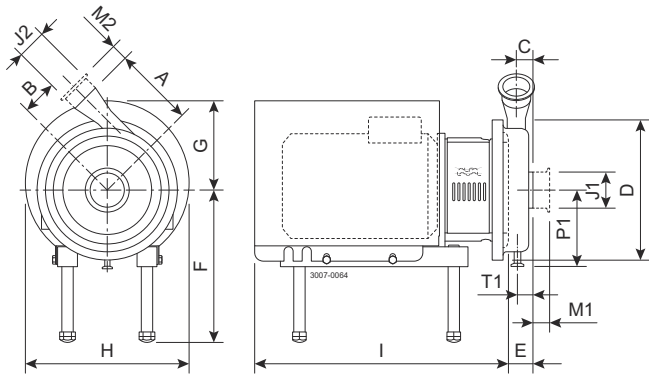

Pump specific measures

Pump Model	LKHex UltraPure-10	LKHex UltraPure-20	LKHex UltraPure-25	LKHex UltraPure-35	LKHex UltraPure-40	LKHex UltraPure-45	LKHex UltraPure-60	LKHex UltraPure-70
A	142	180	193	193	212	193	261	254
B	87	88	106	119	126	97	102	147
C	23	27	32	23	28	41	62	25
D	247	253	303	303	329	329	329	408
E	51	63	69	54	64	64	106	76
P1	123	129	153	153	166	153	165	206
T1	23	23	24	26	24	28	47	11

Motor specific measures Exd/Exde

Motor IEC	IEC90	IEC100	IEC112	IEC132	IEC160	IEC180	IEC200	IEC250
Motor kW	1.85kW	2.5kW	3.3kW	4.6kW	7.5-12.5kW	15kW	20-24kW	36kW
F(max.) ¹	262	282	285	304	332	352	372	446
G	243	242	198	196	262	286	399	394
H	365	383	359	383	485	533	670	738
I (LKHex Ultra Pure-10 to LKHex Ultra Pure-60)	445	493	497	597	791	842	980	-
I (LKHex Ultrapure-70)	-	-	-	-	804	855	993	1051

¹ Possible to reduce dimension F by min. 59 mm for all pump models. For smaller models it will be possible to reduce dimension F even further.

Motor overview Exe

Pump Model	LKHex UltraPure-10	LKHex UltraPure-20	LKHex UltraPure-25	LKHex UltraPure-35	LKHex UltraPure-40	LKHex UltraPure-45	LKHex UltraPure-60	LKHex UltraPure-70
Motor range (IEC)	IEC90-IEC132	IEC90-IEC160	IEC132-IEC180	IEC112-IEC160	IEC132-IEC180	IEC132-IEC180	IEC132-IEC200	IEC160-IEC280

Motor overview Exd/Exde

Pump Model	LKHex UltraPure-10	LKHex UltraPure-20	LKHex UltraPure-25	LKHex UltraPure-35	LKHex UltraPure-40	LKHex UltraPure-45	LKHex UltraPure-60	LKHex UltraPure-70
Motor range (IEC)	IEC90-IEC112	IEC90-IEC132	IEC112-IEC160	IEC132-IEC180	IEC160-IEC200	IEC112-IEC160	IEC132-IEC200	IEC160-IEC250



Note! Dimensional data are based on 2 pole, ABB motors.

Connections

Pump Model	LKHex UltraPure-10	LKHex UltraPure-20	LKHex UltraPure-25	LKHex UltraPure-35	LKHex UltraPure-40	LKHex UltraPure-45	LKHex UltraPure-60	LKHex UltraPure-70
Clamp ISO 1127	M1	36	48	48	92	92		
	M2	36	36	36	48	92		
Clamp ASME BPE	M1	29	29	29	29	29		
	M2	29	29	29	29	29		
Clamp ISO 2037	M1	21	21	21	21	21		
	M2	21	21	21	21	21		

¹ Other dimensions available on request.

Pump Model		LKHex UltraPure-10	LKHex UltraPure-25	LKHex UltraPure-40	LKHex UltraPure-45	LKHex UltraPure-60
		LKHex UltraPure-20	LKHex UltraPure-35	LKHex UltraPure-70		
Clamp DIN 32676	M1	64	64	64	92	92
	M2	21	64	21	64	92
Flange Asept. A for DIN	M1	64	96	96	60	60
	M2	47	64	47	96	60
Flange Asept. A for ASME	M1	56	58	58	60	60
	M2	47	56	47	58	60
Union Asept. A for DIN	M1	100	100	100	64	64
	M2	48	100	48	100	64
Union Asept. A for ASME	M1	60	54	54	64	64
	M2	48	60	48	54	64
J1 ¹		63,5 / 2,5"	76,1 / 3"	76,1 / 3"	101,6 / 4"	101,6 / 4"
J2 ¹		51 / 2"	63,5 / 2,5"	51 / 2"	76,1 / 3"	101,6 / 4"

¹ Other dimensions available on request.

Drain diameter

	ISO 1127 Clamp	TC Clamp
1/2"	13.5	12.7
3/4"	17.2	19



Note! Dimensions are for guidance only. For exact measures of specific pump specifications, please refer to Anytime Configurator. 900717/1

Flow chart

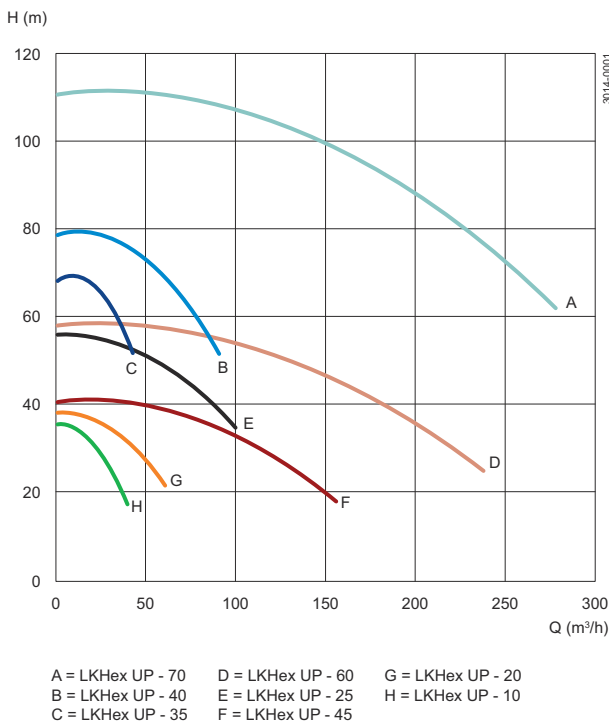

Figure 1. Frequency: 50Hz - Speed (synchr): 3000 rpm

Q-doc

Standard documentation package:

- Declaration of compliance with Regulation (EC) No.: 1935/2004.
- Declaration of compliance to EN 10204 type 3.1 (MTR).
- Declaration of compliance to the U.S. Food & Drug Administration CFR 21 (non-metallic parts).
- Declaration of compliance to the U.S. Pharmacopeia (Elastomers and polymers).
- TSE (Transmissible Spongiform Encephalopathy) / ADI (Animal Derivative Ingredient) declaration.
- Declaration of surface finish compliance.

- Declaration of passivation and electro polishing (if specified).
- 3.1 certification in accordance to EN10204.
- Pump performance test certificate.

Optional documentation:

- Hydrostatic test certificate.
- Surface measurement report.
- Delta ferrite report (impeller).

Options

- Impeller with reduced diameter.
- Impeller with delta ferrite max. 1%.
- Double mechanical shaft seal.
- Adjustable pads.
- Horizontal drain connection, see illustration below.
- No drain.
- Product wetted surface finish mechanically polished to $Ra \leq 0.8 \mu m$.
- Product wetted surface finish electropolished to $Ra \leq 0.4 \mu m$.
- Passivated surface.
- Product wetted elastomers FPM or FEP to USP Class VI, 121°C Chapter 88, and Chapter 87.
- Hydrostatic testing with certificate.
- Surface finish measurement with certificate.
- 0°, 90° or 270° outlet, see illustration below.

Available outlet positions

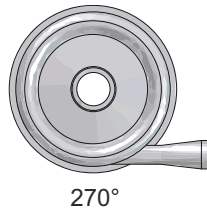
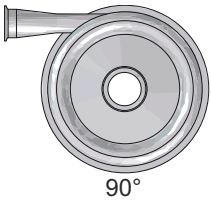
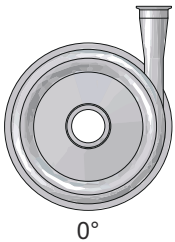

Available drain connections

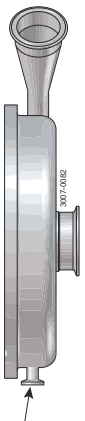

- 1/2" or 3/4" vertical drain:
- Tri-clamp for ASME
 - Clamp for ISO 1127

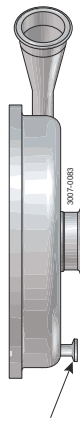

- 1/2" or 3/4" horizontal drain:
- Tri-clamp for ASME
 - Clamp for ISO 1127
 - Clamp for DIN 11864-3

Ordering

Please state the following when ordering:

- Pump size.
- Connections.
- Impeller diameter.
- Motor size.
- Voltage and frequency.
- Flow, pressure and temperature.
- Density and viscosity of the product.
- Options.



Note! For further details, see also instruction manual 100000157. This product has EHEDG certificate.

This document and its contents are subject to copyrights and other intellectual property rights owned by Alfa Laval Corporate AB. No part of this document may be copied, re-produced or transmitted in any form or by any means, or for any purpose, without Alfa Laval Corporate AB's prior express written permission. Information and services provided in this document are made as a benefit and service to the user, and no representations or warranties are made about the accuracy or suitability of this information and these services for any purpose. All rights are reserved.

How to contact Alfa Laval

Up-to-date Alfa Laval contact details for all countries are always available on our website at www.alfalaval.com