

Operating instructions

Cleanox 2.0 **EP-01-020**

Cleanox 4.0 **EP-01-040**

Cleanox 4.2 **EP-01-042**

Electrochemical cleaning, polishing and marking



2017-01-16 Rev.0	REUTER GmbH & Co. KG Schimmelbuschstr. 9e 40699 Erkrath Tel.: +49(0)211-73060-430 Fax: +49(0)211-73060-477 mail@reuter.de
www.reuter.de	

Table of contents

1 Introduction	4
1.1 Validity of these operating instructions	4
1.2 Target group for these operating instructions	4
1.3 Compliance with the operating instructions	4
1.4 EC and VDE (<i>Verband Deutscher Elektrotechniker</i> – German Electrotechnology Federation) directives	5
1.5 Accident prevention (UVV (<i>Unfallverhütungsvorschriften</i> - accident prevention regulations))	5
2 For your safety	6
2.1 Convention	6
2.1.1 Pictograms	6
2.1.2 Presentation	6
2.1.3 Warning signs	7
2.1.4 Prohibition signs	7
2.1.5 Mandatory signs	7
2.1.6 Information signs	7
2.2 Safety measures in the event of failure	8
2.2.1 Safety-relevant environmental conditions	8
2.3 Potential sources of danger and protective measures	9
2.3.1 Potential sources of danger	9
2.3.2 Protection measures	10
2.3.3 Before starting work, check	11
2.4 Potential misuses	11
2.5 Residual risks	11
3 Demands on personnel and operators	12
3.1 Users	12
3.2 Operator	12
4 Warranty and liability	12
4.1 Material defects	13
5 Technical terms	13
6 Delivery, in-house transport, unpacking	14
6.1 Delivery	14
6.2 Unloading	15
6.3 In-house transport	15
6.4 Unpacking	15
6.4.1 Opening the Euro plastic box	15
7 Scope of delivery of the "Cleanox" appliance set	16
7.1 Delivery list, "Cleanox" cleaning set	16
8 Storage requirements	18
9 Installation conditions	18
9.1 Safety	18
10 Decommissioning / storage	18
11 Storage	18
12 Appliance technology	19
12.1 Applications	19
13 Controls and operating elements on the front panel I	20
13.1 Automatic circuit breaker (overload FUSE)	20
13.2 High current jacks	21
13.3 Elements on the back panel	21
14 Accessories	22
14.1 Teflon handle with cable and plug	22
14.2 Earth clip with cable and plug	22
14.3 Carbon fibre brush XL	23
14.4 Assembly carbon fibre brush XL / Teflon handle	23
14.4.1 Adjusting the Teflon sliding sheath	24
14.5 Electrolyte	24
14.5.1 Transferring into the wide-mouth container	25
14.5.2 Information concerning non-toxicity	25
14.5.3 Information concerning the scope of delivery	26
15 Commissioning	26

16 Connection	26
16.1 Mains connection	26
16.2 Connecting the Teflon handle with the carbon fibre brush	27
16.3 Earth clip connection	27
16.3.1 Lock / release high-current plug	27
16.3.2 Releasing the high-current plug	28
17 Working with the "Cleanox"	28
18 Cleaning with the carbon fibre brush	29
18.1 Preparation	29
18.2 Workflow, cleaning with carbon fibre brush	29
18.3 Intensive cleaning with carbon fibre brush (only Cleanox 4.2)	32
18.3.1 Preparation	32
18.3.2 Workflow, strong cleaning	32
18.4 Polishing with the carbon fibre brush	33
18.4.1 Preparation	33
18.4.2 Workflow, polishing	33
19 Marking / Labelling (optional)	36
19.1 Marking set in case (optional)	37
19.2 Cable 1.5mm ² with 4mm safety plug	37
19.3 Marking stamp	38
19.4 Connecting the marking stamp	38
19.5 Changing the marking felt	38
19.6 Templates	39
19.6.1 Short-term templates	39
19.6.2 Long-term templates	39
19.7 Dark marking	39
19.8 Light marking	42
19.9 Tips for optimal marking / labelling	43
20 Possible faults and their remedies	44
21 Technical Data	45
22 Clean container, handles and workplace	45
23 Maintenance	46
23.1 Inspection and maintenance schedule	46
23.2 Disposal	47
23.3 Disposal of contaminated electrolytes	47
23.4 Disposal of electronic waste	47
24 Ordering spare and wear parts	47
25 Optional accessories	47
25.1 Teflon sliding sheath	47
25.2 Assembly	48
25.3 2 and 4-fold brush	48
25.4 Extension	49
25.5 Knee piece	50
25.6 Adapter brush	50
25.7 Printer	51
26 EC - Declaration of Conformity	52

1 Introduction

Thank you for choosing the "Cleanox" electrochemical high-current brush weld cleaner made by REUTER GmbH & Co. KG.

The purpose of this manual is to provide you with information concerning the safe handling and operation of the "Cleanox" as well as general information on cleaning and marking.

The user is given information concerning basic concepts and applications, as well as practical advice and help in the selection of settings, so that operating errors can be avoided.

Your specialist dealer will be happy to support and advise you with regard to commissioning, applications or problems.

Our telephone hotline is always available with expert advice on +49 (0) 171-5450200.

Please read through these operating instructions carefully before commissioning.

We hope you enjoy working with our appliances and wish you every success.

1.1 Validity of these operating instructions

These operating instructions apply to the following appliances:

- Cleanox 2.0 EP-01-020
- Cleanox 4.0 EP-01-040
- Cleanox 4.2 EP-01-042

Type-specific differences are identified and described accordingly.

1.2 Target group for these operating instructions

These operating instructions are intended for those operating and using the "Cleanox".

Familiarise yourself thoroughly with these instructions before using the "Cleanox". You will achieve better results and work safely.

If you have any difficulties or questions please contact our Customer Service, who will be happy to assist you.

We reserve the right to make technical changes that help to improve our electrochemical processing appliances.

1.3 Compliance with the operating instructions

These operating instructions are a constituent of the "Cleanox" and can be downloaded from our website under the "Download" menu. Alternatively, you can scan the QR code on the Quick Start Guide with your smartphone and receive the operating instructions as a PDF document.

These operating instructions must be available to the operating personnel at all times.

These operating instructions must be read by the operating personnel before commissioning the "Cleanox".

The operating personnel must have understood the content of the operating instructions before commissioning the "Cleanox".

If the "Cleanox" is passed on or resold, all operating instructions belonging to the appliance as well as any relevant documentation must be given to the new owner.

1.4 EC and VDE (*Verband Deutscher Elektrotechniker – German Electrotechnology Federation*) directives

Our electrochemical high current brush weld cleaner, "Cleanox", has been EMC-tested and certified at the accredited laboratory of the International Approval Center of Mitsubishi Electric in Dusseldorf.

We would be happy to send you a copy of the EMC investigation reports.

This electrochemical processing appliance complies with the certificate of conformity "CE":

- EC directive 2004/108/EC (EMC directive)
- EC Directive 2006/95/EC (Low Voltage Directive)



This electrochemical processing appliance was made in accordance with:

- EN 61558-1 (VDE 0570)

1.5 Accident prevention (*UVV (Unfallverhütungsvorschriften - accident prevention regulations)*)

- **Dangers may be caused by:**
 - Electrical currents
 - Pollutants
 - Gases
 - Electrolytes
- Read our safety data sheets concerning the electrolytes used by us.
- Observe the danger warnings.
- Note the following UVV regulations and information:
 - DGUV 1 (*Deutsche Gesetzliche Unfallversicherung - German Social Accident Insurance*) Principles of prevention
 - DGUV 3 Electrical systems and equipment
 - DGUV 4 Electrical systems and equipment
 - DGUV 6 Occupational health care
 - DGUV 9 Health and safety signs at work
 - DGUV 209-073 Workplace ventilation decision support for operational practice
 - DGUV 204-007 First aid manual
 - DGUV 204-022 First aid at work
 - DGUV 251-003 Contemporary occupational safety
 - SDS's Safety data sheets

Note

As of 01/05/2014, all UVV (*Unfallverhütungsvorschriften - accident prevention regulations*) rules and regulations have been renumbered and renamed.

Abbreviations such as: BGV / GUV-V, BGR / GUV-R, BGI / GUV-I / BGG / GUV-G or GUV-SI are no longer used.

The publications are consistently divided into four categories.

- DGUV Regulations
- DGUV Rules
- DGUV Information
- DGUV Principles

For detailed information see www.dguv.de, for example



2 For your safety

Read the operating instructions carefully. In the following chapter, the pictograms used in these operating instructions are explained.

2.1 Convention

2.1.1 Pictograms

The pictograms used in these operating instructions have the following meanings:

Warning signs

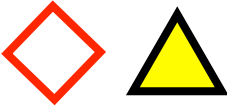

- Indicate possible hazards in the handling of the appliance and accessories.
- Warning signs are identified by a yellow triangle with a black border, or white square with a red border and a symbol at the centre, which indicates a specific hazard situation.

Prohibition signs



- Indicate possible prohibitions in the handling of the appliance and accessories
- Warning signs are identified by a white circular area with a red border and a symbol at the centre, which indicates a specific prohibition.

Mandatory signs



- Indicate mandatory use of protective equipment.
- Mandatory signs are identified by a blue circular area with a thin black border and a symbol at the centre, which indicates a specific requirement e.g.: wearing protective clothing

Information signs



- Indicate sections of these operating instructions which demand special attention.

2.1.2 Presentation

All normal descriptions in these operating instructions are written in the standard font size "Arial 10".

- Safety precautions which must be particularly observed are presented as shown in the following example:

Safety information

The relevant text is written here...

- Tips that facilitate working with or handling the appliance or accessories are presented as shown in the following example:



Tip

The relevant text is written here...

2.1.3 Warning signs



Warning of electromagnetic field



Warning of hot surface



Warning of explosive substances



Warning of harmful substances



Warning of dangerous electrical voltage



Warning of danger to life and limb



"Caution" warning of caustic chemicals

2.1.4 Prohibition signs



Prohibition for persons with cardiac pacemakers

2.1.5 Mandatory signs



Use eye protection



Use protective gloves



Disconnect power supply before opening



Use protective clothing

2.1.6 Information signs



Information concerning general sources of danger. Read this section carefully!



Information concerning tips or important information about working with the "Cleanox" and accessories. Read this section carefully!

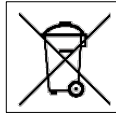

Disposal of old electrical and electronic equipment (applicable in the European Union and other European countries with separate collection systems).

This symbol on the product or packaging indicates that this product may not be treated as household waste. This product must be disposed of properly.

2.2 Safety measures in the event of failure

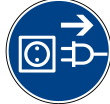

Turn off the "Cleanox" immediately and pull out the mains plug.



Secure and mark the "Cleanox" to ensure that it is not switched on again.

- After any repairs, ensure that the "Cleanox" is fully functional.
- Inspect cables for damage.
- Check the functioning of all safety devices.



If you get electrolyte fluid in your eyes, rinse your eyes immediately with plenty of water.



- See an eye specialist immediately.



Secure hot workpieces against unauthorized access.

2.2.1 Safety-relevant environmental conditions



- **The use of the "Cleanox" is:**
 - Restricted to closed industrial and commercial areas.
 -  Expressly prohibited in fire endangered and potentially explosive environments.
 - Expressly prohibited in humid environments.
- Cover stone and concrete floors well.
 - Acids react with alkaline floor coverings such as:
 - granite
 - marble
 - lime sandstone
 - stoneware
 - tiles
 - screed
 - ...
- Wash electrolyte splashes or stains off immediately with plenty of water and / or Neutralyt.
- **The "Cleanox" may:**
 - Only be operated in well ventilated areas.
-  Chlorinated solvents must be removed from the work area.

-  When operating the "Cleanox", harmful vapours can be caused through chemical reactions.
 - For details, please refer to our SDS's for the respective electrolytes.



Safety information

The operator is obliged to ensure adequate ventilation of the work area
The operator must ensure that the corresponding vapours are removed from the work area with a suitable extraction system.

2.3 Potential sources of danger and protective measures

2.3.1 Potential sources of danger



Improper use of the "Cleanox" and its components.
Placing the cleaning electrode or handle on the workpiece or work surface in such a way that the electrode or the felt / carbon fibre brush is in contact with the metal surface. In this case, current is still flowing.



Incorrect connection of the components can lead to stray currents destroying the electrical protective conductor.

- Defective live cables.
- Damaged or defective switching elements.
- Defective connectors.
- Non-existent or damaged Teflon insulation.
- Incorrect work environment.



Not using protective clothing.



The carbon fibre brush or the electrode as well as the workpiece can reach a temperature of approx. 200°C.



Improper handling of chemicals.

- Electrolyte splashes may cause eye burns.
- Spilled electrolyte fluid can cause stains on stone floors or other surfaces.



Electromagnetic fields can potentially affect cardiac pacemakers.

2.3.2 Protection measures



Repairs to electrical parts of the "Cleanox" or electric cables may only be carried out by qualified electricians.

- Let a qualified electrician check the "Cleanox" immediately after a short circuit or malfunction.
- Only use the "Cleanox" and accessories as intended.
- Only operate the "Cleanox" in the defined work area.



Avoid stray currents.

- Connect the earth wire directly to the workpiece or to the retainer intended for the workpiece.
- Lay the cleaning electrode or handle down on the workpiece or work surface in such a way that the electrode or the felt / carbon fibre brush has no contact with the metal surface. Otherwise, current will continue to flow, which can cause damage or danger.



In the event of an accident, immediately disconnect the "Cleanox" from the mains. Always pull out the plug when carrying out maintenance work.



Only operate the "Cleanox" wearing appropriate, personal, acid-proof protective equipment [protective gloves, apron and goggles].



Always switch the "Cleanox" off before changing the processing tools (brushes, felts...).



Secure hot objects against unintentional contact.



Never eat or drink at your workplace! It is prohibited!



After working with electrolytes, always wash your hands thoroughly with soap and water.

- Wash spilled electrolyte fluid off immediately with plenty of water.



Please observe the detailed instructions in our EC safety data sheet for these electrolytes.

- Store the "Cleanox", accessories or chemicals out of reach of children.



Persons with cardiac pacemakers may:

- Not work with the "Cleanox"
- Not stay in the immediate vicinity of the "Cleanox"!

2.3.3 Before starting work, check



- All current-carrying cables and wires for damage to the insulation.
- All electrified wires and cables for breaks and kinking of the strands inside the insulation.
- All plugs and connectors for damage such as loose solder joints.
- All switches for damage, e.g. chipped housing parts.
- The workpiece clamp for any external damage.
- Whether all Teflon insulations are present and undamaged.
- Please make sure that you do not pull or route any electrical cables across sharp edges.
- Your workplace must be freely accessible
- Make sure there are no tripping hazards.

2.4 Potential misuses



- The connection to an incorrect mains voltage can lead to the destruction of the "Cleanox".
- The connection of external components that are not approved by Reuter GmbH, can:
 - Lead to the destruction of the "Cleanox".
 - Put people at risk.
- The use of chemicals that are not approved by Reuter GmbH can:
 - Lead to health problems,
 - Adversely affect the work results.
- Use of an unsuitable electrolyte for a particular application.
Example: the use of cleaning electrolyte for marking/ labelling:
 - Can result in staining or illegible marking / labelling.
- Carryover of marking electrolyte into the cleaning electrolyte
 - Causes dull places or blacking on the workpiece surface.

2.5 Residual risks

Potential risk	Effect	Remedy
Electrolytes get into the hands of children or people who are inexperienced in dealing with chemicals.	Depending on misuse <ul style="list-style-type: none"> - Skin burns - Burns on clothing - Burns on other objects - Severe internal injuries if the chemicals are swallowed 	Store electrolytes and other chemicals so that they are only accessible to authorized persons.
Appliance is used by unauthorized persons (curiosity, play)	<ul style="list-style-type: none"> - Burning of the skin if the electrode or the workpiece gets too hot - Inhalation of fumes with corresponding health damage 	Ensure that the appliance can only be operated by authorized persons. Secure the appliance after use to prevent improper use.

Table 1 Residual risks

3 Demands on personnel and operators

3.1 Users



- The following knowledge is required:
 - Instruction on operating the "Cleanox".
 - Instruction on handling the components.
 - Safety instruction concerning the dangers associated with handling electrical appliances.
 - Safety instruction concerning the dangers associated with handling chemicals.
- The following activities may be carried out:
 - Operating the "Cleanox".
 - Selecting and using electrolytes for relevant applications.
 - Changing the cleaning and signing tools and the wear parts.
 - Switching the "Cleanox" on and off.
 - Easy troubleshooting after instruction has been given.

This knowledge can be conveyed by either REUTER GmbH & Co. KG or other authorized persons or institutions.

3.2 Operator



- The operator must instruct staff regularly in accordance with legal requirements.
- Untrained personnel or unauthorized persons may not use the "Cleanox".

4 Warranty and liability

Warranty and liability claims for injury and damage to property are excluded if they result from one or more of the following causes:



- **Improper use**
 - Of the "Cleanox".
 - Of components belonging to the "Cleanox".
 - Of chemicals related to the electrochemical processing appliance.
 - Use of unsuitable chemicals.
- **Failure to comply with the**
 - Work and safety instructions.
 - Operating instructions for the "Cleanox" and the components.
- **Improper**
 - Commissioning of the "Cleanox".
 - Commissioning of the "Cleanox" with improperly installed protective devices.
 - Operation of the "Cleanox".
 - Maintenance of the "Cleanox".
 - Repairs carried out on the "Cleanox".
 - Repairs carried out by unqualified personnel.
- **Use**
 - Of the "Cleanox" in private homes and offices.
 - Of the "Cleanox" in fire endangered and potentially explosive environments.
 - Of the "Cleanox" in damp environments.
 - Unauthorised modifications to the "Cleanox"
- **Failure to comply with**
 - The specified maintenance intervals



Note

No claims whatsoever can be made against REUTER GmbH & Co. KG for damage and malfunctioning that arises from operating the "Cleanox" with components and chemicals from other manufacturers.

Unless there is expert proof that the damage was clearly caused by negligent construction or manufacture by REUTER GmbH & Co. KG, and that this was foreseeable at the time of construction.

4.1 Material defects



- The purchaser must inform the supplier of defects without undue delay, within 14 days, in writing.
- If no limitation period for claims has been agreed upon by the supplier and the consumer, the statutory provisions apply.
- When submitting a material defects claim, please include a certificate which shows clearly that the limitation period has not been exceeded.

5 Technical terms

Distilled water

Distilled water contains no minerals and is therefore very "soft". It is obtained by distillation.

Demineralised water

Demineralised water is obtained by filtration. It contains hardly any minerals and is therefore also very "soft".

Electrolyte

Electrolytes are electrically conductive chemicals that are used in various compositions and concentrations for cleaning, polishing and marking.

- MARKING electrolyte is used for labelling.
- Cleaning electrolyte (Cleaner, Super Cleaner, Polisher) is used for cleaning and polishing.

Felts

Felts are absorbent fabrics that are soaked with electrolyte and used for:

- Marking
- Cleaning
- Polishing

Carbon electrode

Carbon electrodes have a rigid carbon body which serves to secure the marking and cleaning felts and transmit electricity.

Carbon fibre brush

Carbon fibre brushes have up to 1.5 million individual carbon fibres. During the cleaning process the current is distributed over the individual fibres. A small arc is formed on every fibre which comes into contact with the workpiece surface (~ 3 - 7 µm in size).

Passivation

Passivation is the inactivation of oxidation processes on the workpiece surface through chemical treatment.

Marking/Labeling

Marking / labelling is a targeted oxidation process, which takes place in the metal surface and not a superficial application of colour particles. Therefore, permanent and forgery-proof! During marking, information is transferred permanently from a template onto the surface of the workpiece by means of a marking electrolyte and electrical current. All electrically conductive metal surfaces can be labelled using the appropriate electrolyte.

Marking templates

Marking templates contain the information that is transferred by means of the marking tool, marking electrolyte and electrical current onto the surface of the workpiece.

Marking stamp

The combination of the carbon electrode handle and the marking felt attached to it is referred to as a marking stamp.

Water hardness

The mineral content of the water determines the degree of hardness. The higher the concentration of certain minerals in the water, the higher the degree of hardness. The hardness grade is measured in "degrees of German hardness" [° dH, deutscher Härte].

6 Delivery, in-house transport, unpacking



The complete appliance set is delivered in a sturdy Euro plastic box. This box is secured with a lead seal in our factory before shipment. The lid can only be opened by destroying and removing the lead seal. In addition, the lid latches are secured on both sides with cable ties to prevent accidental opening.

Safety information

All necessary activities concerning delivery, transportation and storage must be strictly carried out with the utmost care and comply with all safety rules and regulations.

Non-compliance with the safety rules and regulations can lead to serious cuts, bruising and fractures.

6.1 Delivery

- The appliance set is delivered by a carrier or parcel service in orange Euro plastic boxes on pallets.

6.2 Unloading



- Only use lifting equipment and a means of transport that is approved for the corresponding load to unload the equipment supplied.
- All lifting equipment and accessories must be suitable for the intended purpose and comply with current safety standards.

6.3 In-house transport



- For in-house transportation, you must use lifting equipment and a means of transport that is suitable for the intended purpose and complies with current safety standards.

6.4 Unpacking

- Remove the protective film, if present.
- Remove the strapping with which the load is secured to the pallet.
- Cut through the strapping with wire cutters.
- Lift the Euro plastic box(es) carefully from the pallet.
- To do this, only use suitable lifting equipment with safe sling attachment aids.
- Open the Euro plastic box carefully.



Safety information

The strapping is under high mechanical tension. Do not stand in the "trajectory" of the two strapping parts. Never hold the strapping whilst cutting.

- This could result in cuts.
- Wear appropriate protective clothing.

6.4.1 Opening the Euro plastic box



- First cut through the lead seal with metal shears
- Remove the lead seal carefully.
- Remove the cable ties on the right and left of the lid latches.
- Unlock the lid latches
- To do this, slide the lid latches to the left or the right.
- Open the transport box.
- Check the delivery against the delivery note for completeness.
- Report missing, damaged or undelivered goods immediately.



Safety information

Cutting the lead seal with the metal shears can cause sharp edges. Wear gloves when removing the lead seal, to avoid cuts!



Tip

You can find the following information on and under the lid of the Euro plastic box:

- Safe handling of chemicals
- Information on the weight of the Euro plastic box including contents.
- Safety data sheets
- Brief instructions
- Accessories catalogue

Please take note of this information!

7 Scope of delivery of the "Cleanox" appliance set



- Check that the appliance set is complete when unpacking the delivery.
- Report missing or damaged parts immediately.

7.1 Delivery list, "Cleanox" cleaning set

Description		Quantity	Order No.	Illustration
"Cleanox" cleaning set	✓	1	EP-01-0.	









Cleaning set items		Quantity	Order No.	Illustration
Cleanox 2.0 or Cleanox 4.0 or Cleanox 4.2	✓	1	EP-01-020 or EP-01-040 or EP-01-042	 Example Cleanox 4.2
Teflon handle with 4m cable 10mm ²	✓	1	EP-07-600	
Earthing cable, 4m, with 200A clamp	✓	1	EP-07-605	
Carbon fibre brush XL incl. 2 pins (assembly aid)	✓	1	EP-02-912	
Cleaner and polisher electrolyte	✓	0.5kg each		
Wide-mouth container	✓	500 ml	EP-07-100	
Spray bottle for water	✓	500 ml	EP-07-002	
Euro plastic box	✓	1	EP-07-017	

Table 2 Delivery list

8 Storage requirements



For safe and careful storage of the "Cleanox" and accessories, please observe the following measures:

- Keep the appliance set in the closed transport box.
- Protect against moisture and dust.
- Ambient temperature 5°C to 40°C.
- Do not store outdoors.
- Protect against exposure to acids and alkalis.
- Store only in the normal standing position.
- Do not expose to ionizing or non-ionizing radiation.
- The appliance set must not be exposed to vibration, shock or continuous shock.



Safety information

Keep chemicals out of reach of children!
Keep them under lock and key!

9 Installation conditions

9.1 Safety



The "Cleanox" and accessories may only be installed and operated in a location which fulfils the installation requirements. All electrical connections must comply with current safety regulations and standards.

10 Decommissioning / storage

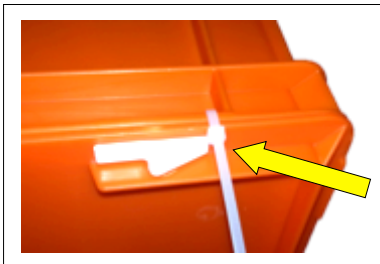

- Decommissioning
- Switch off the appliance.
- Wash the carbon fibre brush and handle thoroughly with water.
- Wipe the cable with a damp cloth.
- Clean the appliance and accessories thoroughly. Maintenance should be carried out by a qualified technician.
- See detailed instructions on how to clean the appliance and accessories in chapter 21.
- Dry all items
- Close the electrolyte container carefully so that no electrolyte can leak out. Pack the appliance and accessories into the transport box.
- Close the transport box and secure it with a cable tie against unintentional opening

11 Storage

- Store the closed transport box in a dry and frost free place.
- Make sure that the closed transport box cannot fall into the hands of children or other unauthorised persons.

12 Appliance technology

The "Cleanox" is a compact electro-chemical high-current brush weld cleaner. It was developed for commercial use in skilled trades and industry. Simple operation makes the device ideal for building sites and pipe installations.

- It is suitable for:
 - Cleaning and polishing TIG and MAG welds.
 - The performance levels also enable the Cleanox to perform cleaning and polishing at a less intensive level.
- In combination with our marking set, the appliance is also suitable for light and dark marking.
 - Dark marking can be used to apply dark labelling - e.g. batch numbers or type plates.
 - Light marking is used on aluminium materials (these cannot be dark marked) and is the preferred method for high-gloss surfaces.
- No toxic hydrofluoric, sulphuric or nitric acids, common in conventional pickling processes, are used.
- These electrochemical processing appliances work with low DC and AC voltages, which are not dangerous for humans.



Note

Our cleaning and polishing electrolytes are guaranteed non-toxic!

Type	Cleaning and polishing with	Cleaning with	marking with optional marking set		Caution! The "Cleanox" is only designed for cleaning and polishing welds with a carbon fibre brush.
			Light	Dark	
"Cleanox"	Carbon fibre brush	Carbon electrode			
	M, XL	Never use!			
	✓		✓	✓	

12.1 Applications





	Cleaning with the carbon fibre brush	Polishing with the carbon fibre brush	Cleaning + polishing with the carbon electrode	Marking	
Tools	M, XL 	M, XL 		dark 	light 
Cleanox 4.2 Power output:	●	●	Never use	●	●
Cleanox 4.0 Power output:	●	●		●	●
Cleanox 2.0 Power output:	●	--		●	--
● Fully operable ○ Conditionally operable -- Not operable					

Table 3 Application area

13 Controls and operating elements on the front pane I



13.1 Automatic circuit breaker (overload FUSE)

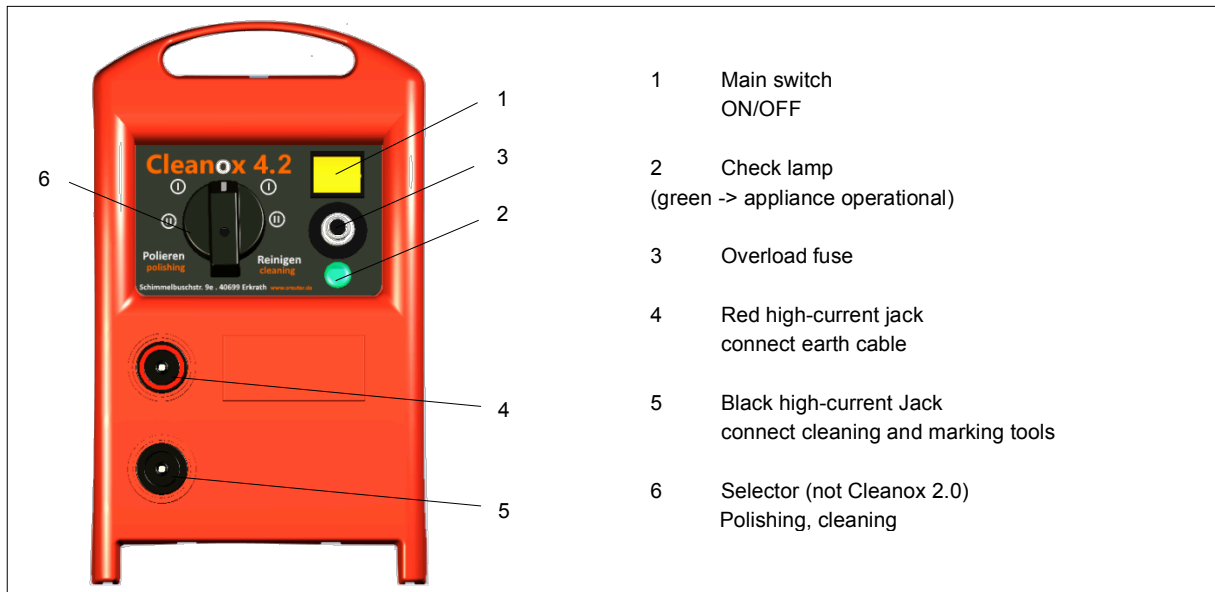

The "Cleanox" is equipped with an automatic circuit breaker.

- In the event of overload or an electrical short circuit, the circuit breaker interrupts the circuit.

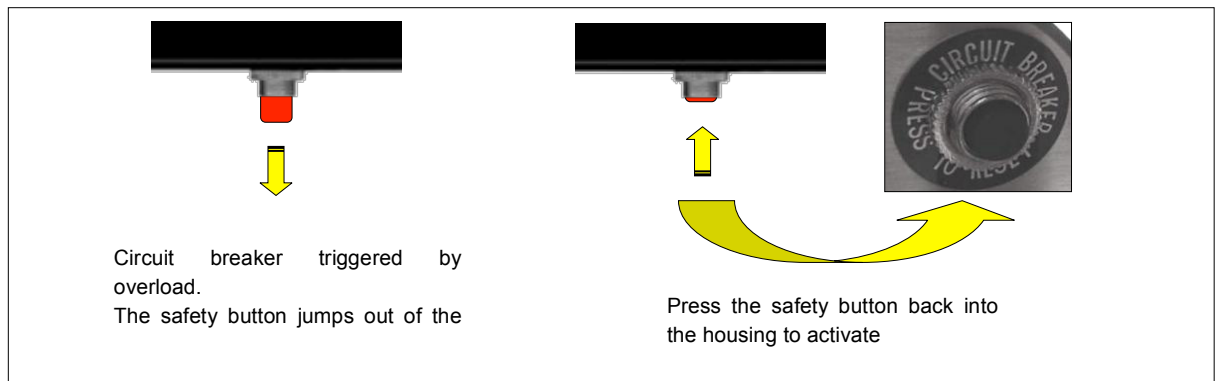

Safety information

Wait a moment until the circuit breaker has cooled down.

Before activating the circuit breaker button:

- The appliance must be switched off or the selector turned to position "0".
- There must be no contact between the brush and the workpiece or earth.

If the circuit breaker is triggered again, check the way you are working!

- Dip the brush into the wide-mouth container more frequently and for a longer time!
- Do not press the brush too hard against the workpiece!



13.2 High current jacks

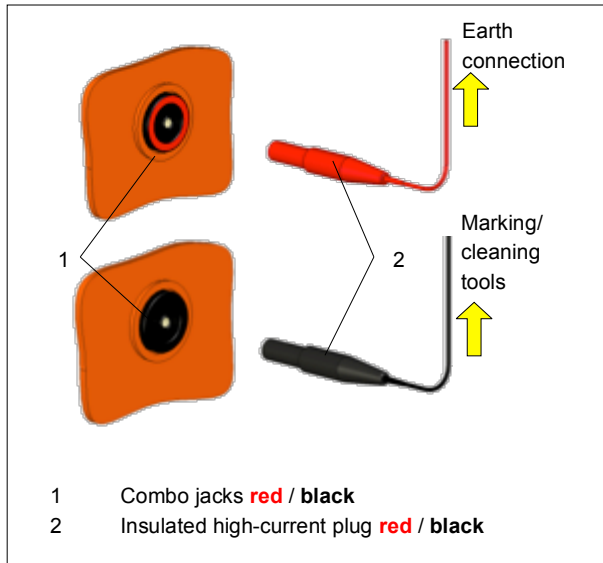

The "Cleanox" is equipped with combo jacks for safely transmitting the cleaning current.

- High-current jack "**red**"
 - **Always** use to connect the high-current plug with the "**red**" 10mm² cable.
 - **Always** use to connect the earth clip
- High-current jack "**black**"
 - **Always** use to connect the high-current plug with the "**black**" 10mm² cable
 - Always use to connect the cleaning and marking tools (Teflon handle, carbon fibre brush).



Note

The 10mm² high-current plugs lock automatically when inserted into the high-current jacks and can only be released by lightly pushing inwards again.



13.3 Elements on the back panel

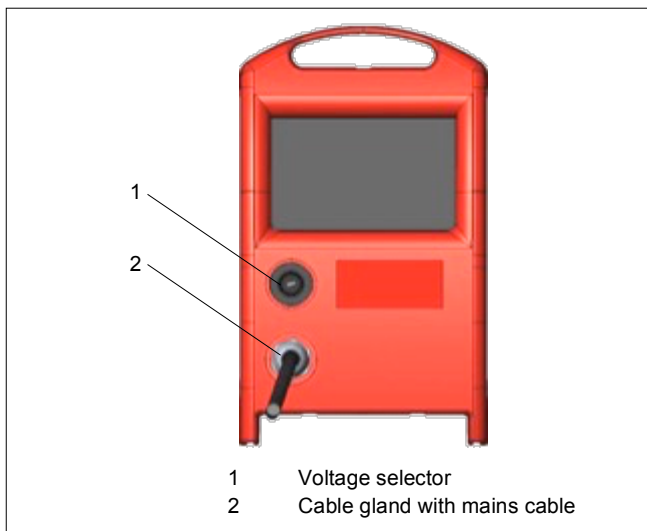

- Voltage selector (**only Cleanox 4.2**)
 - Mains voltage setting to 230V or 115V.
 - The appliance is factory preset to 230V



Never operate the appliance with 230V if the voltage selector is set to 115V.

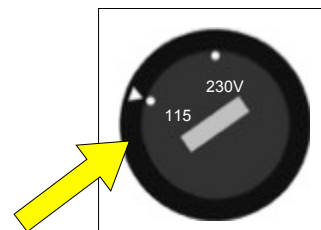

Safety information

The appliance must be disconnected from the mains before the voltage selector is used.

- Mains plug unplugged
- Mains switch to "0".

14 Accessories

14.1 Teflon handle with cable and plug

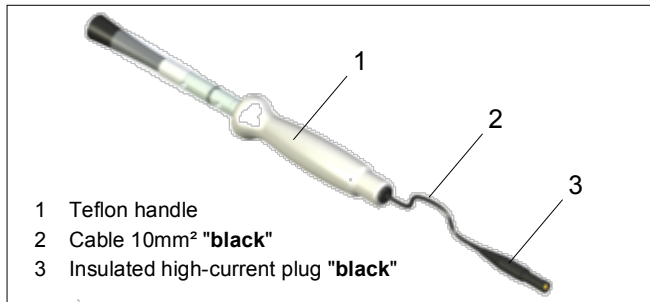

- The Teflon handle (1) is fixed to the **black** 10mm² cable (2) and the **black** high-current plug (3).
 - **Always** insert the **black** high-current plug (3) into the **black** high-current jack.
- Tool connections are always **black**.

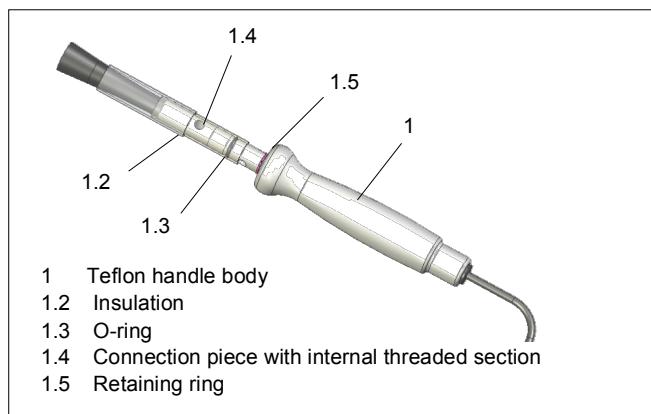

The Teflon handle consists of the following components:

- Teflon handle body (1)
 - Electrical insulation
 - Thermal insulation
- Electrical insulation (1.2)
- O-ring(1.3)
 - Prevents electrolyte passing into the interior of the brush.
- Connection piece with threaded section (1.4)
 - Brush fixture
 - Power transmission

14.2 Earth clip with cable and plug

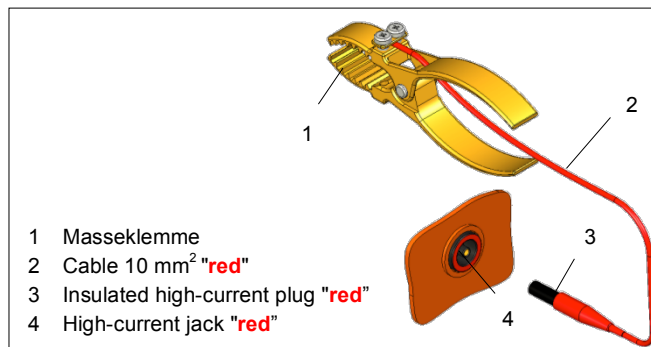

- The earth clip (1) is fixed to the **red** 10mm² cable (2) and the **red** high-current plug (3).
 - **Always** insert the **red** high-current plug (3) into the **red** high-current jack (4).
- Earth connections are always **"red"**.

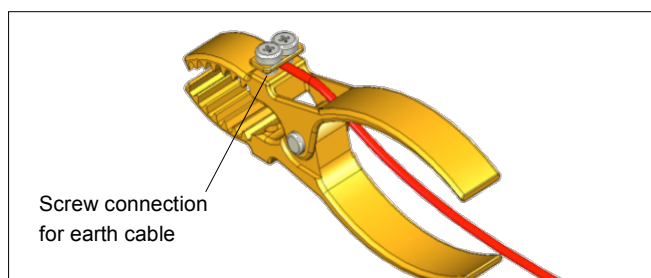

- The earth clip (cast brass clip) establishes the electrical contact between the workpiece and the electrochemical cleaning appliance.

14.3 Carbon fibre brush XL

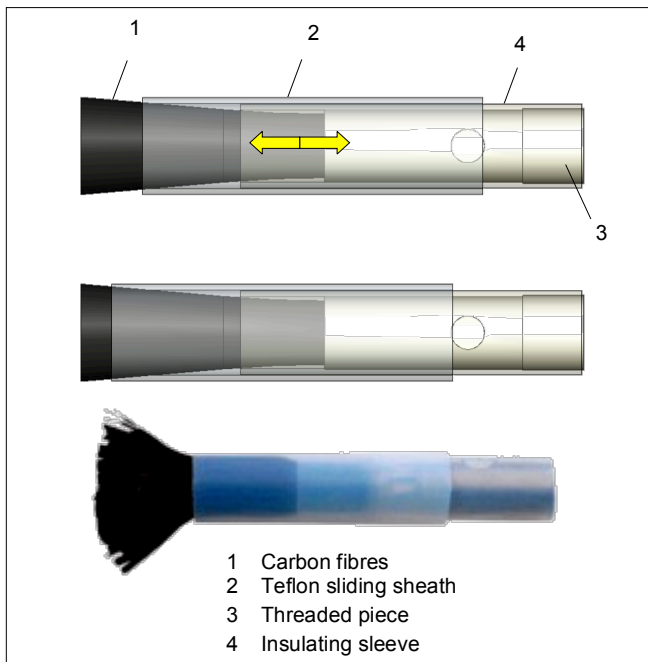

Use the carbon fibre brush supplied, type XL, for cleaning welds.

The carbon fibre brush comprises the following components:

- ~ 1.5 million individual carbon fibres (1)
 - The light arcs, important for the cleaning process, form on the ends of these fibres
- Connection piece with internal thread (3)
 - Fixing the brush on Teflon handle and power transmission: Handle <--> carbon fibre
- Teflon sliding sheath (2)
 - Wear compensation
 - The combustion of the carbon fibres is compensated for by sliding

See our accessories catalogue for a variety of special brushes for different applications, available in addition to the carbon fibre brush supplied.



Note

New brushes must first be worked in before they develop their full cleaning effect.

14.4 Assembly carbon fibre brush XL / Teflon handle

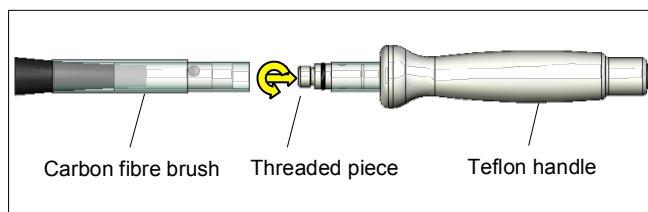

Use the carbon fibre brush XL for cleaning welds.

- Screw the carbon fibre brush onto the white Teflon handle.
- Tighten the brush firmly.
- Note the tip for tightening and loosening the screw joint.



Safety information:

Make sure that the carbon fibre brush is firmly attached. A loose screw joint can burn and damage the thread.

- The Teflon insulation must be present both on the handle and the brush, as the high currents could otherwise lead to shunts via the workpiece.

Indication of possible malfunction

No power or only insufficient power reaches the brush at the front. However, the green LED on the front panel lights up.

- Cause: With 99% probability, insufficient contact between the threaded piece and the brush.

Remedy:

Check the thread for:

- Oxidation, damage, loose fit.
- Clean the thread with a wire brush.
- Apply some copper paste or Molykote grease to the thread.
- Screw threaded piece and brush together tightly.
- To do this, use the mounting pins supplied.

Tip for tightening and loosening tight screw joints:

- Insert the two pins supplied through the cross-holes in the lower part of the handle and the brush.
- You can then apply greater force for tightening or loosening.

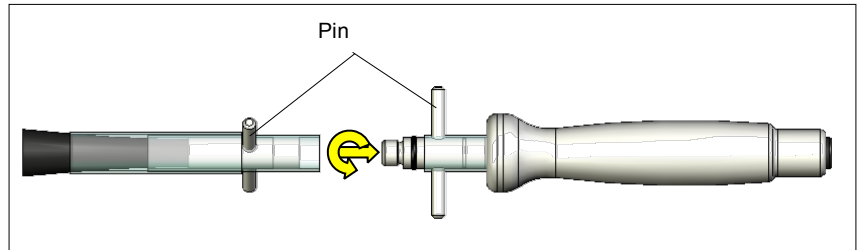
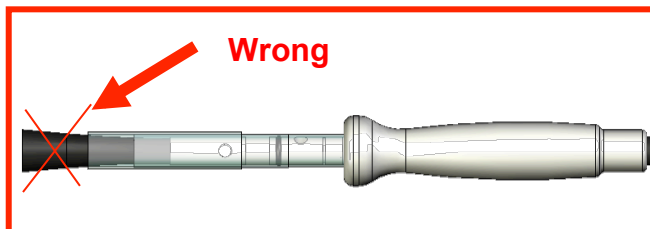
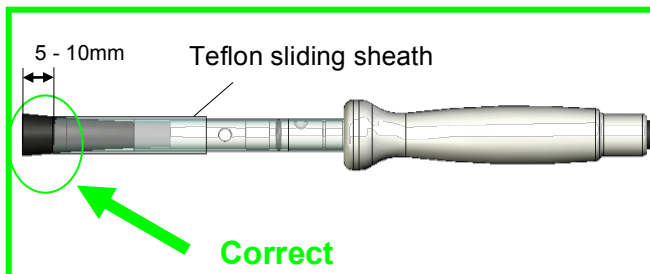
14.4.1 Adjusting the Teflon sliding sheath

- During the cleaning process, the carbon fibre tips of the carbon fibre brush wear out.
- By means of the Teflon sliding sheath, you compensate for the wear on the carbon fibres.
 - Adjust the Teflon sliding sheath on the carbon fibre brush so that the carbon fibre tips protrude by approx. **5-10 mm**.
 - The many small arcs between the carbon fibre ends and the workpiece can only form if this is correct! This guarantees an optimum cleaning effect.

14.5 Electrolyte

Note

We have a wide range of suitable electrolytes available for you, suitable for the different applications and materials. Please follow our operating instruction carefully when using electrolytes. Observe all safety regulations. For questions regarding the application of our electrolytes, please contact REUTER directly. We are happy to advise you.

14.5.1 Transferring into the wide-mouth container

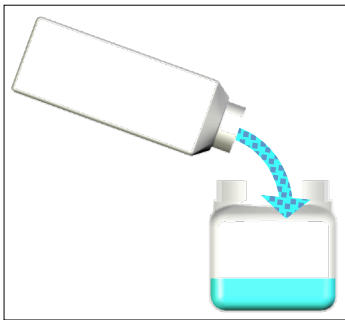

- Use the wide-mouth container supplied!
- Unscrew the cap of the container
 - Carefully make 2 holes in the aluminium seal.
- Fill the wide-mouth container up to the first lower mark with electrolyte.
 - This corresponds to a fill level of 2cm.
- Never fill the wide-mouth container too full.
 - The electrode handle remains dry and electrolyte cannot get onto your hands.

Safety information

The wide-mouth container can tip over due to the weight of the handle or accidental tension on the cable.

Electrolyte may leak out.

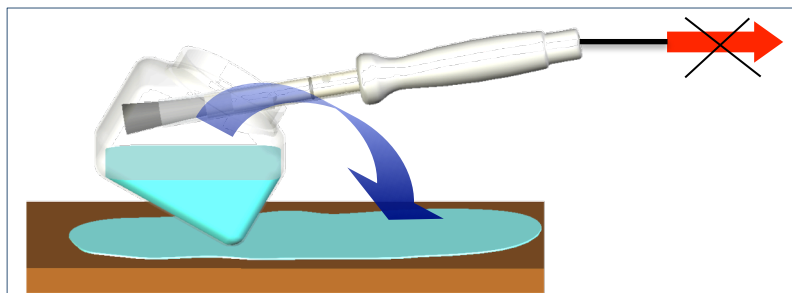

Tip

We recommend the use of our safety holder for the wide-mouth container.



- Item No.: EP-07-102

14.5.2 Information concerning non-toxicity



- We only use non-toxic mineral acids in different concentrations as cleaning electrolytes.
- Our electrolytes are also used as acids and preservatives in food, in low concentrations - the acidifier E338 in Cola, for example.



**We hereby confirm that our cleaning electrolytes
CLEANER / SUPERCLEANER / POLISHER
are non-toxic!**

14.5.3 Information concerning the scope of delivery

- We provide cleaning and polishing electrolytes in the following sizes:
 - 1.5 litre container, 5 litre bottle with handle, 30 litre canister.
- For production reasons the containers are never completely filled.
- The fill level depends on the specific gravity of the electrolyte.
- POLISHER is more concentrated and its density is almost twice as high as that of CLEANER electrolyte. This explains the different container fill levels for the same weight of electrolyte.
- Our containers are provided with safety caps and are therefore leak-proof until opened.
- Our 1.5 litre container, 5 litre bottle with handle, 30 litre canister are approved according to the German Federal Institute for Materials Research and Testing (BAM) and the UN as packaging for dangerous goods.

15 Commissioning

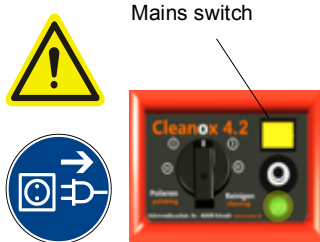

Safety information

The "Cleanox" must be switched off when connecting the cable and when changing handles, brushes, carbon electrodes or felts.

- Selector to **0**
- Mains switch off.

The "Cleanox" is equipped for single-phase connection to 230V / 50Hz earthed sockets and provided with a standard safety plug.

16 Connection

16.1 Mains connection

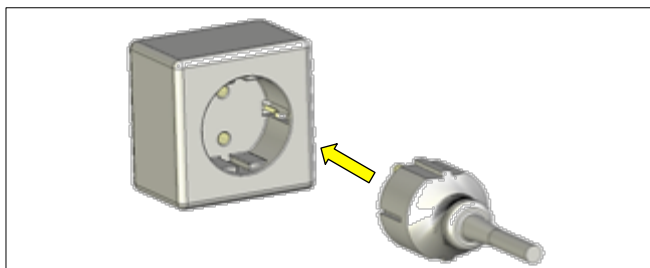

- Connect the mains plug of the "Cleanox" with an appropriate 230V mains socket.
 - Observe the safety information.



Safety information

Pay attention to the correct setting of the voltage selector (chapter 12.3 / only Cleanox 4.2).

- 230V - 230V
- 115V - 115V

16.2 Connecting the Teflon handle with the carbon fibre brush

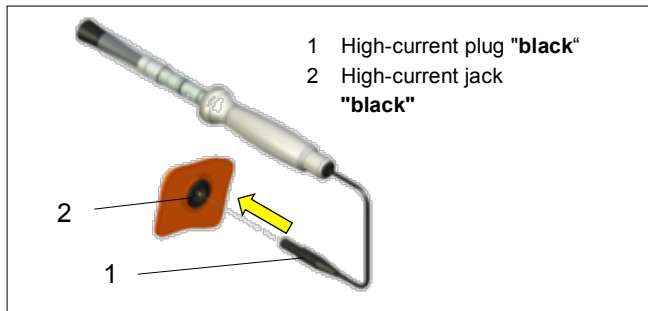

- Assemble the (carbon fibre brush, chapter 13.1 - 13.5)
- Connect the **black** high-current plug (1) with the **black** high-current jack (2) on the appliance.

16.3 Earth clip connection

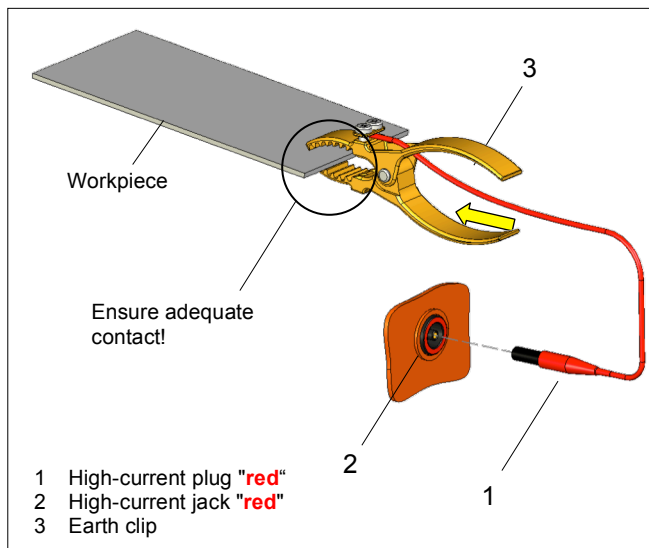

- The earth clip (3) establishes the electrical contact between the workpiece and the electrochemical cleaning appliance.
- Ensure good electrical contact between the earth clip (3) and the workpiece.
- Clean the contact point if necessary.
- Connect the **red** high-current plug (1) to the **red** high-current jack (2) on the appliance.



Safety information

Very high currents flow during cleaning.

- Connect the earth clip directly to the workpiece to prevent shunts.

16.3.1 Lock / release high-current plug



Note

The high-current plugs lock automatically when inserted into the high-current jacks and can only be released by pressing inwards again!

Ensure that the connections are correct.

- **Red** high-current plug in **red** high-current jack.
- **Black** high-current plug in **black** high-current jack.
-

The following procedure applies for **red** and **black** high-current plugs.

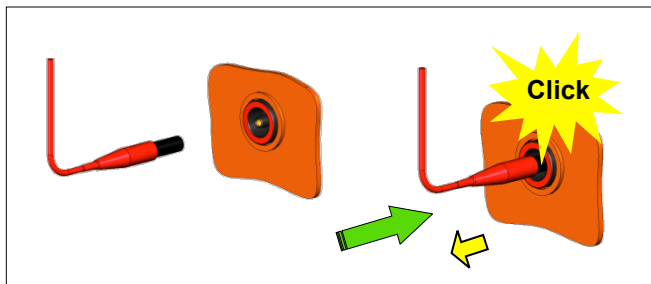

- Push the high-current plug into the high-current jack until you feel a distinct clicking.
- Check the correct fitting of the high-current plug by pulling it gently.
 - The plug should not pull out.

16.3.2 Releasing the high-current plug

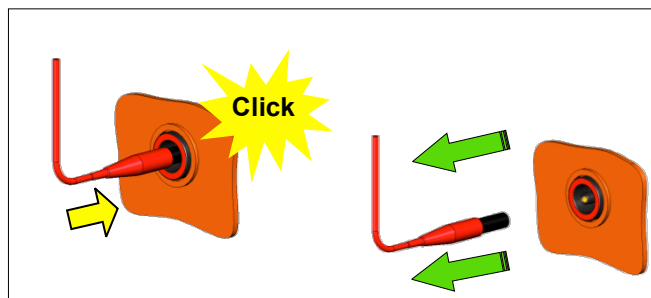

- To release, press the high-current plug lightly into the high-current jack until you feel resistance (slight click).
 - The lock is released.
 - Now pull the high-current plug out of the high-current jack.

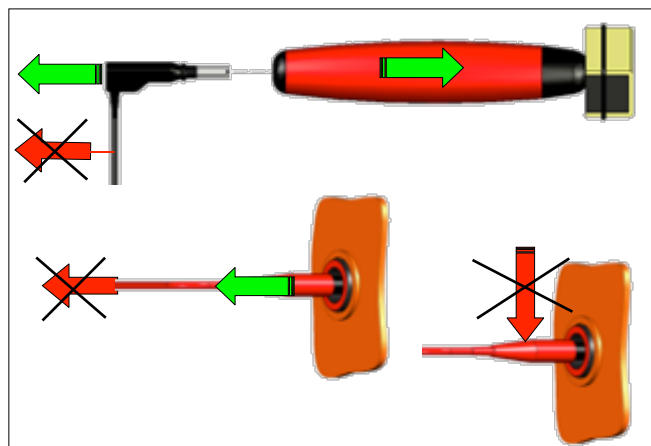

Safety information

- Never pull the plug out of the jack by the cable!
 - This can damage the cables.
- Never put weight on the plug transversely.
 - Jacks can easily break at the edges.

17 Working with the "Cleanox"

- The amounts of electrolyte used are so low that, on their own, they have no cleaning or marking effects.
- The desired effects are only achieved when electrolysis, caused by the flow of current, and the temperature increase on the workpiece surface set the chemical processes in motion.
- This depends on a precise matching of electrolyte, voltage types, currents and the correct choice of material for the electrodes.
- Our many years of experience in welding and handling pickling chemicals has enabled us to develop this highly effective and environmentally friendly electrochemical high-current cleaning process with carbon brushes.
- The unsurpassed cleaning effect is mainly achieved by the strong high-current source and the millions of small arcs at the ends of the carbon fibres.

- The electrolytes can therefore be produced from non-toxic mineral acids in very low concentrations, and nevertheless achieve unmatched cleaning performance.

18 Cleaning with the carbon fibre brush

18.1 Preparation





- Teflon handle with carbon fibre brush XL.
- Earth clip
- Cleaning electrolyte.



Safety information

Have all components been correctly installed and connected?

18.2 Workflow, cleaning with carbon fibre brush

	Workflow - cleaning	Comment
1		<ul style="list-style-type: none"> ● Switch on the appliance. <ul style="list-style-type: none"> ➢ The mains switch lights up.
		<ul style="list-style-type: none"> ➢ The green control lamp only lights up when the selector is no longer set to "0".
		<ul style="list-style-type: none"> ➢ The green control lamp lights up as soon as the mains switch is turned on.
2		<p>Safety information</p> <ul style="list-style-type: none"> ➢ Never switch the appliance ON/OFF with the mains switch repeatedly, in quick succession. ➢ These appliances are equipped with an inrush current limiting device, which prevents the circuit-breaker triggering too quickly. ➢ Switching on/off in quick succession may damage the electronics in the appliance. Wait at least 30 seconds after switching off before switching the appliance on again.

<p>3</p>		<ul style="list-style-type: none"> ● Set the selector to level "I" cleaning <ul style="list-style-type: none"> ➤ LED lights up
		<ul style="list-style-type: none"> ➤ LED lights up
<p>4</p>		<ul style="list-style-type: none"> ● Dip the carbon fibre brush into the wide-mouth container. ● Take the carbon fibre brush out again and let excess electrolyte drip off.

<p>5</p>		<ul style="list-style-type: none"> ● Position the brush vertically on the workpiece. ● Now stroke lightly over the welding seam with the brush. <ul style="list-style-type: none"> ➢ Move the carbon brush as you would when painting with a normal brush. ● Never press too hard on the carbon fibre brush <ul style="list-style-type: none"> ➢ Just circle lightly, with a circle diameter of 1-2 cm, and glide very slowly over the surface of the workpiece. ● The maximum cleaning effect is achieved when the carbon fibres are perpendicular to the workpiece surface. <ul style="list-style-type: none"> ➢ Only in this way do the arcs, which are decisive for the cleaning process, form at the tips of the carbon fibres. ● Depending on the quality of the weld, you will need to brush over it several times in order to achieve the desired cleaning effect. <ul style="list-style-type: none"> ➢ The darker the tarnishing of the welds, the longer the cleaning phase. ➢ You can increase the cleaning effect on heavily oxidized welds by using our SUPERCLEANERS or POLISHERS.
<p>6</p>		<ul style="list-style-type: none"> ● Dip the carbon fibre brush into the wide-mouth container at regular intervals. <ul style="list-style-type: none"> ➢ Move the carbon fibre brush back and forth, 2-3 times, in the wide-mouth container. ➢ Dissolved oxides are removed ➢ The carbon fibres can absorb fresh electrolyte. ➢ You achieve maximum cooling of the electrode and increase its service life.
<p>7</p>		<ul style="list-style-type: none"> ● After cleaning, spray the surface off immediately with water. <ul style="list-style-type: none"> ➢ Use the spray bottle supplied ➢ Use demineralised or distilled water. ➢ In this way, you avoid unsightly white edges of lime. ➢ The water hardness must be less than 10° dH. ➢ The suddenly evaporating water entrains the dissolved impurities and electrolyte residues.
<p>8</p>		<ul style="list-style-type: none"> ● Dry the surface. <ul style="list-style-type: none"> ➢ Use paper towels. ➢ In this way, you obtain a stain-free, dry surface.
<p>For further information on improving the cleaning results, see "Tips".</p>		

Table 4 Workflow, cleaning

18.3 Intensive cleaning with carbon fibre brush (only Cleanox 4.2)

18.3.1 Preparation

- As when cleaning with a carbon fibre brush

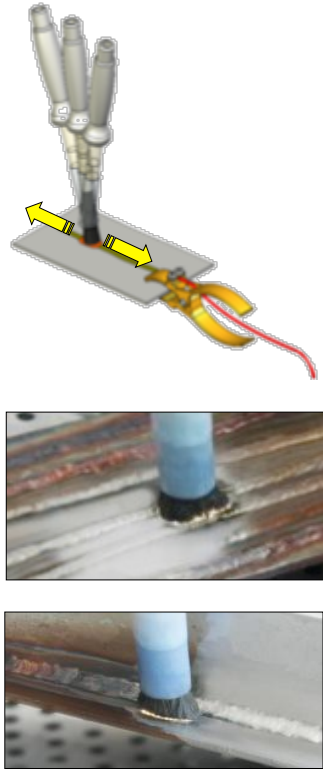
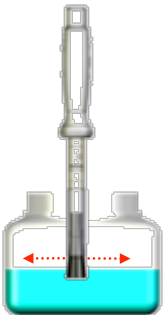
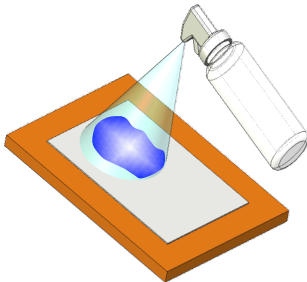
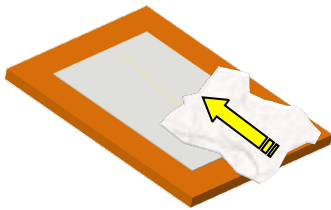
18.3.2 Workflow, strong cleaning







	Workflow, strong cleaning	Comment
1		<ul style="list-style-type: none"> ● Switch on the appliance. <ul style="list-style-type: none"> ➢ The mains switch lights up.
2		<p>Safety information</p> <ul style="list-style-type: none"> ➢ Never switch the appliance ON/OFF with the mains switch repeatedly, in quick succession. ➢ These appliances are equipped with an inrush current limiting device, which prevents the circuit-breaker triggering too quickly. ➢ Switching on/off in quick succession may damage the electronics in the appliance. ➢ Wait at least 30 seconds after switching off before switching the appliance on again.
3		<ul style="list-style-type: none"> ● Set the selector to performance level "II" <ul style="list-style-type: none"> ➢ Strong cleaning ➢ LED lights up
4		<ul style="list-style-type: none"> ● Carry out strong cleaning in the same way as normal cleaning. <ul style="list-style-type: none"> ➢ Only use the strong cleaning level briefly, to remove heavy scaling, then switch back to level "I" immediately. This extends the service life of the brush significantly.
5	  	<p>Safety information</p> <ul style="list-style-type: none"> ● Only apply "strong cleaning" for a short time. <ul style="list-style-type: none"> ➢ Then switch immediately back to operating position "I" and continue to work normally! ● Carbon fibre brushes get very hot. <ul style="list-style-type: none"> ➢ Only grasp the carbon fibre brush and the Teflon sliding sheath wearing gloves. ➢ Or better: let it cool or rinse it with plenty of water. ● Smoke development is stronger when cleaning at performance level "II". <ul style="list-style-type: none"> ➢ For chrome/nickel cleaning, please use the specified air extraction systems.

Table 5 Workflow, - strong cleaning

18.4 Polishing with the carbon fibre brush

Previously cleaned welds can be:



- Highly polished or the brightness can be matched to the surrounding surface.
 - Oxides, silicates and scaling, which could not be completely removed through cleaning, can be removed almost entirely through polishing.
 - However, this results in a slightly shiny surface.

Use our components for polishing stainless steel surfaces and welds only.

18.4.1 Preparation

- Teflon handle with carbon fibre brush XL (4).
- POLISHER electrolyte.
- Earth connection

18.4.2 Workflow, polishing

Workflow, polishing	
2	 <ul style="list-style-type: none"> ● Switch on the appliance. <ul style="list-style-type: none"> ➢ The mains switch lights up.
2	
2	 <p>Safety information</p> <ul style="list-style-type: none"> ➢ Never switch the appliance ON/OFF with the mains switch repeatedly, in quick succession. ➢ These appliances are equipped with an inrush current limiting device, which prevents the circuit-breaker triggering too quickly. ➢ Switching on/off in quick succession may damage the electronics in the appliance. ➢ Wait at least 30 seconds after switching off before switching the appliance on again.

3		<ul style="list-style-type: none"> ● Set the selector to performance level "I" <ul style="list-style-type: none"> ➤ Normal polishing ➤ LED lights up ● Or, in the case of heavy soiling, to performance level "II" <ul style="list-style-type: none"> ➤ Strong polishing ➤ LED lights up
		<ul style="list-style-type: none"> ● Set the selector to performance level "I" <ul style="list-style-type: none"> ➤ Normal polishing ➤ LED lights up
4		<ul style="list-style-type: none"> ● For polishing use our Polisher electrolyte.
5		<ul style="list-style-type: none"> ● The workflow for polishing is the same as for cleaning
6		<p>Note If required, you can seal the surface with our Neutralyt (see catalogue).</p> <ul style="list-style-type: none"> ➤ The surface is then less sensitive to resoiling ➤ E.g. fingerprints. ➤ Prevents subsequent rusting on corrosion-sensitive surfaces
<p>For more information, see the tips for "cleaning" and "polishing".</p>		

Table 6 Workflow, polishing

Tips for improving the cleaning result

- Prolonged cleaning without re-wetting the carbon brush with electrolyte leads to excessive heating of the electrode and the workpiece.
 - This increases the wear on the carbon brush and reduces the service life and cleaning effect!
 - Never clean too long in one place
- After cleaning, dull spots sometimes remain on either side of the weld in the HAZ (heat affected zone). The dull spots are caused by the welding process (chromium depletion).
 - This is process-related and cannot be removed through more intensive cleaning!
 - Switching to "polishing" can neutralise the chromium depletion.
- You can match the gloss level by targeted polishing of the dull spots.
 - After cleaning, spray the surface off immediately with water. The suddenly evaporating water entrains the dissolved impurities and electrolyte residues. In this way, you obtain a stain-free, dry surface.
- A spray bottle is supplied with the appliance set for this purpose.
- It is best to use demineralised water.
 - In this way, you avoid unsightly white edges of lime.
 - The water hardness must be less than 10° dH.
- Dry the surface with paper towels.
- Finish your workpiece, if necessary, with a commercially available stainless steel care product
- This makes the surface less sensitive to soiling, e.g. with fingerprints.



***We recommend using our
“FPR” Finger-Print-Remover!***

***Remove white spots, which sometimes arise
after cleaning the surface, with our SFC
(stainless finishing cleaner)!***

19 Marking / Labelling (optional)



Note

You will need our marking set for marking with the Cleanox.

All electrically conductive metal surfaces can be labelled using the appropriate electrolyte.

A distinction is made between dark and light marking.

- **Dark** marking is a targeted oxidation process, which takes place within the metal surface.
 - No superficial application of colour particles.
 - Therefore, permanent and forgery-proof!
 - Not so ideal for non-ferrous metals.

- **Light** marking or negative marking is also known as "etching".
 - In contrast to dark marking, material is removed from the surface during this process, in places where there are micro-perforations in the templates.
 - Light marking is preferably used on aluminium materials and high-gloss surfaces.
 - Aluminium materials cannot be dark marked
 - Use our Marking electrolytes for light marking, which have been specially designed for the process.

- Prepare the workpiece and the marking stamp in the same way as for dark marking.

- For light marking, proceed in the same way as for dark marking.

- The marking time is longer, however
 - ~ 3 - 5 sec.

- **Pay attention to the position of the selector**

19.1 Marking set in case (optional)







Scope of delivery, marking set		Quantity	Order No.	Illustration
Marking set "Cleanox"	✓	1	EP-02-050	
Parts for marking				
2m connection cable (1.5mm ²) with 4mm safety plug, black	✓	1	EP-07-004-sw	
Complete cleaning handle with 90° carbon electrode, felt and O-ring	✓	1	EP-02-018	
Felt white 40x60x2	✓	5	EP-03-101	
Marking templates	✓	1	Example	
O-rings	✓	5	EP-03-000	
Marking electrolyte	✓	50ml	EP-04-444	

Table 7 Marking set

19.2 Cable 1.5mm² with 4mm safety plug

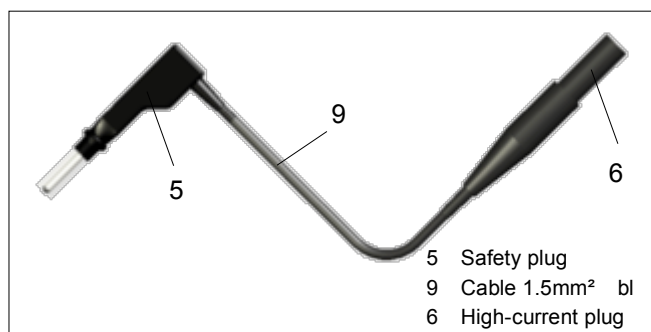

To work with the marking stamp you will need our special connection cable with 1.5mm² cross-section.

- Connections for marking and cleaning tools are always "**black**".

19.3 Marking stamp

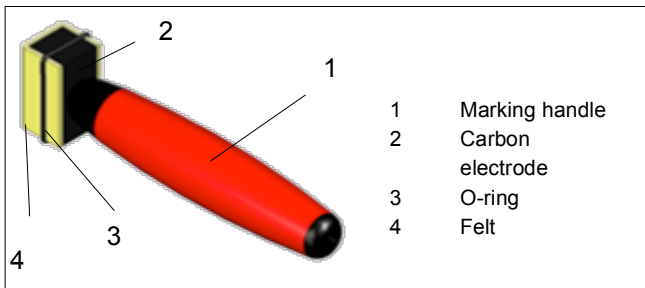

- Use the **red** marking handle (1) with the 90° carbon electrode (2) and white felt (4) for marking.
- The marking handle is delivered completely assembled and ready for immediate use.



From now on, the assembled combination of felt, carbon electrode, O-ring and handle will be referred to as **marking stamp**.

19.4 Connecting the marking stamp

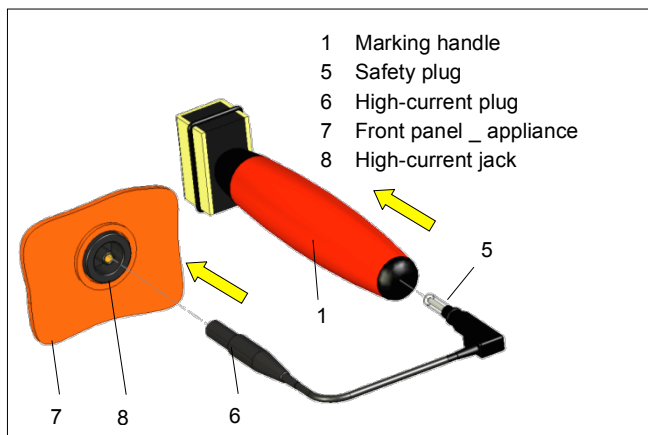

- Insert the **black** safety plug (5) with the transparent, sliding insulating sleeve into the jack in the marking handle (1).
- Insert the **black** 10mm² high-current plug (6) into the **black** high-current jack (8) on the appliance

19.5 Changing the marking felt

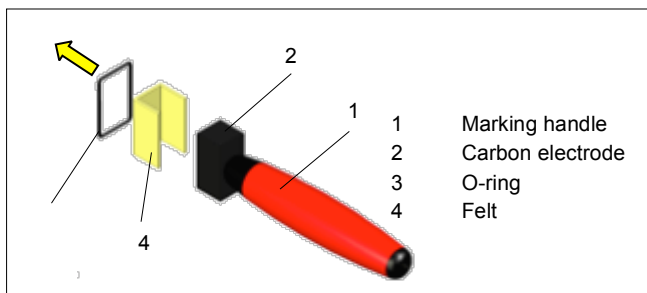

- First remove the O-ring
- Now remove the felt
 - Dispose of the felt properly

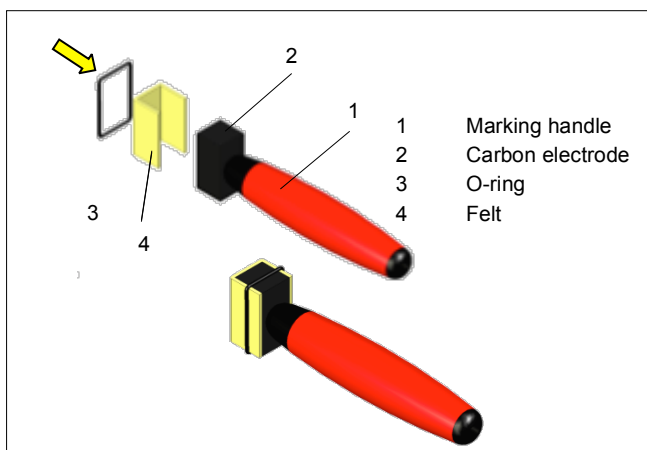

- Use a white marking felt.
 - Fold the felt in half and lay it over the carbon electrode.
 - Secure the felt with the O-ring supplied.

19.6 Templates

19.6.1 Short-term templates

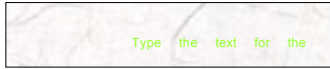

Short-term templates are used to mark / label smaller quantities.

- Create a template with your printer.
- Remove the template.
- Remove the protective paper.
- Marking is carried out using the white cardboard.

19.6.2 Long-term templates

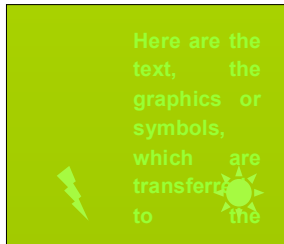

Long term templates suitable for marking/labelling large quantities.

- These templates are produced using a printing method and based on template files.
- The following common file formats can be used for the template files: PDF, JPG, TIF ...

We would be happy to create long-term templates according to your specifications.



- You can choose from different templates dimensions.
- Please contact our distribution and sales staff if we can be of help.





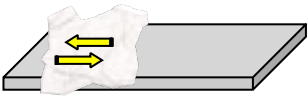
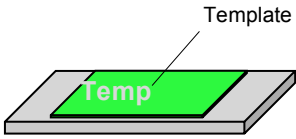

Tip

You can also create short-term templates with a printer, yourself. In our price list you will find the optimal printer and the appropriate template material for every application. For more information concerning printers, see **chapter 25.7**.

19.7 Dark marking

	Workflow - dark marking	Comment
1		<ul style="list-style-type: none"> ● Clean the area of the workpiece to be marked before starting to mark/label it.
2		<ul style="list-style-type: none"> ● Position the template or labelling strip on the workpiece.
3		<p>Tip Before starting work, wet the templates with water or marking electrolyte</p> <ul style="list-style-type: none"> ➤ These then adhere to the workpiece better and do not slip so easily!

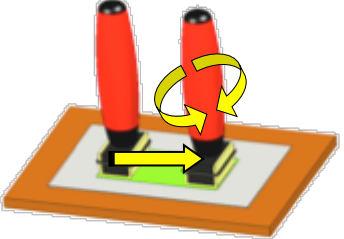
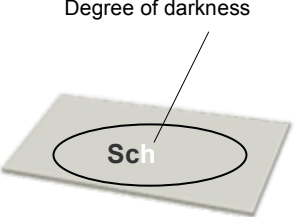
4		<ul style="list-style-type: none"> ● Switch on the appliance. <ul style="list-style-type: none"> ➢ The mains switch lights up.
5		<p>Safety information</p> <ul style="list-style-type: none"> ➢ Never switch the appliance ON/OFF with the mains switch repeatedly, in quick succession. ➢ These appliances are equipped with an inrush current limiting device, which prevents the circuit-breaker triggering too quickly. ➢ Switching on/off in quick succession may damage the electronics in the appliance. ➢ Wait at least 30 seconds after switching off before switching the appliance on again.
6		<ul style="list-style-type: none"> ● Set the selector for dark signing to level "I" <ul style="list-style-type: none"> ➢ Cleaning ➢ LED lights up
7		<ul style="list-style-type: none"> ● Drip some drops of marking electrolyte onto the felt until it is fully wetted.
8		<ul style="list-style-type: none"> ● Press the whole surface of the marking stamp vertically and evenly onto the template. ● Brush slowly over the template with gentle pressure. ● Marking time 1 - 3 seconds <ul style="list-style-type: none"> ➢ Otherwise, the surface of the workpiece next to the template will be darkened.
9		<ul style="list-style-type: none"> ● The degree of darkness depends on: <ul style="list-style-type: none"> ➢ The marking period, ➢ The electrolyte used, ➢ The material. ● Make sure you do not brush over the edge of the template, otherwise the workpiece surface next to the template will be darkened.



10		<ul style="list-style-type: none"> ● When marking/labelling smaller surfaces, work as follows: <ul style="list-style-type: none"> ➢ Press the whole surface of the marking stamp vertically and evenly onto the template. ➢ Move the marking stamp lightly. ➢ The electrolyte then flows through the template more easily.
11		<ul style="list-style-type: none"> ● Take the template off the workpiece. ● Flush the workpiece surface thoroughly with water. ● Use demineralised or distilled water. <ul style="list-style-type: none"> ➢ The water hardness must be less than 10° dH. ➢ This prevents unsightly lime stains on freshly marked template
12		<ul style="list-style-type: none"> ● Dry the surface. <ul style="list-style-type: none"> ➢ Use paper towels. ➢ In this way, you obtain a stain-free, dry surface.
<p>For more information, see the tips for "marking" and "labelling".</p>		

Table 8 Workflow, dark marking

19.8 Light marking



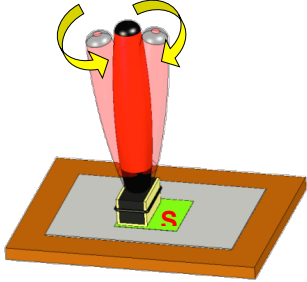
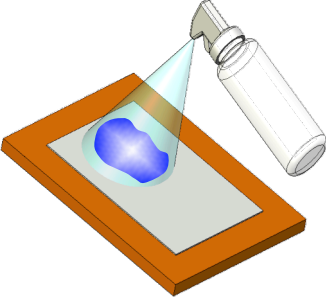



Workflow, light marking		
1		<ul style="list-style-type: none"> ● Prepare the work as for "dark marking"
2		<ul style="list-style-type: none"> ● Switch on the appliance. <ul style="list-style-type: none"> ➢ The mains switch lights up.
3		<p>Safety information</p> <ul style="list-style-type: none"> ➢ Never switch the appliance ON/OFF with the mains switch repeatedly, in quick succession. ➢ These appliances are equipped with an inrush current limiting device, which prevents the circuit-breaker triggering too quickly. ➢ Switching on/off in quick succession may damage the electronics in the appliance. ➢ Wait at least 30 seconds after switching off before switching the appliance on again.
4		<ul style="list-style-type: none"> ● For light marking, set the selector to level "I" <ul style="list-style-type: none"> ➢ Polishing ➢ LED lights up
5		<ul style="list-style-type: none"> ● Proceed as for dark marking
6		<p><i>The marking time is longer, however ~ 3 - 5 sec.</i></p>
7		<p>Safety information</p> <ul style="list-style-type: none"> ➢ Too little electrolyte or an excessively long contact time can cause burning or damage to the film. ➢ Begin therefore with short passes. ➢ Check the success of the marking until the appropriate result is achieved.
<p>For more information, see the tips for "marking" and "labelling".</p>		

Table 9 Workflow, light marking

19.9 Tips for optimal marking / labelling

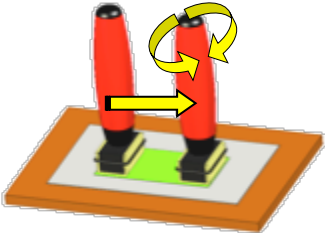

- Every electrolyte contains salts.
 - These can have a strongly oxidising effect, depending on the material.
 - Handle chemicals therefore with great care.
 - Avoid "electrolyte carryover".
 - Wash your hands frequently.
 - Clean the handles and carbon electrodes very thoroughly.
- Never use the same felts for marking/labelling and cleaning.
 - This can otherwise lead to unwanted discolouration of surfaces due to electrolytic carryover.
- Ensure good electrical contact and wet felt.
 - A poorly wetted felt inhibits the current flow.
- Templates get dirty with time due to salts and metal residues.
 - Clean or rinse the templates between labelling processes as well.
- If the label appears rusty.
 - Reduce the marking / labelling period.
- Make sure that the template does not heat up excessively.
 - Otherwise there is a danger of premature wear.
- If too much electrolyte evaporates, the fabric of the template will be glued.
 - In this case, replace the template, otherwise the image will be poor.
- Felts wear out with time, they become dark.
 - Replace dark felts regularly.
- Large typefaces give rise to increased contamination of the felts.
 - Clean the felts regularly.
- The result of the marking / labelling depends on various factors.
- Material variations within a batch of material can influence the result.
 - Test the quality of the font before marking/labelling the workpiece, on a piece of scrap.
- It may be possible to optimise the results by using different electrolytes.
- Use our Neutralyt (see catalogue) to remove electrolyte residues.
 - This prevents subsequent rusting on corrosion-sensitive surfaces.
- Finish your workpiece, if necessary, with a commercially available stainless steel care product.
 - This makes the surface less sensitive to resoiling, e.g. with fingerprints.

20 Possible faults and their remedies

Fault / error message	Possible cause(s)	Remedy
No cleaning effect Although the green control LED is illuminated	<ul style="list-style-type: none"> - Alligator clip not connected - Workpiece / electrolyte temperature too low - M10 thread on the cleaning handle oxidized or dirty 	<ul style="list-style-type: none"> - Switch on appliance - Connect the alligator clip - Clean with a wire brush
Weld or surface is matte	<ul style="list-style-type: none"> - Never remain too long in one place when cleaning - Surface too hot - Insufficient electrolyte - Electrolyte quality too poor or used up 	<ul style="list-style-type: none"> - Never remain too long in one place when cleaning - Cool surface (spray water on the surface) - Increase the amount of electrolyte - Use fresh electrolyte or more highly concentrated electrolyte (SuperCleaner or Polisher)
Felts/carbon fibre brush burn and the electrode gets too hot	<ul style="list-style-type: none"> - Insufficient electrolyte used - Wrong operating level (II) selected 	<ul style="list-style-type: none"> - Dip and cool the electrode in the wide-mouth container more often - Select level I
Polished workpiece surface is matte again	<ul style="list-style-type: none"> - Surface temperature too high 	<ul style="list-style-type: none"> - Do not polish too long in one place - Use more electrolyte more often - Cool occasionally with water
Felts/carbon fibre brushes wear out too fast	<ul style="list-style-type: none"> - Welds are too rough - Too little cooling in the wide-mouth container - Too much pressure when working - Insufficient electrolyte used 	<ul style="list-style-type: none"> - Water hard (use distilled water) - Cool longer in the wide-mouth container - Work with less pressure - Use more electrolyte
Marking does not work	<ul style="list-style-type: none"> - No electrolyte between template and workpiece - In the case of aluminium, possibly anodized surface - Wrong electrolyte 	<ul style="list-style-type: none"> - Wet felt with electrolyte - Remove anodized surface or use non-anodized material - Use suitable electrolyte
Stains after cleaning, polishing, flushing	<ul style="list-style-type: none"> - Not flushed with water thoroughly enough - Limescale, water too hard - Surface too hot due to excessive polishing - Electrolyte residues - Electrolytic carryover through marking residues or electrolytes 	<ul style="list-style-type: none"> - Flush thoroughly with water - Use water with lower hardness - Shorter polishing time - Clean - Clean

Table 10 Possible faults and their remedies

21 Technical Data

Item No.:	EP-01-042	EP-01-040	EP-01-020
Power output [VA]	1000	1000	1000
Weight [kg]	15	14	14
Set weight incl. accessories [kg]	20	19	18
Dimensions [mm]	250 x 150 x 300		
Mains voltage	115/230V / 50Hz / 6A	230V / 50Hz / 6A	230V / 50Hz / 6A
Secondary voltage	10.5-18V AC/DC	10.5-12 V AC/DC	10.5 V AC
Protection class	IP 21		

Table 11 Technical data

22 Clean container, handles and workplace



- Always clean all accessories thoroughly after every use, with plenty of soap and water.
- Rinse the electrode handles, carbon fibre brush and carbons thoroughly, under running water.
- If necessary, wipe the appliance with a slightly damp cloth.
- Neutralise the diluted electrolyte residues.
- Clean your workplace thoroughly, with plenty of water.
- Electrolyte residues can cause chemical burns to the skin or clothing.
- Electrolyte residues can cause damage to the surfaces.
- Remove the felts and dispose of them.
- Wipe the cable and the alligator clip with water and a damp cloth.
- Fill the wide-mouth containers containing the dirty electrolyte with water.
- Dispose of the neutralised electrolyte residues.
- Afterwards rinse the wide-mouth container thoroughly with water, inside and outside.
- Remove any electrolyte residues around your workplace, the work table and the floor, with plenty of water.
- Add commercially available household cleaner or soap to the water.



Safety information

Always unplug from the mains prior to servicing, maintenance and repair work!

23 Maintenance



Note

The following maintenance work may be performed by the user of this appliance:

- All cleaning work on the appliance housing.
- All cleaning work on the accessories.
- Replacement of wear parts
 - Felts, Teflon handles, carbon electrodes, earth clamps, earth cables, marking accessories



Safety information

The following maintenance work must be carried out by a qualified electrician:

- Replacing defective mains plug.
- Replacing defective mains cable.
- Replacing the earth and marking jacks on the appliance.
- Replacing or repairing any components located inside the appliance housing.

23.1 Inspection and maintenance schedule

- Maintenance of the appliance consists of thorough cleaning and inspection by a qualified electrician.
- The frequency depends on the degree of soiling.
- Observe the proposed maintenance intervals.
- Before starting inspection or maintenance work, disconnect the appliance from the mains (pull mains plug).
- Remove dust with a vacuum cleaner.
- Wipe the components with a damp cloth.
- Only use degreasing agents that are suitable for electrical equipment.
- Observe the instructions on cleaning the appliance and accessories.

Inspection and maintenance schedule

Before start = before every start, d = daily, w = weekly, mtl. = monthly, quarterly = every 3 months, half-yearly = every 6 months, annually = every 12 months

Work to be done	Before start	d	w	m	quarterly	half-yearly	annually
Safety check as described in chapter 2.3 and below	X		X				
Check marking felt for wear and replace if necessary	X	X					
Check marking felt for contamination and replace if necessary	X	X					
Check template for contamination and replace if necessary	X	X					
Clean marking handle	X	X					
Check carbon electrodes for contamination and wear, clean or replace if necessary	X						
Clean earth clamps		X					
Check earth clamps for oxidation, clean if necessary			X				
Check electrolyte, if used up--> replace	X	X					
Clean power unit			X				
Maintenance of the appliance						X	
Repeat tests in accordance with VDE 701 A02							X

Table 12 Inspection and maintenance schedule

23.2 Disposal

23.3 Disposal of contaminated electrolytes



- **Never** dispose of undiluted contaminated electrolytes into drains or the environment.
- Heavy metal residues from oxidized welds and metal surfaces can be carried in the contaminated electrolytes.
- These must be filtered out and disposed of properly.
- Dilute electrolytes prior to disposal with plenty of water, lime or Neutralyt to a pH value greater than 5.



Note

We will gladly provide you with a concept for professional water treatment.
Please feel free to contact us.

23.4 Disposal of electronic waste

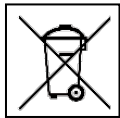

- Old appliances and batteries must not be treated as normal household waste.
- At the end of its service life, this appliance, as well as all components, must be brought to a proper disposal site.
- Take the old appliance and components to a collection point for electronic waste.
- For further information, contact your local waste disposal company or your local authority.

24 Ordering spare and wear parts



Tip for ordering spare and wear parts

For our complete range of products, including all spare and wear parts, see our general catalogue:
http://www.oreuter.de/upload/PDFs/REUTER_Gesamtkatalog_2016_de.pdf

25 Optional accessories

25.1 Teflon sliding sheath

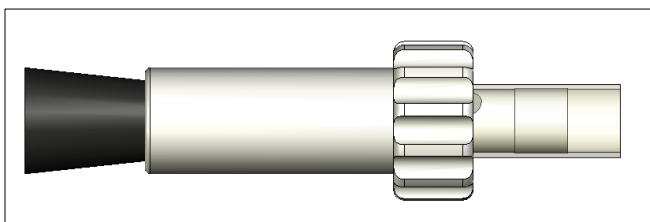

- The Teflon sliding sheath can be used as an alternative to the standard thin Teflon sliding sheath for XL brushes.
- It is manufactured from solid Teflon and withstands even the toughest stress in continuous industrial application.

25.2 Assembly

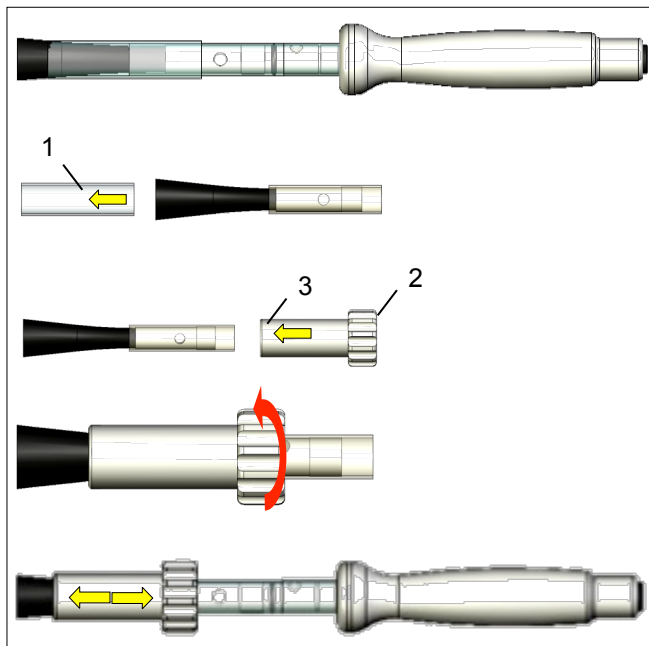

- Remove the original Teflon sleeve (1) from the XL brush.
- Loosen the M22 union nut (2) on the massive Teflon sheath (3) slightly.
- Slide the massive Teflon sheath (3) over the brush.
- Then tighten the union nut (2) slightly.
- In this way, you can move the massive Teflon sleeve (3) with your thumb while you work, without having to stop the cleaning process.
- This ensures that you are always cleaning or polishing with the fibre length best suited to your application.



Note

The sheath is subject to almost no wear and can be used again for new replacement brushes.

25.3 2 and 4-fold brush



Caution!

2- and 4-fold brushes are not usually recommended for Cleanox devices!

The switch-on time is reduced through the use of the multiple brush and the appliance can suddenly switch off much sooner due to overheating!

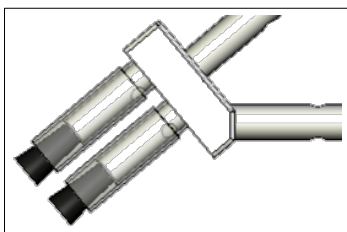

With a 2 and 4-fold brush, you can further increase cleaning and polishing efficiency.



Note

We also always recommend combination with an additional brush extension Item No. EP-02-903.

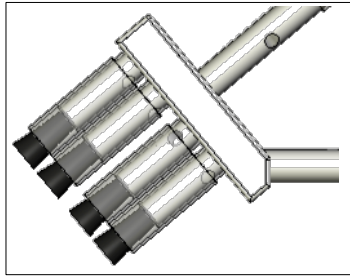

- 4-fold brushes can be used as surface cleaners.
 - This allows cleaning with a width of 100mm in a single work step, or cleaning intensively.
 - You can work in a more relaxed way if you screw the handle, with the extension, on at the side, at an angle of 35°.

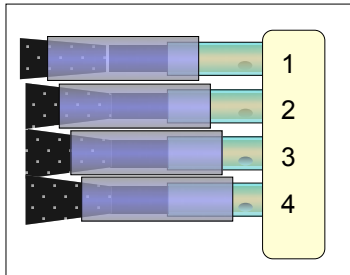

- Brush adjustment:
 - Up to four brushes are placed in succession in the direction of cleaning.
 - Through adjusting the Teflon sheaths on the M brushes to different lengths, you can adjust the performance of the brush.
 - Adjust the carbon fibres of the first brush (in the direction of cleaning) so that approximately 5mm are protruding.
 - As a result, the carbon fibres are more focused and more concentrated light arcs are formed.
- Adjust the subsequent brushes so that the fibres protrude 2-3mm further out each time.

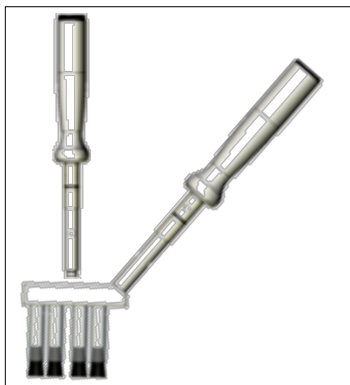

- The fibres of the last brush should protrude approx. 15-20mm.
 - The fibre ends fan out further and bring about a smooth transition at the edge of the weld.

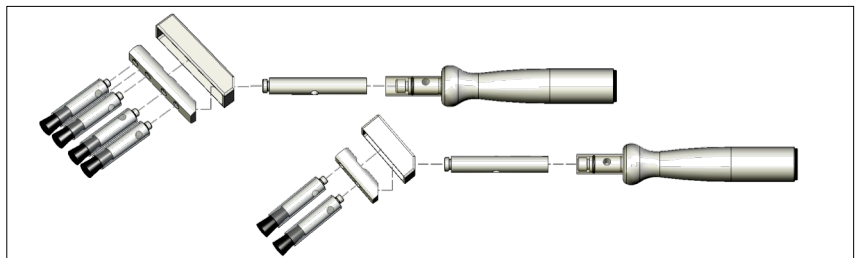

25.4 Extension



- With the optional extension, you can extend the handle as desired by connecting several pieces together, or combine it with knee pieces or multiple brushes, if required.

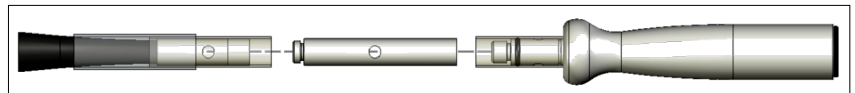

Tip

Using an extension not only increases the operating range, but also keeps your fingers further away from the workpiece so that fewer hot splashes reach your hands.

25.5 Knee piece

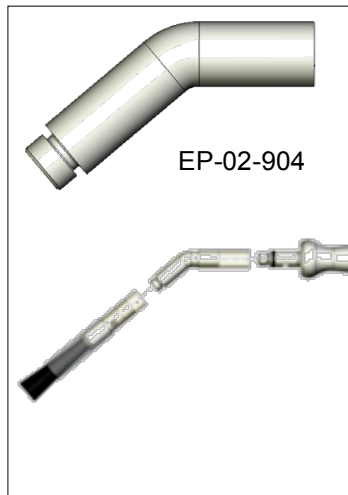

- With the optional knee piece, you can adjust the handle to suit your specific cleaning tasks and workpiece geometries.
- If required, you can combine it with extension pieces or multiple brushes as desired.

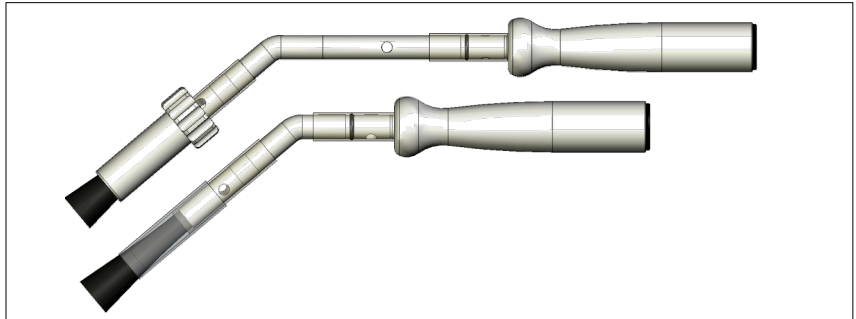

25.6 Adapter brush

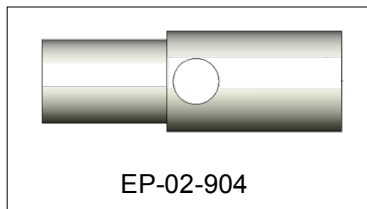

- The optional adapter also allows you to use the small M or S brushes.
 - This enables you to reach the corners more easily.

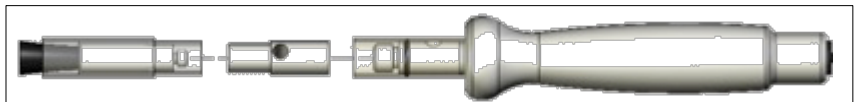

Note

The adapter is absolutely necessary in order to use the M or S brush.

25.7 Printer

Printer type	Description	Item No.:
	<p>PT-9800PCN Professional labelling machine for the PC, network connection, print resolution 360 dpi, band width 18-36 mm, incl. mains cable / USB cable</p>	EP-05-222
	<p>PT-9700PC Professional labelling machine for the PC, print resolution 360 dpi, band width 18-36 mm, incl. mains cable / USB cable</p>	EP-05-202
	<p>PT-E550WVP Professional labelling machine for industrial application, print resolution 180 dpi, band width 18-24 mm, WLAN, incl. Li Ion battery, mains cable / USB cable, carrying case</p>	EP-05-220
	<p>PT-H500 Professional labelling appliance with PC connection, print resolution 180 dpi, band width 18-24mm, supplied without batteries / mains cable incl. USB cable</p>	EP-05-221
	<p>PT-D600VP Professional labelling machine including colour display, print resolution 180 dpi, band width 18-24mm, incl. mains cable / USB cable, carrying case</p>	EP-05-204

Table 13 Printer types

26 EC - Declaration of Conformity



Appliance designation: "Cleanox".

Appliance for the electrochemical cleaning, marking and polishing of metals.

The version of the appliance marketed by us conforms in design and type to the

requirements of the following directives:

- EC Low Voltage Directive 2006/95/EC

Applied standards:

- EN 61558-1 (VDE 0570)

In the case of unauthorized changes, unauthorized repairs, or modifications that are not expressly authorized by the manufacturer, this declaration becomes invalid.

A handwritten signature in blue ink, appearing to read 'O. Rath'.

Erkrath, 04/01/2014

Company stamp / signature