

Alfa Laval PilotUnit Multi

LabUnits and PilotUnits for membrane filtration

Introduction

Alfa Laval offers a range of self-contained small-scale LabUnits and PilotUnits based on the unique LabStak™ (plate-and-frame) modules or the full-fit sanitary spiral membranes, or even a combination of both.

The unit sizes vary from only a few litres of test media volume in the Alfa Laval LabUnits to more than 1,000 litres in the Alfa Laval PilotUnits.

Applications

The Alfa Laval PilotUnit Multi is the ideal tool for easy and reliable scale-up of your process or small-scale production.

It is possible to test all filtration processes: microfiltration, ultrafiltration, nanofiltration (option) and reverse osmosis (option) in batch or semi-batch mode. Diafiltration mode can also be included.

Benefits

- flexible and multipurpose unit to test full range of membrane types (MF, UF, NF and RO)
- suitable for 3.8" spiral membranes in all available feed spacer sizes and for pressure up to 40 barg
- PLC-based control system including flow, temperature, tank level, pressure and diafiltration control
- data logging internal, easy extractable via USB
- compact and space-saving design
- low dead volume (8–12 L)¹ for high product concentration or minimal test media amount
- testing volume of 50–1000 litres
- flexible membrane areas from 3 m² to 15 m²
- suitable for pHt™ membranes with high temperature and pH tolerance
- all components manufactured in compliance with FDA and EU regulations

Scope of supply

The Alfa Laval PilotUnit Multi comprises one housing for a single 3.8" spiral membrane, 40L-tank, pump, heat exchanger, valves, instruments and control system.

The pump system can handle low to high viscosity solutions and operates with feed spacers up to 80 mil.

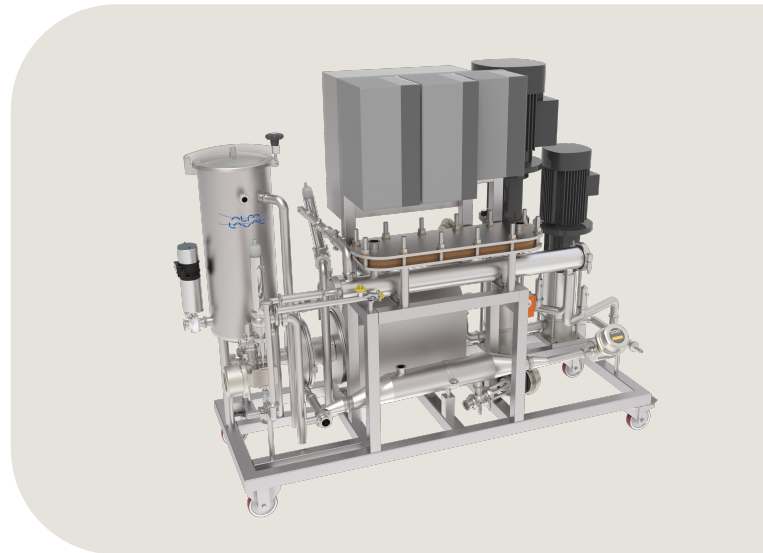

The unit contains a PLC-based regulation control system from which the controllers can be adjusted by the operator. The PLC includes a data logging system for the installed transmitters and the results can be withdrawn on a USB stick.

Options

The basic Alfa Laval PilotUnit Multi (code No. 540000) is further available with the following optional equipment (please specify code number when ordering):

- one additional housing to double the spiral membrane area (code No. 540251)
- one LabStak™ M39H module enabling simultaneous test of different MF/UF flat sheet membranes with up to 2 m² area (code No. 540252)
- one set of high pressure pumps to operate the unit up to 40 bar for nanofiltration and reverse osmosis (code No. 540253)
- online monitoring and data collection
- remote monitoring and control (VNC) and data collection via direct connection on Profinet or Modem connections (secured VPN)

¹ Excluding content of tank

Technical Data

Model	Alfa Laval PilotUnit Multi (basic)	Alfa Laval 3.8" housing (option)	Alfa Laval LabStak™ M39H (option)	Alfa Laval high pressure system (option)
Code number ¹	540000	540251	540252	540253
Membrane area, m ²	3 – 7	3 – 7	2	–
Number of housings	1	1 + 1	–	–
Type of housing	M3.8–1–PN40	M3.8–1–PN40	–	–
Number of spiral membranes	1	1 + 1	–	–
Size of spiral membrane	3838	3838	–	–
Operating pH range ²	1 – 13	1 – 13	1 – 13	1 – 13
Max. operating temperature, °C ²	80	80	80	80
Max. operating pressure, bar ³	8	40	7	40
Cross-flow range, m ³ /hour	6 – 15	–	–	6 – 12
Installed power, kW	11	–	–	16.5
Water consumption, L/CIP sequence	50 – 200	–	–	–
Dry weight, kg	520	12	54	200
Length x width x height, mm	2207 x 761 x 1985	1500 x 220 x 250 ⁴	850 x 260 x 355 ⁴	N/A

¹ Please specify code number when ordering

² For detailed information about operating conditions, please see the specifications for the membrane type applied

³ For detailed information about operating conditions, please see the specifications for the membrane type applied

⁴ No changes added to the footprint of the PilotUnit Multi

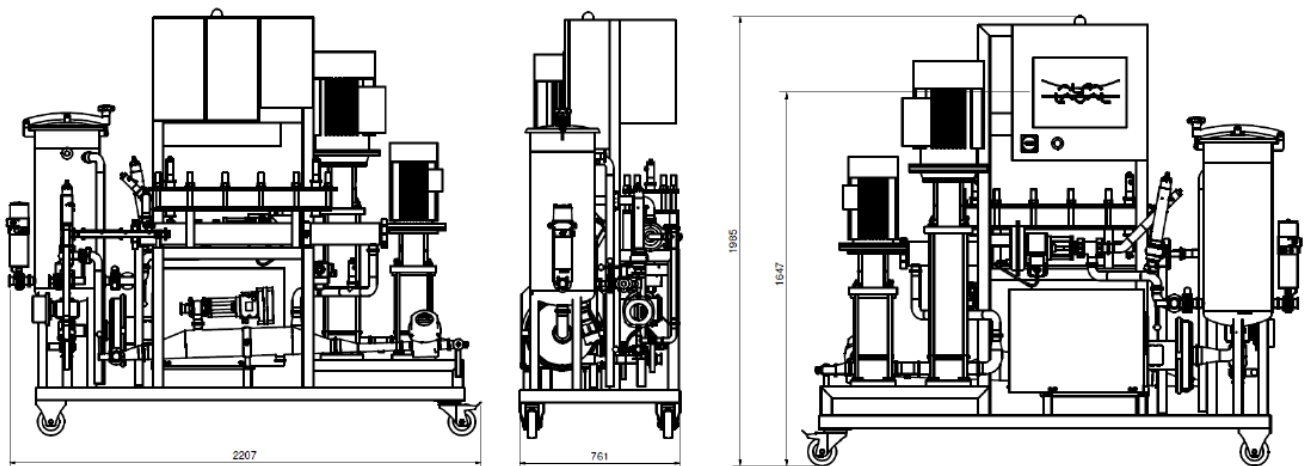

Components

Model	Alfa Laval PilotUnit Multi (basic)	Alfa Laval 3.8" housing (option)	Alfa Laval LabStak™ M39H (option)	Alfa Laval high pressure system (option)
Module	Housing 1 x M3.8–1 for spiral membrane size 3838	Housing 1 x M3.8–1 for spiral membrane size 3838	LabStak™ M39H for M39 flat sheet membranes	—
Support and spacer plates	—	—	Polysulphone (PSO)	—
High pressure pumps, 2 pieces	—	—	—	Grundfos CRM10–9/17
Cross-flow pump, 1 piece	Alfa Laval SolidC-3	—	—	—
Heat exchanger, 1 piece	WILA, 1 m ²	—	—	—
Valves	Alfa Laval	—	—	Alfa Laval
Flow and conductivity combined transmitters	Endress+Hauser Promag	—	—	—
Pressure transmitters	Endress+Hauser Cerabar	—	—	—
Temperature transmitter	Endress+Hauser Easytemp	—	—	—
Level transmitter	Endress+Hauser Deltapilot	—	—	—
O-ring set	EPDM	EPDM	EPDM	—
PLC	Siemens 1500	—	—	—
MCC — inverter(s)	Danfoss FC302	—	—	Danfoss FC302
Internal, product wetted steel	AISI 316L	AISI 316L	AISI 316L	AISI 316L
Internal sheet / welds, Ra	≤ 0.8 / 1.6 µm	≤ 0.8 / 1.6 µm	≤ 0.8 / 1.6 µm	—
Wheels	Plastic / stainless steel	—	—	—

Connections

Alfa Laval PilotUnit Multi

Feed / water inlet	DN38, ISO 2852 clamp
Retentate outlet	DN38, ISO 2852 clamp
Permeate outlet	DN25, ISO 2852 clamp
Cooling / heating water in / out	DN38, ISO 2852 clamp
Main drain	DN38, ISO 2852 clamp
Drain permeate line	DN25, ISO 2852 clamp
Compressed air	½" BSP female / OD10 mm hose
Electrical power	3 x 460 V + PE, 50/60 Hz, 3 m cable

Note: The Alfa Laval PilotUnit Multi is supplied with 1" hose nipple adaptor for all clamp connections

This document and its contents are subject to copyrights and other intellectual property rights owned by Alfa Laval Corporate AB. No part of this document may be copied, re-produced or transmitted in any form or by any means, or for any purpose, without Alfa Laval Corporate AB's prior express written permission. Information and services provided in this document are made as a benefit and service to the user, and no representations or warranties are made about the accuracy or suitability of this information and these services for any purpose. All rights are reserved.

How to contact Alfa Laval

Up-to-date Alfa Laval contact details for all countries are always available on our website at www.alfalaval.com