

FV565901

FILLING LEVEL SENSORS • SWITCHING AMPLIFIERS

Filling level and level sensors operate according to different measuring principles. The selection of the sensor depends on the medium to be detected and the ambient conditions. The material flow in a vibratory bowl can be excellently queried with inductive filling level sensors whose pendulum is moved by the material in the pot. The detection of liquid or solid media is, for instance, possible with capacitive filling level sensor technology. These work according to the principle of the condenser, the medium changes the dielectricity between two electrodes. The resulting change is converted into a digital output signal. A further alternative for the detection of filling levels of conductive media is provided by conductive filling level relays. The resistance between reference and measuring electrode is determined. If a set threshold is exceeded, a relay output switches.



MECHANICAL FEATURES

Degree of protection (IP)	IP20
Depth	114.5 mm
Device design	Field device
Height	22.6 mm
Housing design	Cuboid
Housing material	Polyamide
Length	113.6 mm
Mounting method	DIN rail
Width	99 mm

ELECTRICAL FEATURES

Conductive filling level amplifiers	+
Galvanic isolation between input and output	+
Galvanic isolation between inputs	+
Galvanic isolation between supply voltage and all other current circuits	+
Inherently safe according to EN 60947-5-6 NAMUR	-
Malfunction message output	-
Number of channels	2
Output circuit, relay change-over contact	2
Power consumption	10 W
Rated supply voltage at AC	20 V ... 253 V
Rated supply voltage at DC	20 V ... 253 V
Reverse polarity protection	+
Suitable for safety functions	-
Switching capacity	2500 VA
Switching current	10 A
Switching voltage	250 V
Type of electrical connection	Clamps
Type of voltage supply	Active
Voltage type	AC/DC
With LED display	+

OTHER FEATURES

Operating temperature	-40 °C ... 70 °C
-----------------------	------------------

Other

Packaging dimensions	105.0mm x 30mm x 130mm
Shipping weight	0.18kg
Tariff code	85365019

Classification

ipf product group	350
eClass 8.0	27371813
eClass 9.0	27371813
eClass 9.1	27371813
ETIM-5.0	EC001485
ETIM-6.0	EC001485
ETIM-7.0	EC001485

Connection

Dimensional drawing

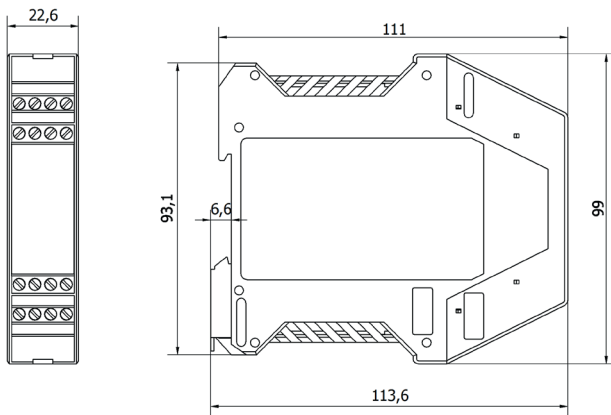

Installation



Mounting / installation may only be carried out by a qualified electrician!

Disposal



Software

Please download the software or driver required for operating your new device on our homepage: www.ipf.de

Safety warnings

Before initial operation, please make sure to follow all safety instructions that may be provided in the product information. Never use these devices in applications where the safety of a person depends on their functionality. LED lighting systems can generate intensive UV radiation, which can damage your eyes in case of improper use. The manufacturer cannot be held responsible for damages that result from improper use or connection.