

FS94C375

FILLING LEVEL SENSORS • CONDUCTIVE

sensor filling level, Conductive, 1.1/2 inch 1652long, 1.1/2 inch, 100°C, Amplifier Amplifier, Clamp 4pin, Polyamid+Stainless steel 1.4571, IP65, probe 4x Ø4mm 1600long

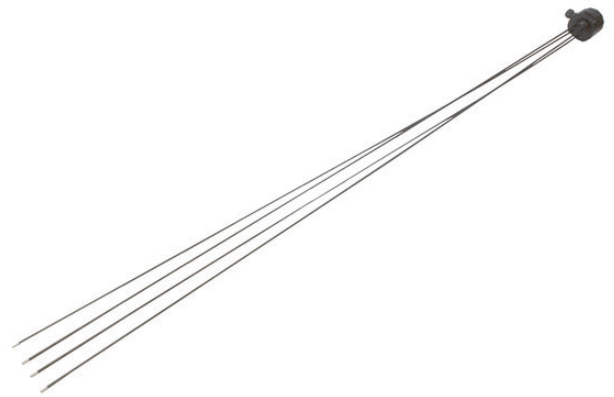

MECHANICAL FEATURES

Ambient temperature	-10 °C ... 100 °C
Degree of protection (IP)	IP65
Design	Special construction
Housing material	Polyamide
Increased ambient temperatures > 80°C	+
Medium temperature	-20 °C ... 100 °C
Pressure resistance	10 bar
Probe diameter	4 mm
Probe length	1600 mm
Sensing element material	Stainless steel 1.4571
Sensor diameter	40 mm
Sensor height	52 mm
Sensor length	1652 mm
Thread length	15 mm
Thread size, inches	1.1/2 inch
Type of process connection	1.1/2 inch

ELECTRICAL FEATURES

Number of pins	4
Number of probes	4
Physical measurement principle	Conductive
Type of electrical connection	Clamps
Type of switching function	Amplifier
Type of switching output	Amplifier

Other

Packaging dimensions	150mm x 110mm x 1650mm
Shipping weight	1.11kg
Tariff code	85365019

Classification

ipf product group	350
eClass 8.0	27371813
eClass 9.0	27371813
eClass 9.1	27371813
ETIM-5.0	EC001447
ETIM-6.0	EC001447
ETIM-7.0	EC001447

Connection

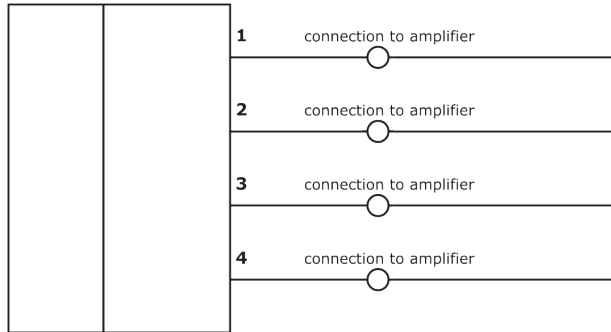

Dimensional drawing

Installation



Mounting / installation may only be carried out by a qualified electrician!

Disposal



Software

Any software, drivers or IODD files that may be required to operate your device can be downloaded free of charge from our homepage: www.ipf-electronic.com

Safety warnings

Before initial operation, please make sure to follow all safety instructions that may be provided in the product information. Never use these devices in applications where the safety of a person depends on their functionality. LED lighting systems can generate intensive UV radiation, which can damage your eyes in case of improper use. The manufacturer cannot be held responsible for damages that result from improper use or connection.