

SL950020

FLOW SENSORS • SENSORS FOR AIR

The function of the flow sensor is based on the calorimetric principle. The probe is heated up from the inside a few degrees Celsius in relation to the flow medium, in which it protrudes. When the medium flows, the heat generated in the probe is dissipated through the medium. The temperature within the sensor is measured and compared with the likewise measured medium temperature. From the obtained temperature difference the flow state of each medium can be derived. These sensors are applied in areas such as monitoring of cooling systems, ventilation systems, pump dry running by checking the presence of liquid or gas flows.

MECHANICAL FEATURES

Ambient temperature for evaluation electronics	-20 °C ... 70 °C
Degree of protection (IP) of evaluation electronics	IP65
Degree of protection (IP) of measuring head	IP65
Depth	75 mm
Height	195.9 mm
Housing design	Cuboid
Housing material	Polycarbonate
Medium temperature	-30 °C ... 80 °C
Pressure resistance	16 bar
Sensing element material	Stainless steel 1.4301
Temperature medium	-30 °C ... 80 °C
Type of process connection	R 2 inch
Width	475 mm

ELECTRICAL FEATURES

Air conditioning / ventilation systems	+
Flow measurement	+
Flow range for air	33.33 l/min
Flow range for air	19916.66 l/min
Max. output current	150 mA
Measuring head integrated in device	+
Measuring principle of flow	Calorimetric
No-load current	120 mA
Number of pins	5
Number of switching outputs	1
Number of switching points	2
Operating voltage	18 V ... 36 V
Pressure resistance of measuring head	16 bar
Rated control supply voltage U_s at DC	18 V ... 36 V
Reverse polarity protection	+
Setting procedure	Parameterization
Short-circuit protection	+
Switching current	0.15 A

ELECTRICAL FEATURES

Switching voltage	48 V
Transistor output	+
Type of analog output	4 mA ... 20 mA
Type of electrical connection	Plug-in connection M12
Type of interface	EV003727
Type of switching function	Normally open contact (NO)
Type of switching output	Relay contact
Voltage type	DC
With display	+
With LED display	+

OTHER FEATURES

For pneumatic applications	+
Suitable for gases	+
Suitable for liquids	-

Other

Packaging dimensions	170mm x 230mm x 500mm
Shipping weight	3.03kg
Tariff code	90261021

Classification

ipf product group	300
eClass 8.0	27371815
eClass 9.0	27371815
eClass 9.1	27371815
ETIM-5.0	EC002580
ETIM-6.0	EC002580
ETIM-7.0	EC002580

Connection

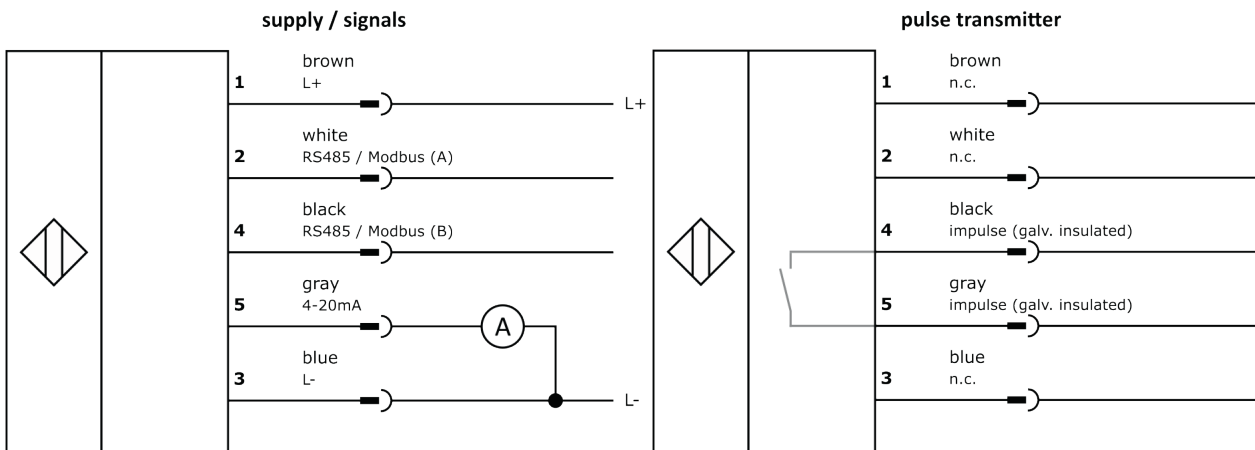

Dimensional drawing

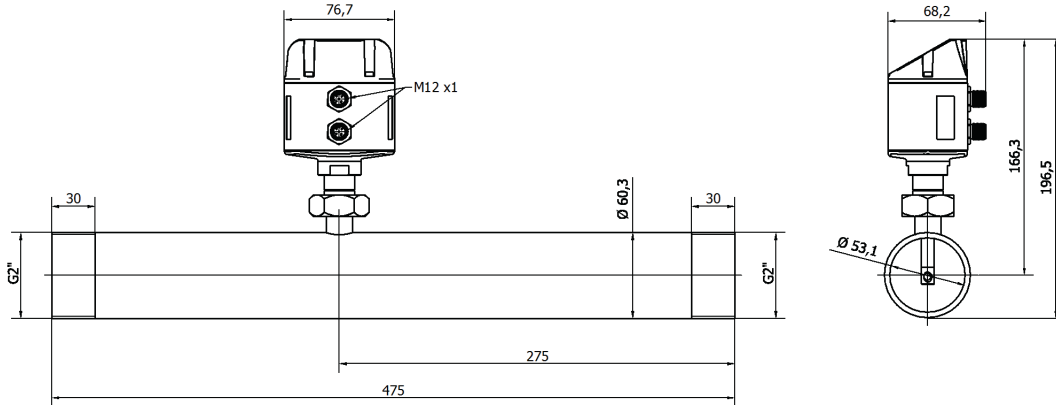

Installation



Mounting / installation may only be carried out by a qualified electrician!

Disposal



Software

Please download the software or driver required for operating your new device on our homepage: www.ipf.de

Safety warnings

Before initial operation, please make sure to follow all safety instructions that may be provided in the product information.

Never use these devices in applications where the safety of a person depends on their functionality.

LED lighting systems can generate intensive UV radiation, which can damage your eyes in case of improper use. The manufacturer cannot be held responsible for damages that result from improper use or connection.