

VD58E264

ROTARY ENCODERS • ENCODERS

A rotary encoder is a device that converts a rotary motion into a digital output signal, which can be processed on a subsequent evaluation electronics. All of our encoders operate according to the principle of optical scanning. Inside the device there is a pulse disc on which is – depending on the encoder - a unique (absolute) or repetitive (incremental) line graduation, which is scanned by an optical system. The turning of the encoder shaft causes rotation of the pulse disc, which results in a corresponding sampling signal of the optical system. This is finally implemented by an integrated electronics in encoder-specific output signals (e.g. multi-turn, RS422 etc.). For professional installation in many applications, shaft couplings or resilient bases for mounting brackets or flanges are used. In addition, the encoder shaft can be equipped with measuring wheels or pinions in various designs and sizes. Typical applications include the angle measurement on bending machines, length measuring of belt systems or speed measurement on winding systems.



MECHANICAL FEATURES

Ambient temperature	-40 °C ... 85 °C
Axial load capacity of shaft	40 N
Degree of protection (IP)	IP67
Encoder size	58
Housing material	EV001084
Max. rotation speed	6000 UpM
Moment of inertia	15.38 gcm ²
Radial load capacity of the shaft	80 N
Sensor diameter	58 mm
Sensor length	63.8 mm
Shaft diameter	10 mm ... 10 mm
Shock resistance, acceleration	500 g
Shock resistance, pulse time	1 ms
Torque	0.025 Nm
Type of encoder shaft	Full shaft
Version	Absolute encoder
Vibration resistance, acceleration	30 g
Vibration resistance, frequency	2000 Hz
With shaft sealing ring	+

ELECTRICAL FEATURES

Absolute position value collection	Multiturn
No-load current	20 mA
Number of pins	5
Number of steps per revolution (MAX)	16384
Physical measurement principle	Magnetic
Programmable	-
Reverse polarity protection	+
Shaft length	20
Short-circuit protection	+
Suitable for absolute value detection	+
Supply voltage	10 V ... 30 V
Track A inverted	-

ELECTRICAL FEATURES

Type of electrical connection	Connector M12
Voltage type	DC

OTHER FEATURES

Relative air humidity	95 %
Single-turn encoder	-

Other

Packaging dimensions	0.0mm x 0.0mm x 0.0mm
Shipping weight	0.44kg
Tariff code	90318020

Classification

ipf product group	700
eClass 8.0	27270590
eClass 9.0	27270590
eClass 9.1	27270590
ETIM-5.0	EC001486
ETIM-6.0	EC001486
ETIM-7.0	EC001486

Connection

Dimensional drawing

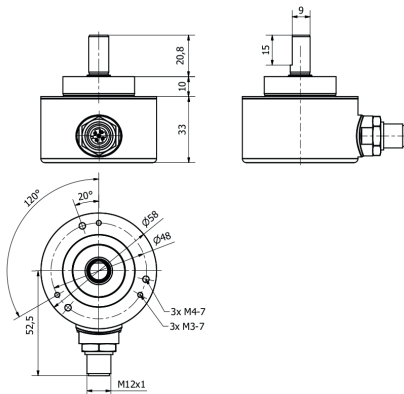

Installation



Mounting / installation may only be carried out by a qualified electrician!

Disposal



Software

Please download the software or driver required for operating your new device on our homepage: www.ipf.de

Safety warnings

Before initial operation, please make sure to follow all safety instructions that may be provided in the product information. Never use these devices in applications where the safety of a person depends on their functionality. LED lighting systems can generate intensive UV radiation, which can damage your eyes in case of improper use. The manufacturer cannot be held responsible for damages that result from improper use or connection.