

HYDRAULIC RETURN FILTERS

TANK MOUNTED RETURN FILTER 1" - 60 MICRON – 220LT.

Construction	Aluminium head casting, Steel Bowl (05 series Nylon 66.)
Seals	Nitril
Max. Working Pressure	10 bar
Operating Temperature	-10°C~ +100°C
Bypass Crack Pressure	1,5bar ± 0,3 bar
Port Size	G 1"
Filtration	60μ
Flows	220lt/min.
Suitable Element	T12-3-3-0038 / FILTER ELEMENTS_60M_220L

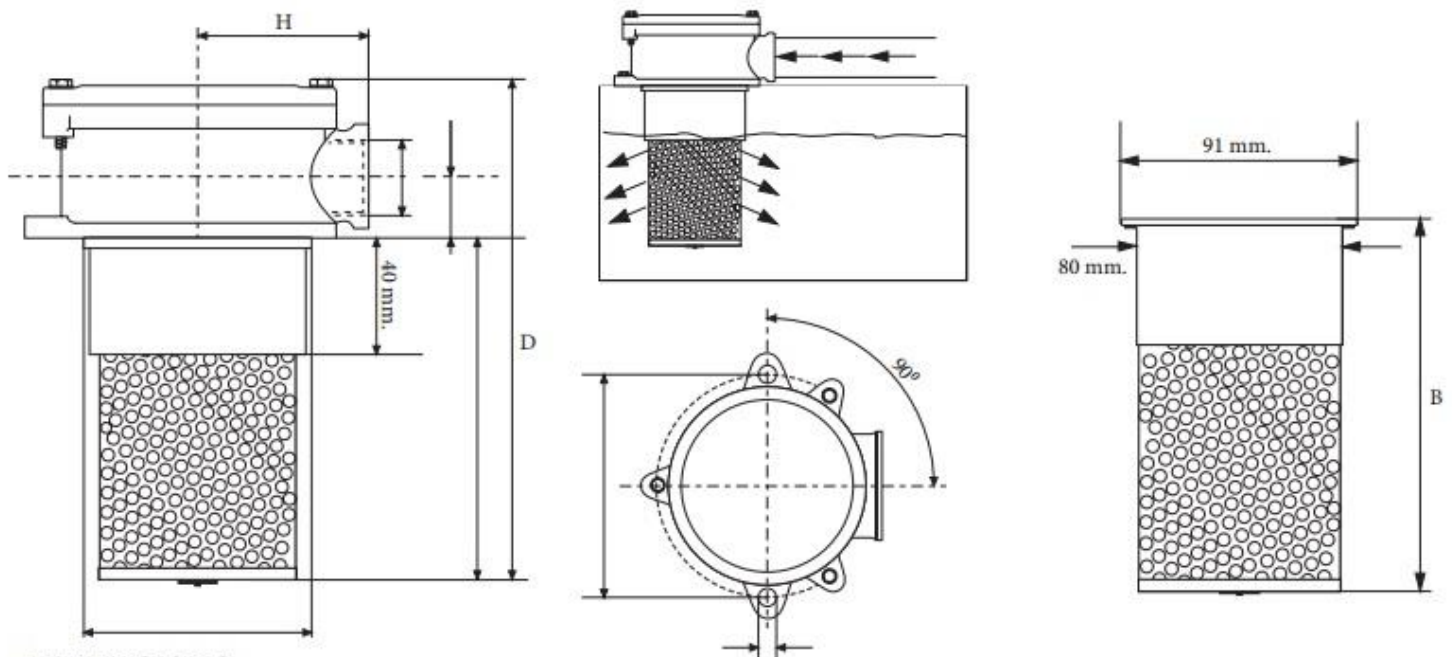

DIMENSIONS

PRODUCT NUMBER	FLOW (Δp 0,25)lt/dk.	G	A	B	C	D	E	F	H	I
T12-3-3-0028	220	1"	115	180	165	235	87	30	66	9

REPLECEMENT ELEMENT	FILTER MEDIA	FILTER AREA cm ²
T12-3-3-0038	60μ	1450