

RX3

UHF RFID-ANT Integrated Module

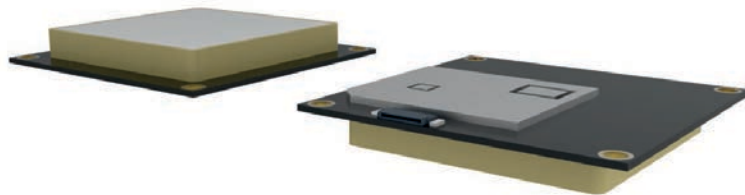

1. Advantages

- Phychips Pr9200 inside with outstanding performance and cost-effective value
- 1.2mm ultra thin design for back components
- Ultra low power consumption without cooling concern
- Wide temperature design with very low temperature drift coefficient
- Stable read distance up to 3m (tested with Impinj E41b inlay)
- Full compatible with different communication interfaces of INDY R2000 series products

2. Comparison (tested with Impinj E41b inlay)

2-1 RX3

Size : 50*50*7.2mm

Weight : 60g

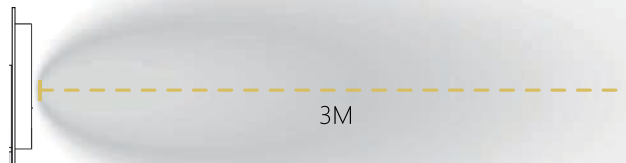

3. Dimensions (unit: mm)

Any discrepancy, please defer to the real product instead.

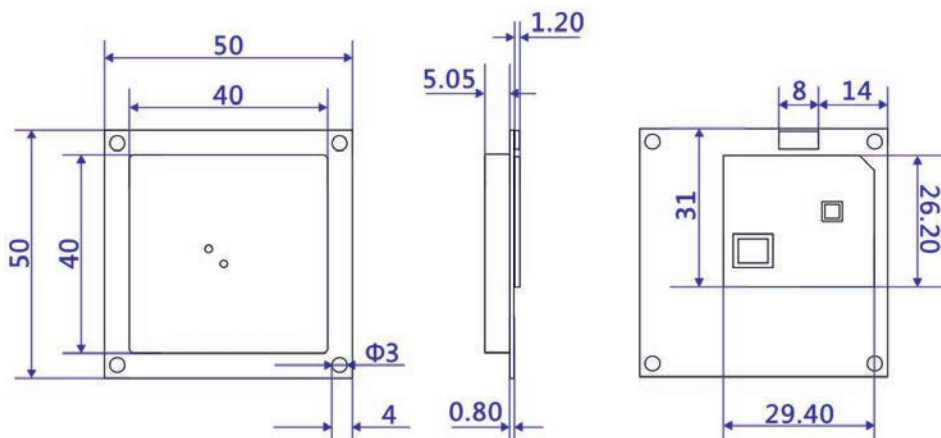
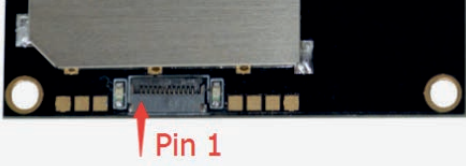

Figure 3-1 RX3 Dimensions

4. PIN Assignments

PIN Assignments



4-1 Pin 1

FPC Connector (12Pin , spaces between PINs: 0.5mm)

PIN	Interface	Description
1	VCC	Power Supply DC 3.6V-5.5V
2	VCC	
3	GND	Grounding
4	GND	
5	EN	High Level Enabling
6	Trigger	Trigger (High Level Available under 09 Mode)
7	RXD	UART RXD
8	TXD	UART TXD
9	Beeper	Buzzer Control, external buffer needed
10	GPIO3	Output IO3
11	GPIO4	Output IO4
12	GND	Grounding

5. Circuit Design Reference

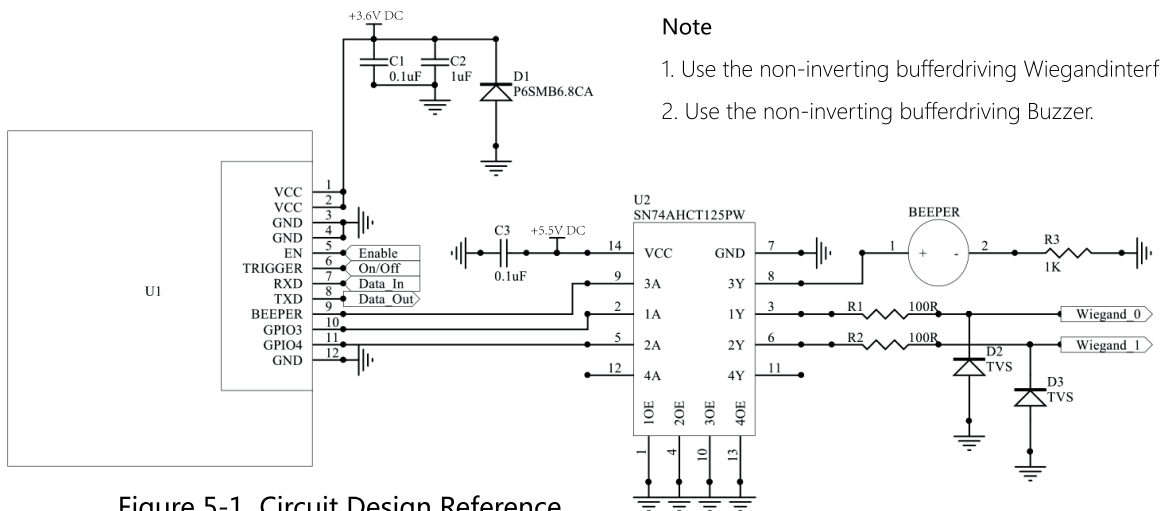

Note

1. Use the non-inverting bufferdriving Wiegandinterface.
2. Use the non-inverting bufferdriving Buzzer.

Figure 5-1 Circuit Design Reference

6. Electrical Parameters

Electrical Parameters				
Input Voltage	DC 3.6V ~ 5.5V			
Standby Mode Current	< 50mA (EN High Level)			
Sleep Mode Current	< 100µA (EN High Level)			
Operating Current	Conditions	Min	Type	Max
	@5V(26dBm Output , 25°C)		180mA	400mA
Operating Temperature	-20°C~+70°C			
Storage Temperature	-20°C~+85°C			
Operating Humidity	< 95% (+25°C)			
Air Interface Protocol	EPCglobal UHF Class 1 Gen 2 / ISO 18000-6C			
Spectrum Range	902 ~ 928MHz, 865 ~ 868MHz Optional ✓			
Supported Regions	US, Canada and other regions following U.S. FCC			
	Europe and other regions following ETSI EN 302 208			
	China, Korea, Malaysia			
Output Power	18 ~ 26dBm			
Output Power Precision	+/- 1dB			
Output Power Flatness	+/- 0.2dB			
Receive Sensitivity	< -70 dBm			
Peak Inventory Speed	> 50 tags/ sec			
Tag Buffer Size	200 tags @ 96 bit EPC			
Tag RSSI	Supported			
Communication interface	Uart 3.3V			
GPIO	1 input 2 output (3.3V TTL Level)			
Baud Rate	115200 bps(default and recommended), 38400bps			
Antenna	2dBi ceramic antenna			
Cooling	Air cooling			