

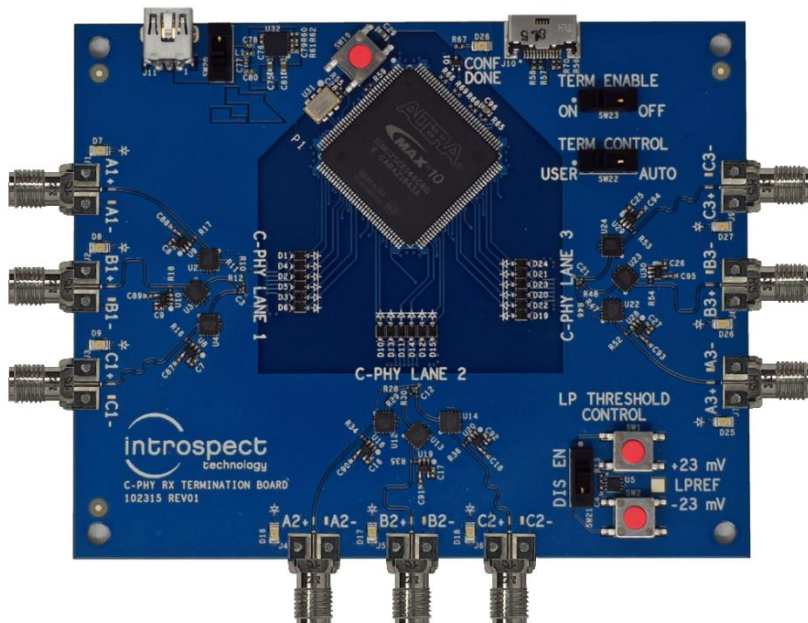

TECHNICAL INSIGHTS

# Rapid Signal Integrity Measurement with the Introspect MIPI C-PHY Reference Termination Board



## Table of Contents

Table of Contents .....	2
Introduction .....	3
Overview .....	3
Configuring the Reference Termination Board .....	4
Providing Input Power .....	4
Termination Control .....	4
LP Threshold Control .....	4
Connections to the Device Under Test .....	4
Convenient Probe Attachment Points .....	6
Signal Integrity Measurement Examples .....	6
Additional Documentation .....	9

# Introduction

## OVERVIEW

Introspect Technology’s CRTB MIPI C-PHY Reference Termination Board (RTB) emulates the behavior of a MIPI C-PHY receiver at data rates up to 6.5 Gbps. The RTB is used for high-performance C-PHY transmitter testing including signal integrity characterization and CTS compliance testing. This Technical Insights article will show how quickly and easily the RTB can be configured for use with any C-PHY transmitter device under test (DUT). Convenient probing points are available on the RTB for signal observation with an oscilloscope. The physical ports and controls of the RTB are shown in Figure 1 below.

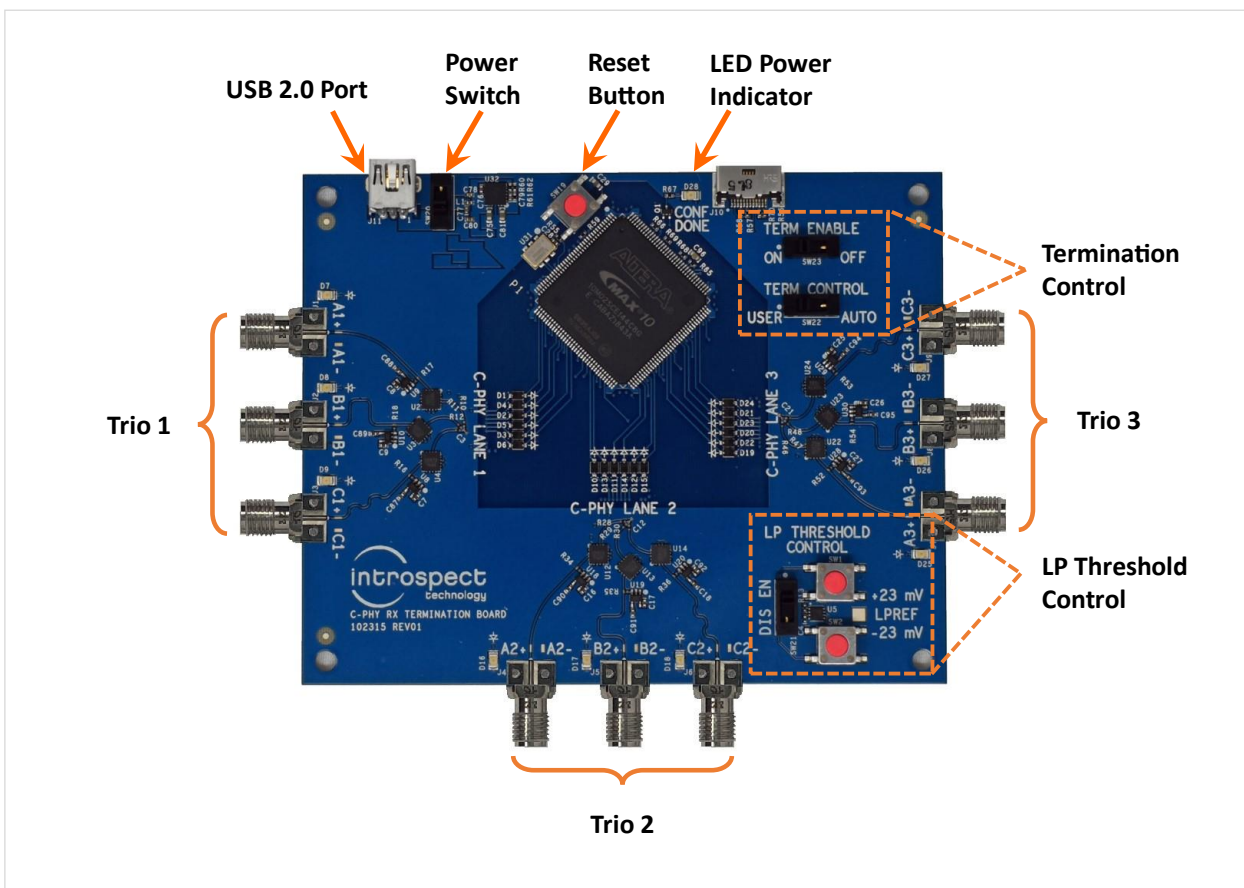

Figure 1: Physical ports and controls of the CRTB MIPI C-PHY RTB board

## Configuring the Reference Termination Board

### PROVIDING INPUT POWER

Power to the RTB is provided through the 5V supply on USB 2.0 Port connector.

### TERMINATION CONTROL

The termination control section of the RTB, as labelled in Figure 1, allows users to switch between automatic or user-controlled termination. When operating in the automatic mode, the RTB will automatically turn on high-speed termination when an incoming MIPI C-PHY HS signal transmission is detected. When operating in the user-controlled mode, the RTB high-speed termination may be manually enabled or disabled via the "Termination Enable" switch.

### LP THRESHOLD CONTROL

The LP threshold control section of the RTB, as labelled in Figure 1, allows for adjustment of the LP threshold voltage used to detect the start and end of high-speed transmissions. The LP threshold is set by pushing the "+23mV" or "-23mV" buttons to raise or lower the threshold voltage in 23mV increments.

Additional programming and usage details for the RTB can be found in the MIPI C-PHY Reference Termination Board Quick Start Manual, as listed at the end of this document.

## Connections to the Device Under Test

A block diagram for connecting a C-PHY transmitter device under test (DUT) to the RTB is shown in Figure 2. The RTB provides standard female SMA connectors for up to three C-PHY trios. Active probes can be used to drive the received signal to an oscilloscope. Quick single-ended or differential probing can be achieved easily with hand-held browser instruments on the RTB, as demonstrated in Figure 3(a). Complete monitoring of an entire C-PHY trio can be achieved with multiple solder-down probes, as shown in Figure 3(b).

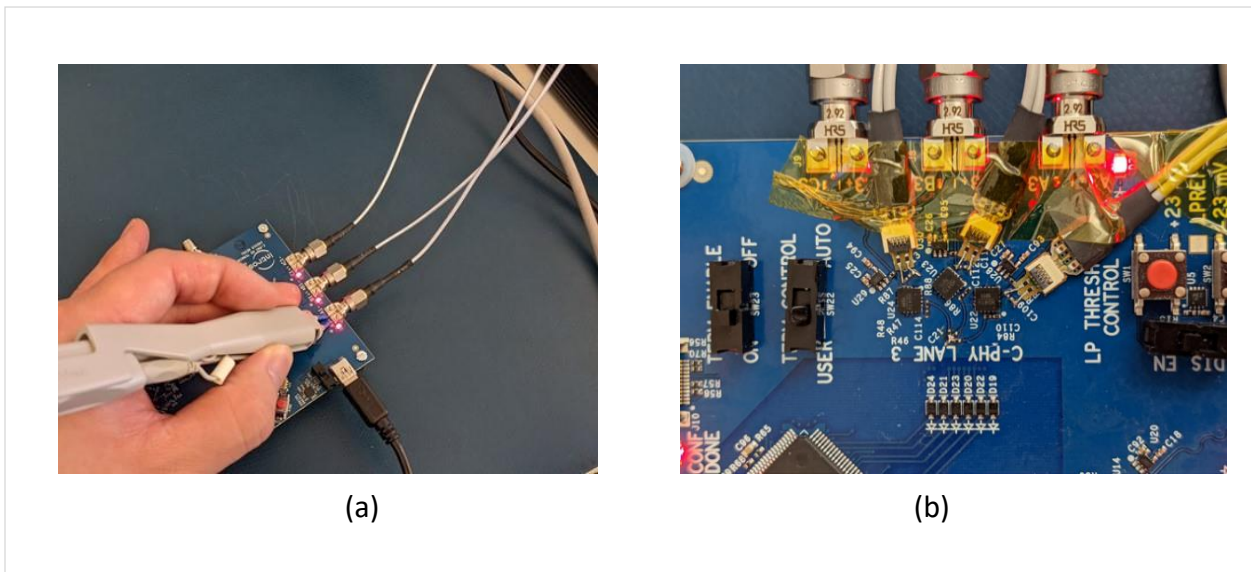
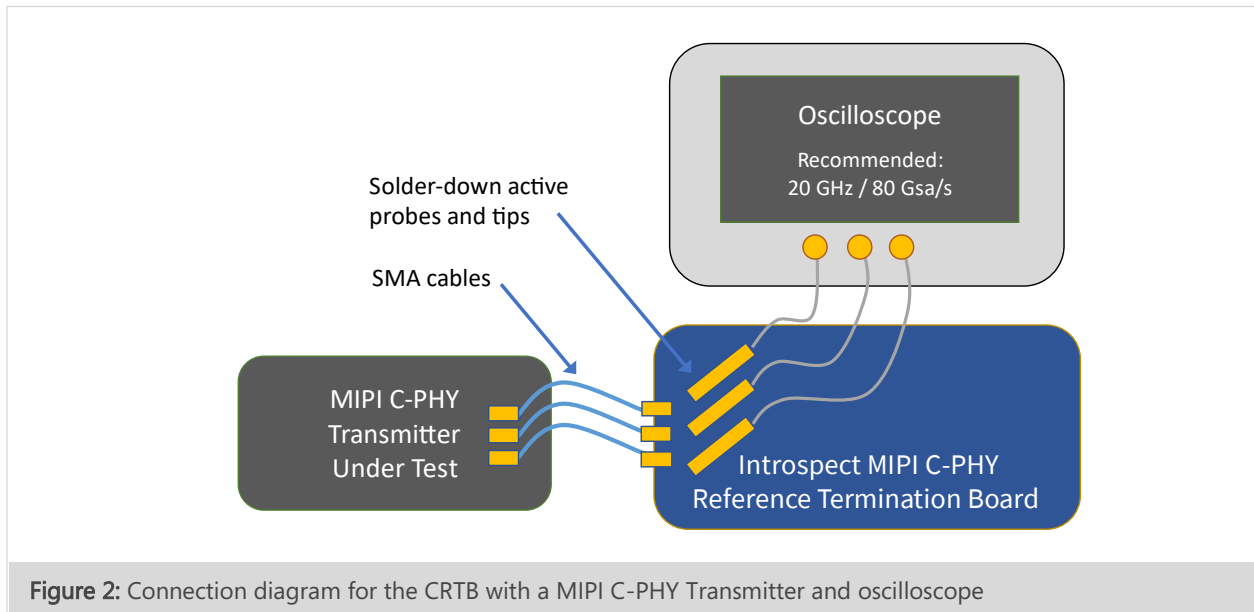

Figure 3: (a) Demonstration of using a hand-held browser for single ended or differential probing on the RTB  
(b) Demonstration of using solder-down probes for complete monitoring of a C-PHY trio

## Convenient Probe Attachment Points

A diagram of probe attachment points on the RTB is shown in Figure 4. Components include an optional damping resistor (marked in purple) and convenient signal and ground pads (marked in red and green). The footprint used for both the damping resistor and probe signal and ground landing points are from a standard 0201 package.



Figure 4: Probe attachment points for one lane (trio) on the RTB

## Signal Integrity Measurement Examples

The following section provides some visual examples of signal integrity testing performed using the Introspect MIPI C-PHY Reference Termination Board. All measurements have been made using a 20 GHz oscilloscope with 12 GHz active probes attached to the RTB.

An example of verifying the LP to HS transitions and  $T_{LPX}$  timing controls is shown in Figure 5. The DUT is operating at 2.0 Gbps and the LP001 timing has been programmed to 50 ns and 100 ns settings respectively. The transition between LP and HS is handled automatically by the RTB as shown.



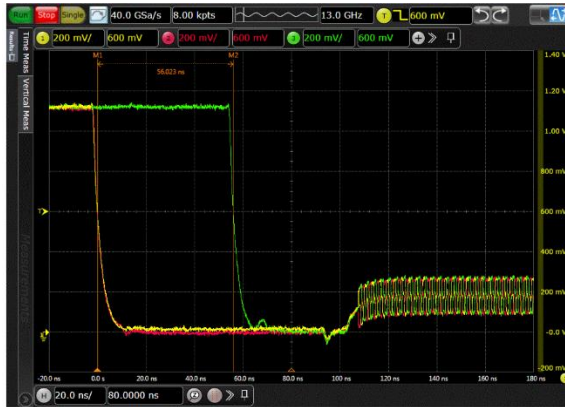

(a)



(b)

Figure 5: Examples of T<sub>Lpx</sub> timing measurements on a CPHY transmitter (a) LP001 set to 50 ns and (b) LP001 set to 100 ns

An example of C-PHY transmitter common-mode voltage testing is shown in Figure 6. The common mode settings used on the DUT were -200 mV and +600 mV respectively.

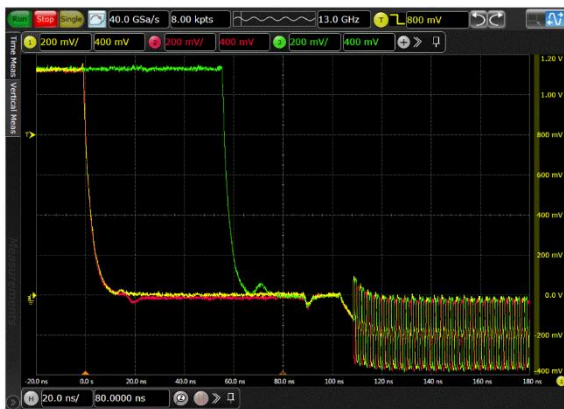

(a)



(b)

Figure 6: Examples of common-mode voltage measurement (a) DUT CM set to -200mV and (b) DUT CM set to 600 mV

Examples of triggered eye measurements made using the RTB are shown in Figure 7. The signal source for these triggered eye measurements was the Introspect SV5C-CPTX programmed to 250 mV HS amplitude. At 6.5 Gsps, a typical eye width of 90 ps and eye height of 100 mV are observed, showcasing the high signal integrity measurement capabilities achieved with the Introspect MIPI C-PHY Reference Termination Board.

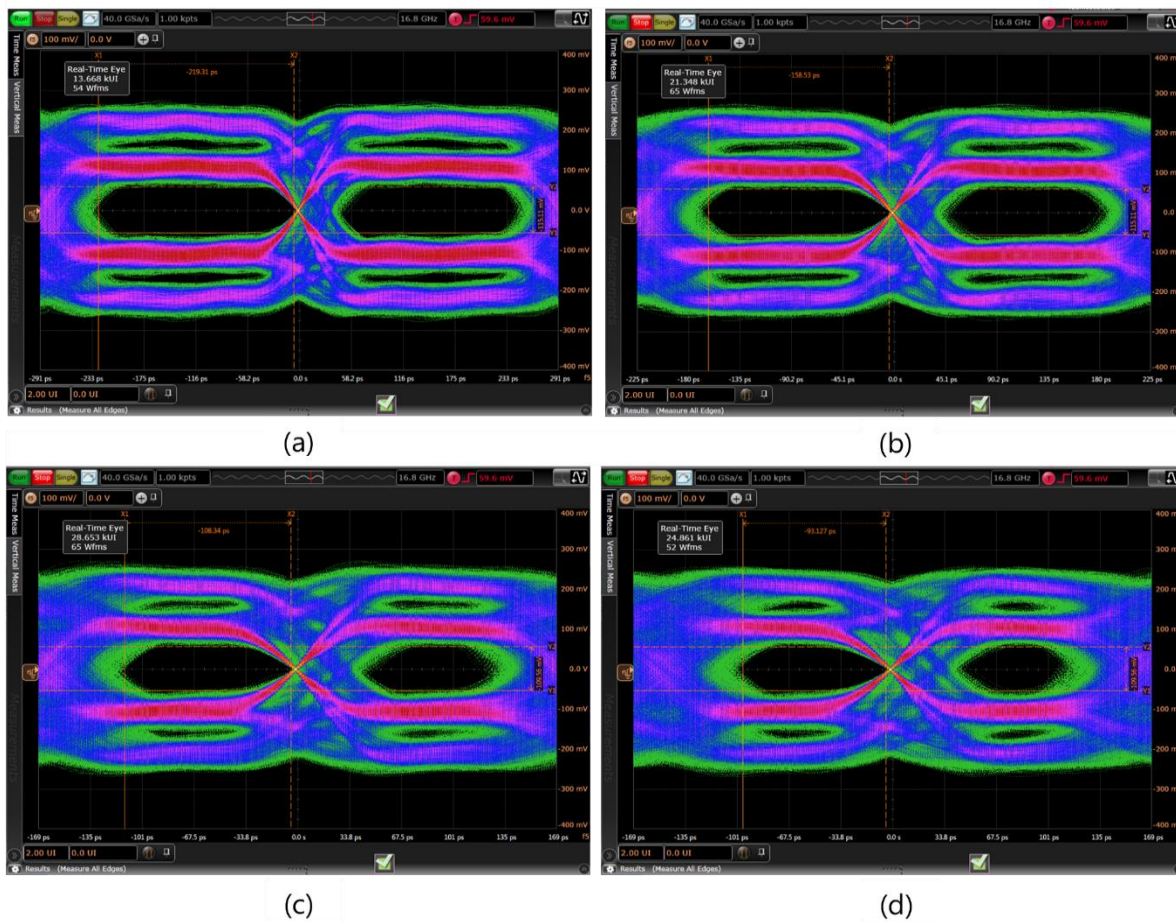

Figure 7: Examples of triggered-eye measurements at (a) 3.5 Gsps, (b) 4.5 Gsps, (c) 6.0 Gsps, and (d) 6.5 Gsps

For additional information, please refer to the documents on the following page, and for any technical questions, please contact our Customer Support Team at [support@introspect.ca](mailto:support@introspect.ca).



## Additional Documentation

CRTB MIPI C-PHY Reference Termination Board Data Sheet

- EN-D032E-E-21195 CRTB MIPI C-PHY Termination Board Data Sheet

CRTB MIPI C-PHY Reference Termination Board Quick Start Manual

- EN-G039E-E-21195 CRTB MIPI C-PHY Termination Board Quick Start Manual

SV5C-DPTXCPTX Data Sheet

- EN-D017E-E-20209 SV5C-DPTXCPTX Data Sheet



Revision Number	History	Date
1.0	Document Release	July 14, 2021

The information in this document is subject to change without notice and should not be construed as a commitment by Introspect Technology. While reasonable precautions have been taken, Introspect Technology assumes no responsibility for any errors that may appear in this document.