

elite Series



AVA LED

CR-IR 2" P2,97"

Data Sheet

QUALITY IN DETAIL

INDOOR SERIES

CR-IR 2 PRO "P2,97" | CR-IR 2 PLUS "P2,97"





02-03	○ Series and Features
04-05	○ Product Details
06-07	○ Size - Product Photo
08-09	○ Cabinet Detail - Safety
10-11	○ Installation Guides
12-13	○ Accessories - Company Info

- Advanced High Brightness Black technology,
- Advanced High Refresh Rate,
- Fast installation of panel to Light Frame,
- Just Signal person to install/uninstall, saving labor cost
- Die-Casting Aluminum frame design,
No noise, lower power consumption, good heat dissipation.
- Low Weight and Ultra thin Cabinet

elite

Series



CR-IR 2 PRO "P2,97"

- High Refresh Rate: 3840Hz
- A Class Led Chip
- High Quality PCB
- High Quality MASK

CR-IR 2 PLUS "P2,97"

- High end Refresh Rate: 3840Hz
- A Class Led Chip
- Best Quality PCB
- Best Quality MASK
- High end Refresh Rate
- 14-18 Bit
- Clear View
- Free Rotation
- HDR
- 4K Refresh Rate

FEATURES



Features

- *** FRONT SERVICE
- *** Light Weight
- *** Aliminum Die-Casting
- *** 500x500 : 12 in 1 Case weight with products: 118kg.
- *** Advenced and safety Lock
- *** Nova Star Controller
- *** SPACE BLACK
- *** Flat or Curver Series " optional "

○ TECHNICAL SPECIFICATION

MODEL NAME	CR-IR 3 PRO P3,91	CR-IR 3 PLUS P3,91
Features	:	:
Series	Pro	Plus
Panel installation type	Rental	Rental
Operating Environment	Indoor	Indoor
Pixel Pitch	3,91mm	3,91mm
Brightness	>1100 Nits	>1200 Nits
Refresh Rate	>3840Hz	>3840Hz
Weight / m2	<28	<28
Material Brands		
Lamp	Class A	Class A
Entegred	Chipone or Smilar	Chipone or Smilar
Powersupply	Meanwell or Smilar	Meanwell or Smilar
Controller	Novastar	Novastar
Connectors : Seetronic	Seetronic	Seetronic
Module Specifications	:	:
Pixel Configuration	SMD 2020	SMD 2020
LED Chip	Cooper	Cooper
LED	Space Black	Space Black
Module Size (mm)	250mm x 250mm	250mm x 250mm
Module Resolution	64 x 64	64 x 64
Processing	>14-16 Bit	>14-18 Bit
PCB Quality	Best Quality	Best Quality
Module - Mask Quality	Normal Mask	Normal Mask
Picture / Video Quality	High Quality	Best Quality
Grey Scale	>65536	>262144
Cabinet Specifications	:	:
Module Per Cabinet	4 MODULE	4 MODULE
Cabinet Size (mm)	500 x 500 x 85	500 x 500 x 85
Cabinet Material	Die-Casting Aliminum	Die-Casting Aliminum
Weight Per Panel Net kg.	7	7
Cabinet Resolution	128x128	128x128
Pixel Density / Cabinet	16384	16384
IP Rating	IP40	IP40
Others Specifications	:	:
Driving IC Type	PWM	PWM
Refrate Quality 2	High Refresh Rate	Highend Refresh Rate
No Waterless Ripple of Camera	>%75	>%90
Driving Method " Scan "	1/16	1/16
Resolution/SQM	256 x 256	256 x 256
Pixel Density / m2	65536	65536
White Color Calibration (Adj.)	3.500K~8.500K	3.500K~8.500K
Horizontal Viewing Angle	140 (±30)	140 (±30)
Vertical Viewing Angle	140 (±30)	140 (±30)
Low Latency	No	Yes
HDR	No	Yes
Mapping	No	Yes
Rotation per 90 Degree	Yes	Yes
Free Rotation (with R5)	Optional	Yes
Clear View	Optional	Yes
Refresh Quality	High Quality	Best Quality
High Refresh (PLL inside)	-	Yes
High Refresh Power Saving	Yes	Yes
High Refresh Dynamic Power Saving	-	Yes
Expected LED Lifetime %50	>100.000 Hours	>100.000 Hours
Operating Temperature Range	-15 - +45 (±10)	-15 - +45 (±10)
Operating Humidity Range	-40! " +60! ,10%-90%RH	-40! " +60! ,10%-90%RH
Power on Time (<w/sqm)	800	800
Power Consumption (<w/sqm)	500	500
Average Power Consumption (<w/sqm)	175	175
Voltage Range	47 ~ 63Hz / 110 ~ 240 VAC	47 ~ 63Hz / 110 ~ 240 VAC
Version	REV21	REV21
Packing include	Plate-Power-Cat5 Cable	Plate-Power-Cat5 Cable
Usage Area	Rental Screen	Rental Screen
Certificate	CE/EMC/LVD-ATR-EUR1 ISO-9001:2015 ISO-14001:2015	CE/EMC/LVD-ATR-EUR1 ISO-9001:2015 ISO-14001:2015

Ava Group GMBH reserves the right to change any product specification, discontinue of any product or services without prior notice

QUALITY IN DETAIL

elite Series



PRODUCT CABINET SIZE

size : 500mm



size : 500mm

size : 70mm



QUALITY IN DETAIL

CABINET SIZE

elite

Series



PRODUCT PHOTO

QUALITY IN DETAIL

elite

Series



CABINET DETAIL

Handle

Square Protect In/Out



Power In/Out

Signal In/Out

Lock

Module Lock

RESET BUTTON

Front Service



QUALITY IN DETAIL

SAFETY

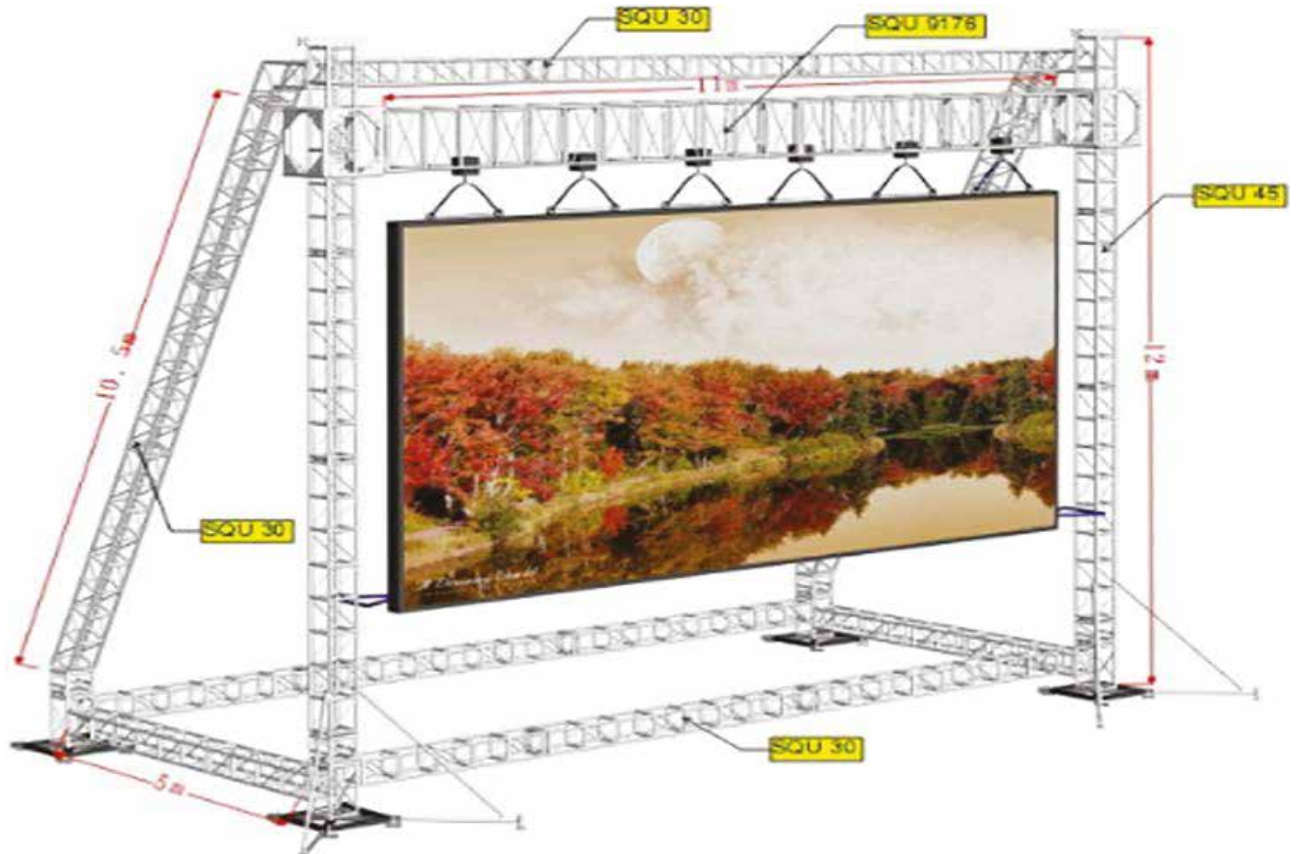

elite Series

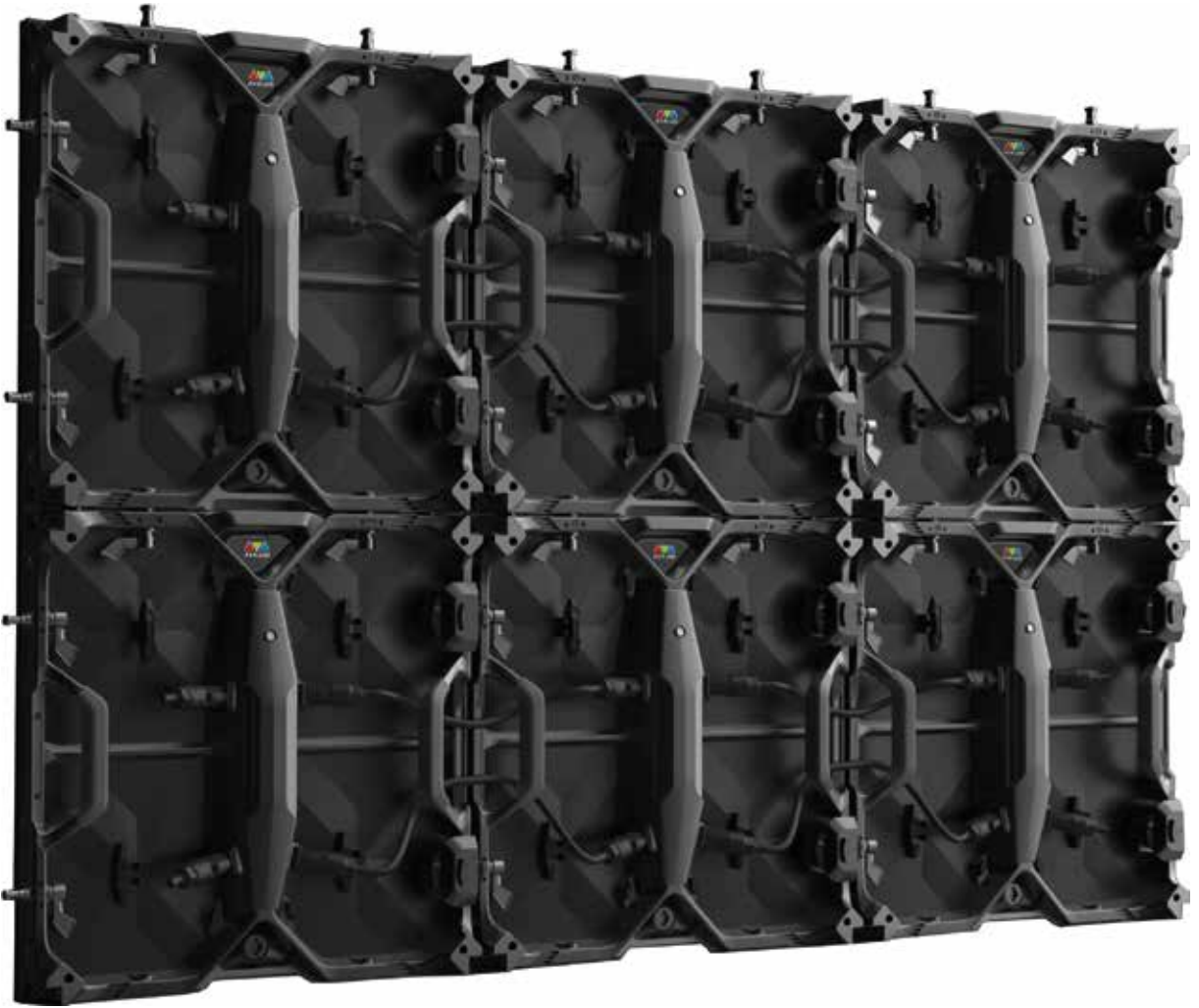

INSTALLATION

QUALITY IN DETAIL

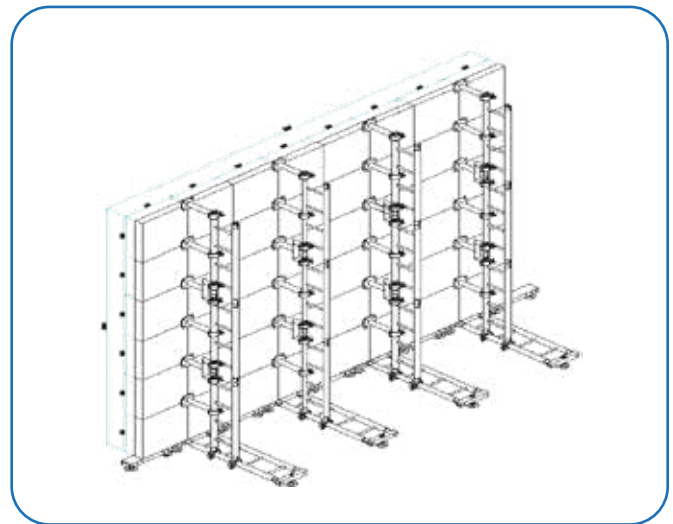

INSTALLATION

elite Series

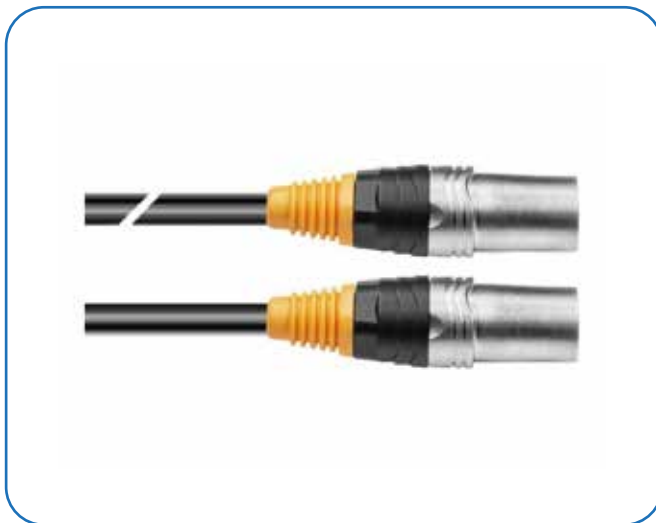

ACCESSORIES



AVA LED

www.avaledscreen.com

info@avaledscreen.com

AVA GROUP GMBH

Adress: Seellbaschstrasse 5 , 66687 Wadern / Germany

Phone : +49 211 730 64 817

