

AKTİF RANZA (AKTİF BUNK)

RANZAYI
FONKSİYONEL OLARAK
HER İKİ ŞEKİLDE DE
MONTAJINI
YAPABİLİRSİNİZ.

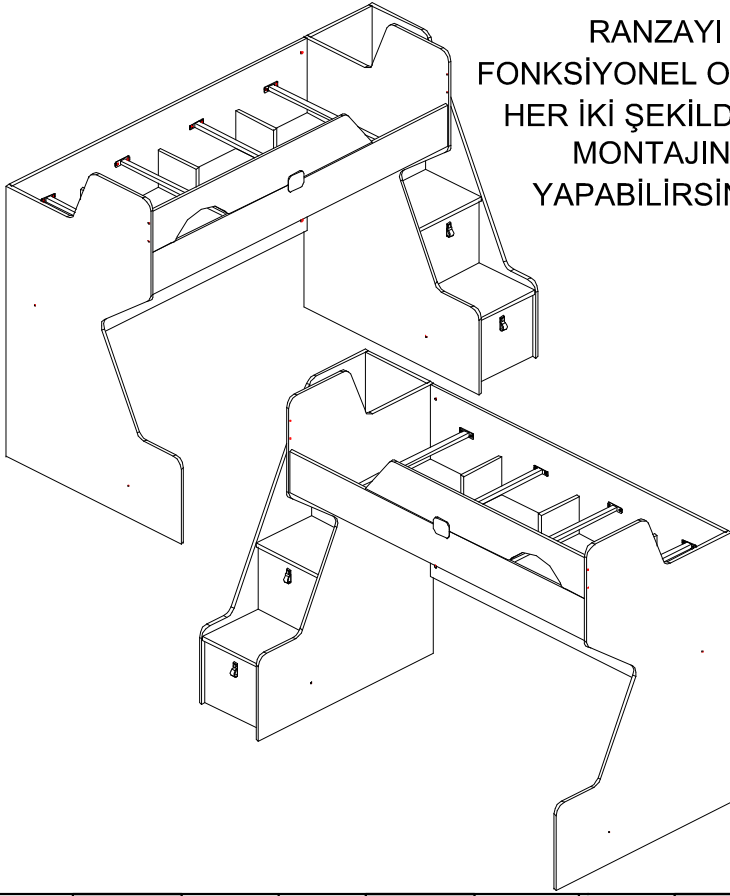

KURULUM 2 KİŞİ İLE
YAPILMALIDIR.

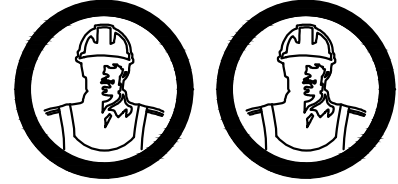

GEREKLİ ARAÇLAR

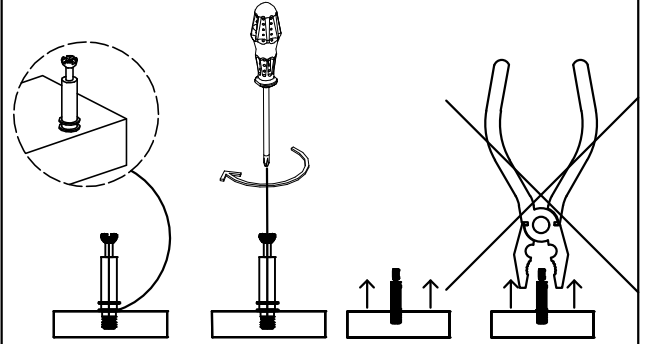

X-01



48 x

X-02

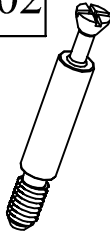

48 x

X-03

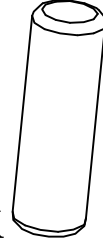

44 x

X-04

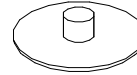

48 x

X-05

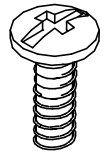

16 x

X-06



2 x

X-07

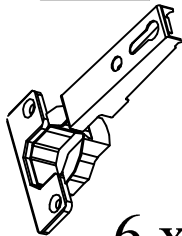

6 x

X-08

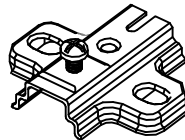

6 x

X-09

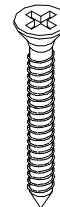
18 x
(4*50)

X-10

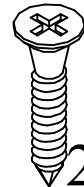
24 x
(3,5x18)

X-11

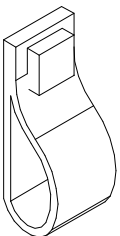

3 x

X-12

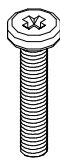
3 x
(M4*25)

X-13

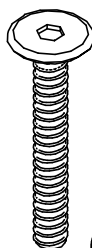
4 x
(M6*50)

X-14

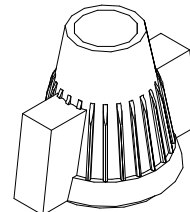

4 x

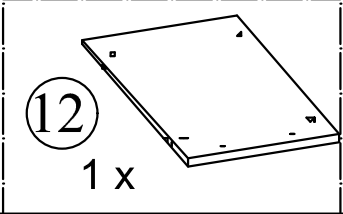
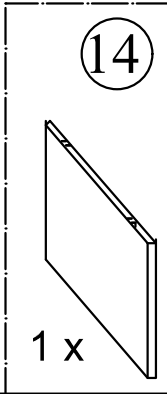
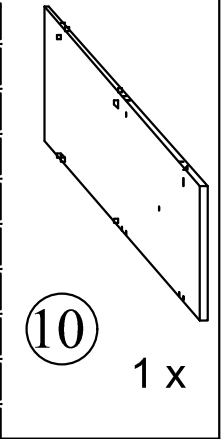
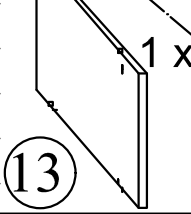
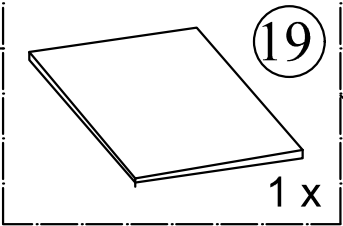
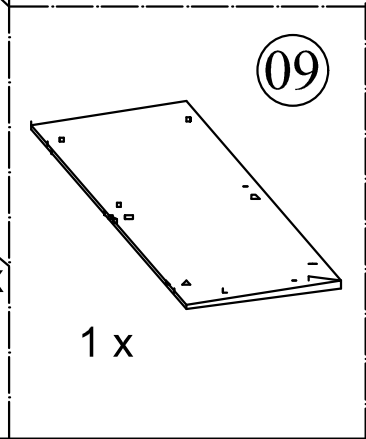
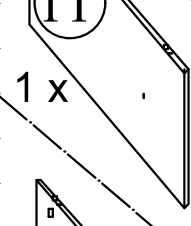
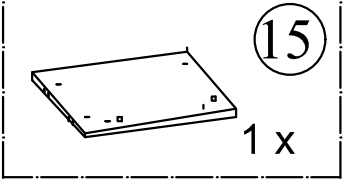
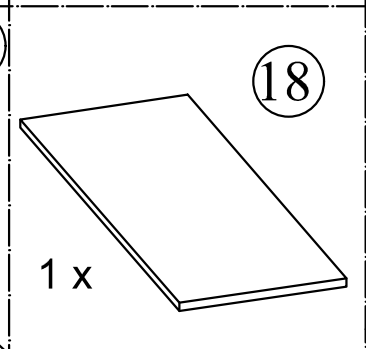
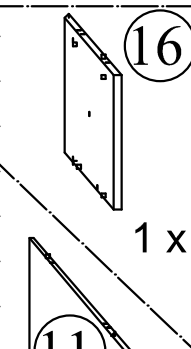
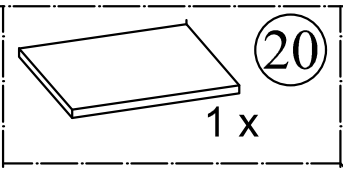
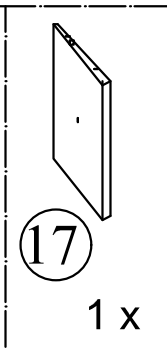
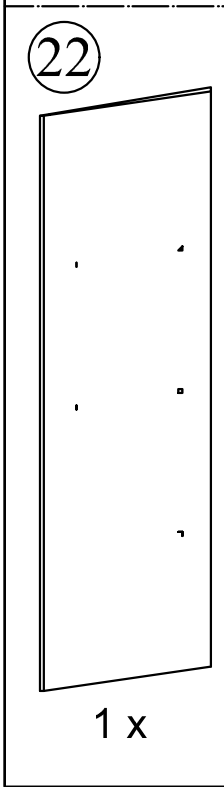
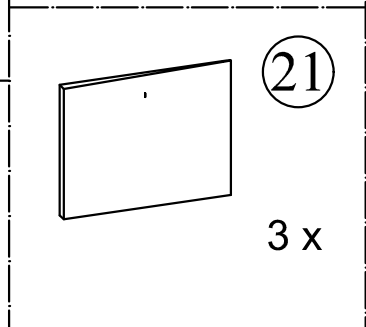
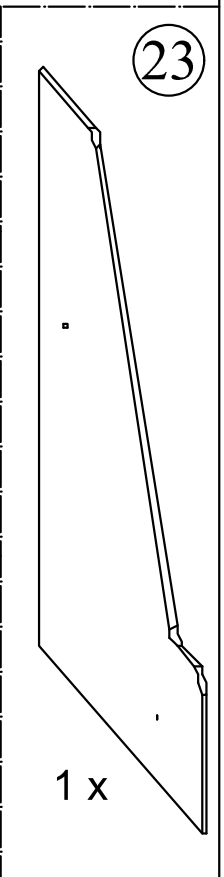
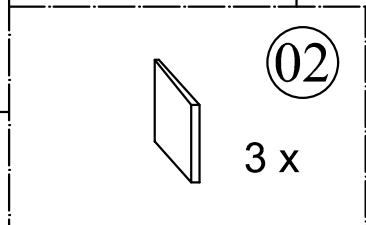
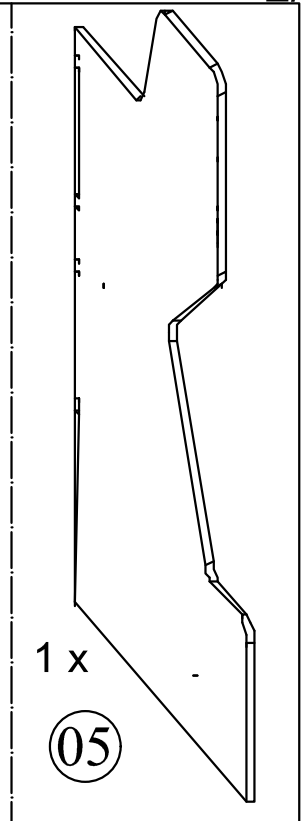
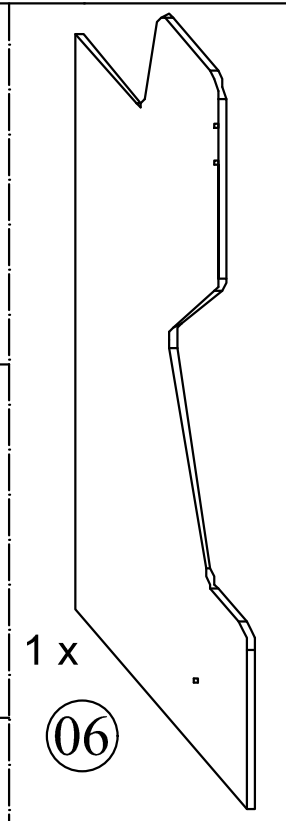
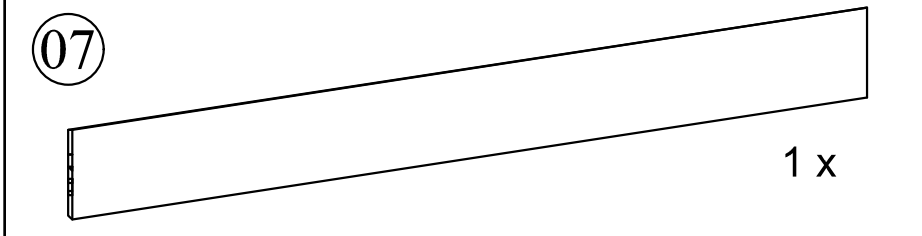
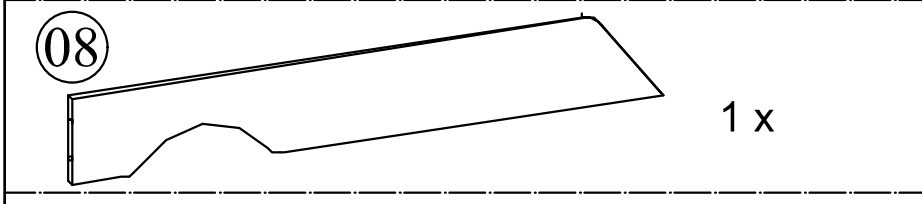
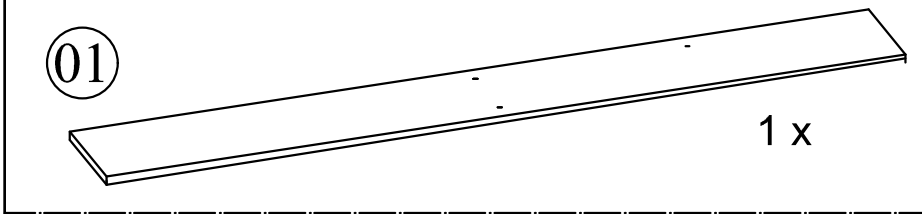
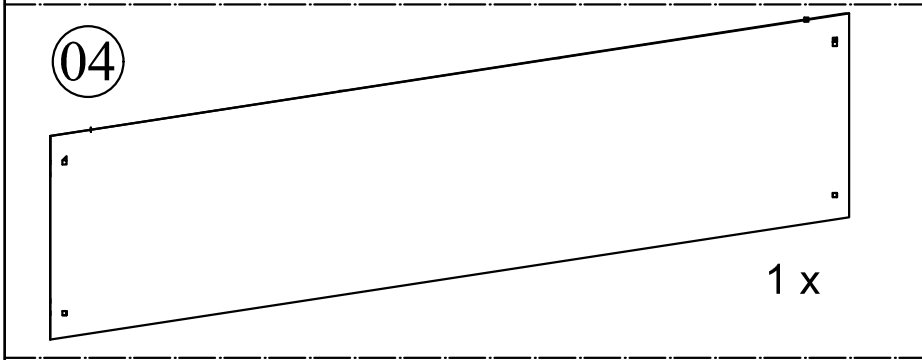
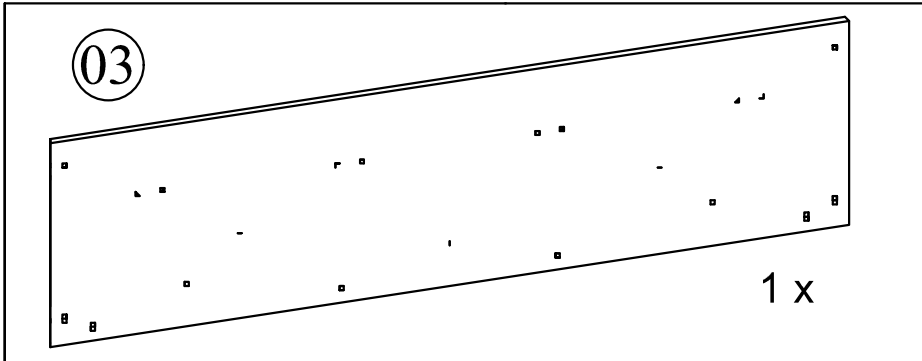

DİKKAT!
(ATTENTION!)

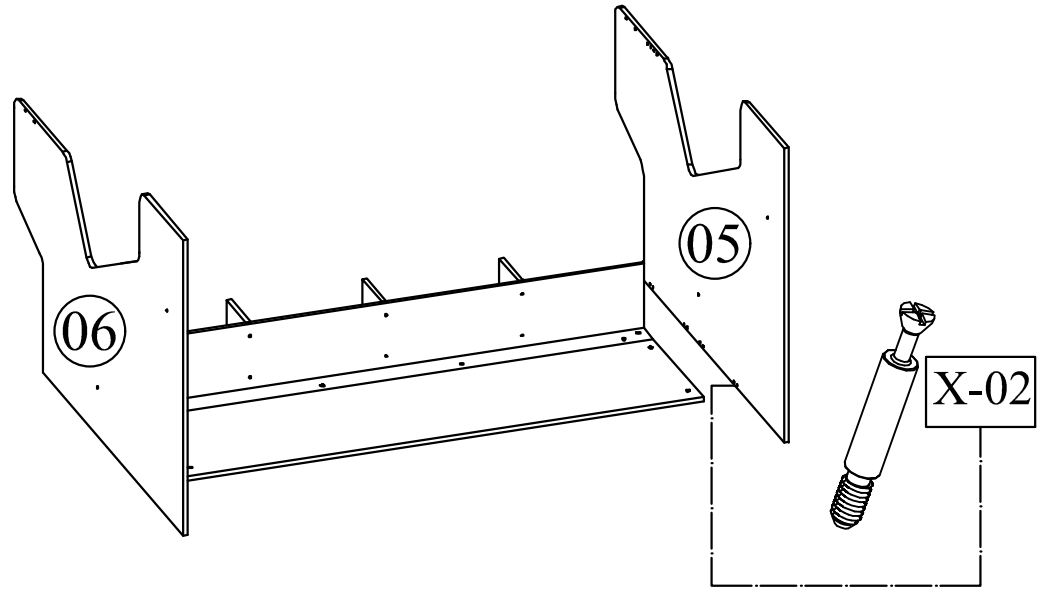
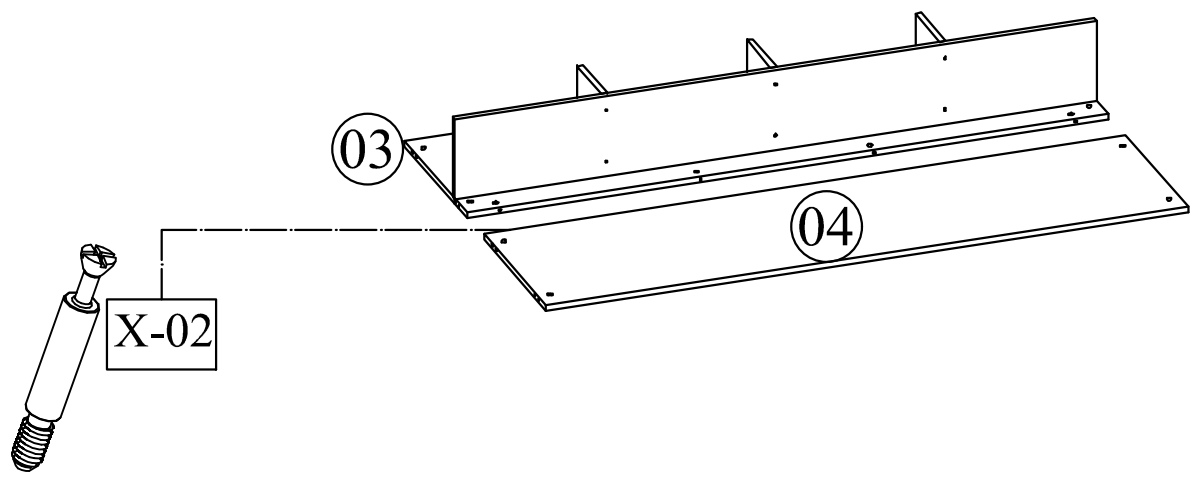
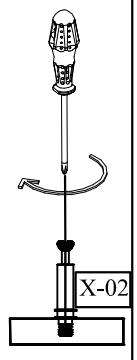
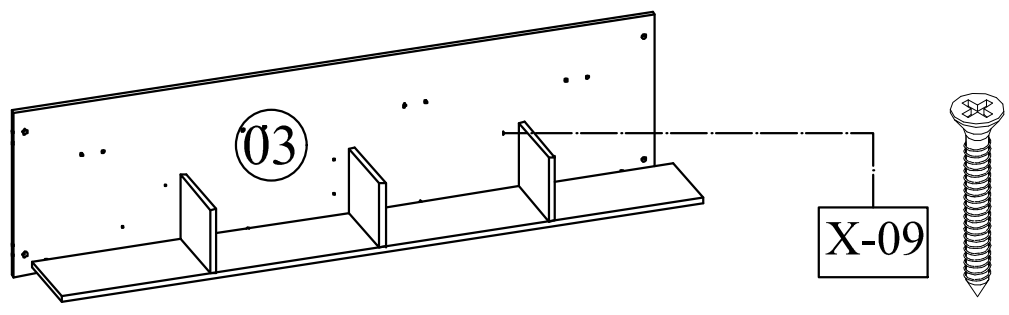
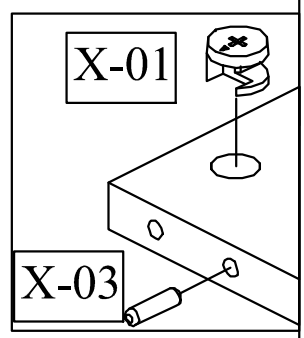
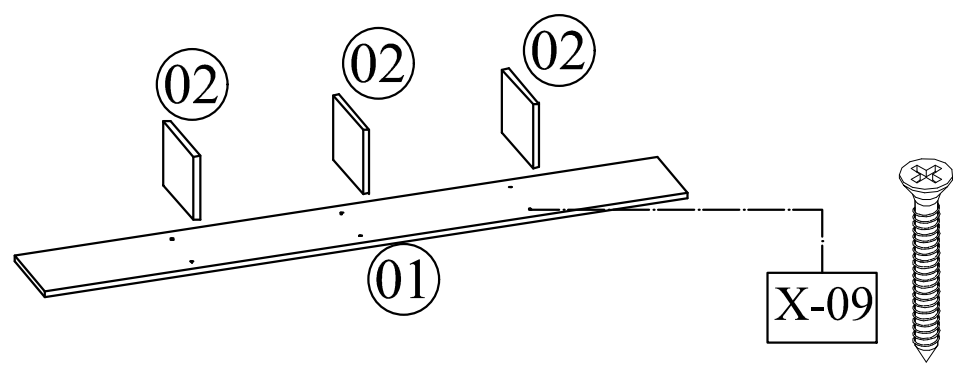

**DİKKAT !
(ATTENTION !)**

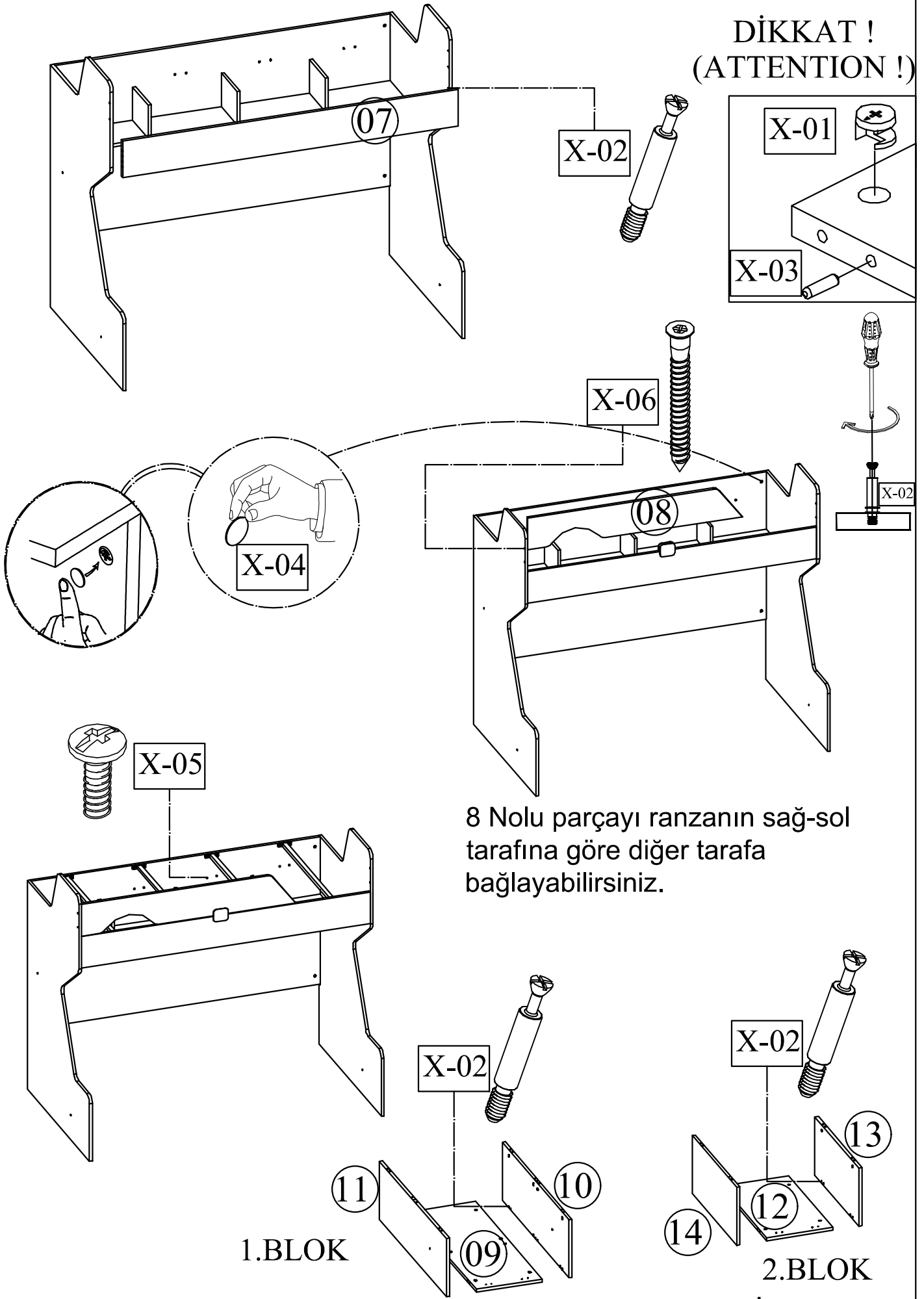

8 Nolu parçayı ranzanın sağ-sol tarafına göre diğer tarafa bağlayabilirsiniz.

1.BLOK

2.BLOK

Merdiven montajında iz delikli parçaların alt tabla olarak kullanınız. İz deliklerini alt tablanın üst yüzüne gelecek şekilde dikkat ederek montajını sorunsuz bir şekilde yapabilirsiniz.

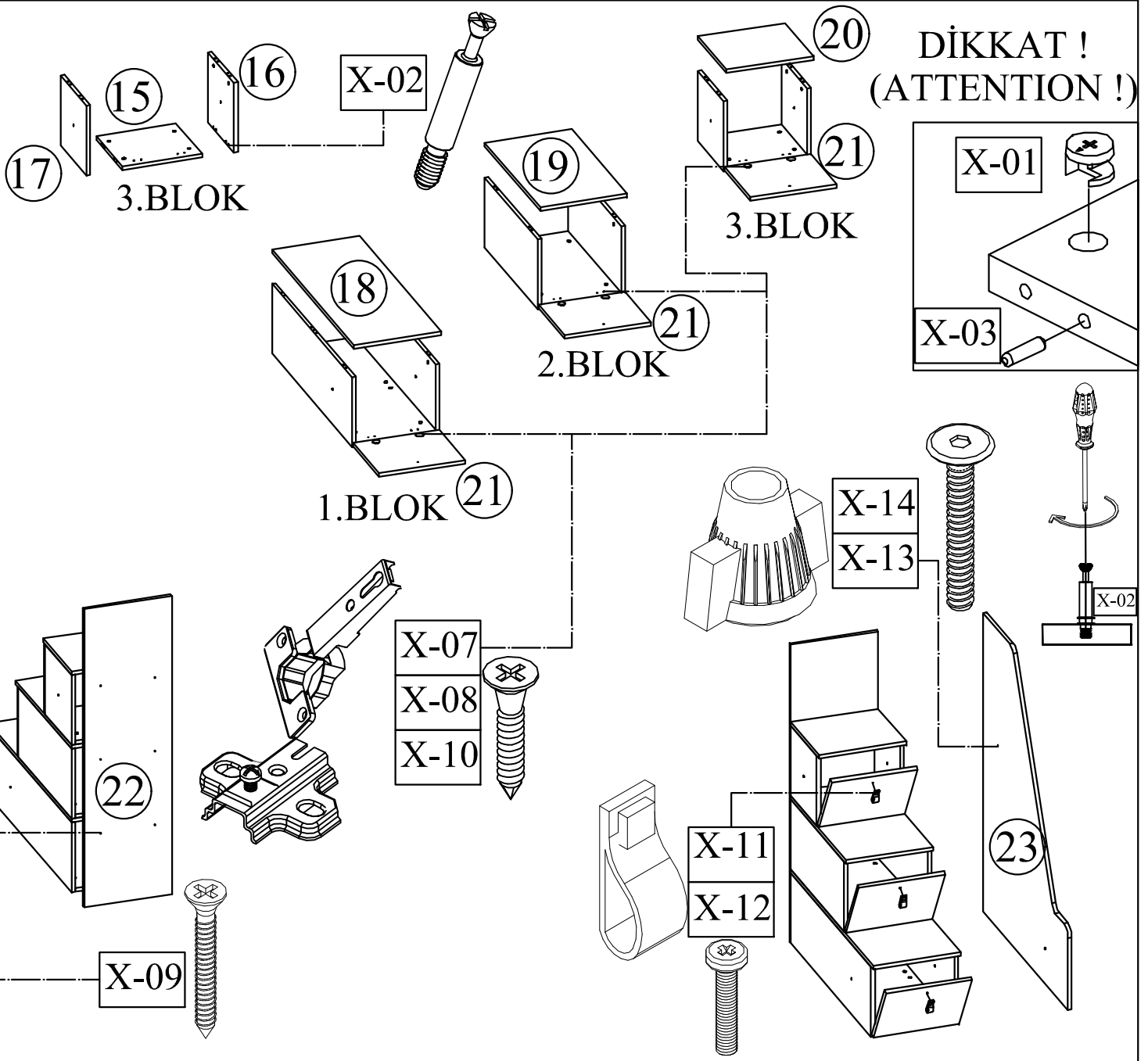

23 Nolu parçayı merdiveni ranzanın sağ-sol tarafına göre diğer tarafa bağlayabilirsiniz.

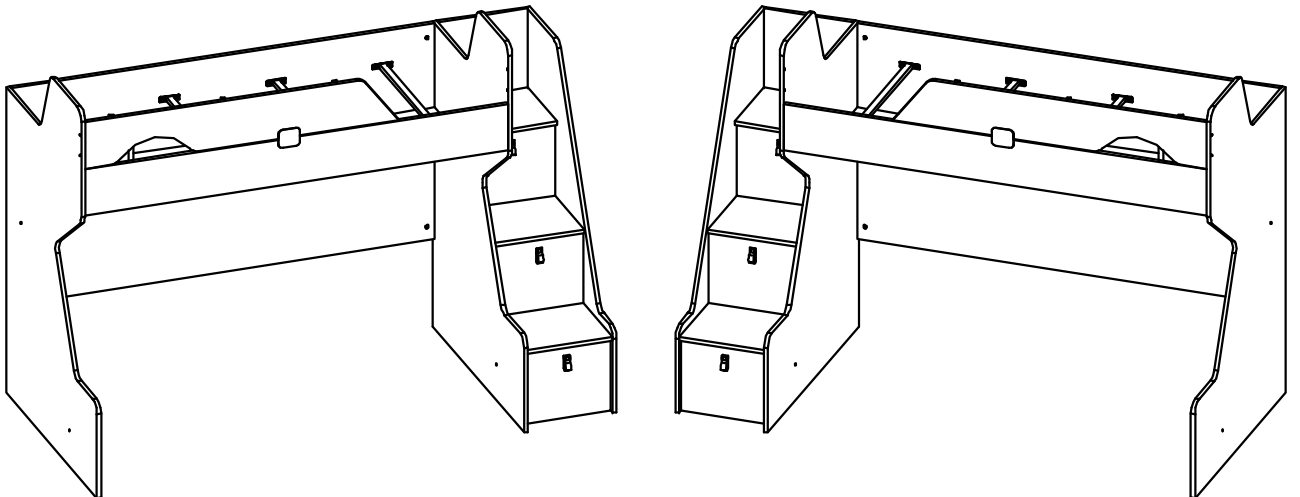



AKTİF DOLAP

(AKTİF WERDROBE)

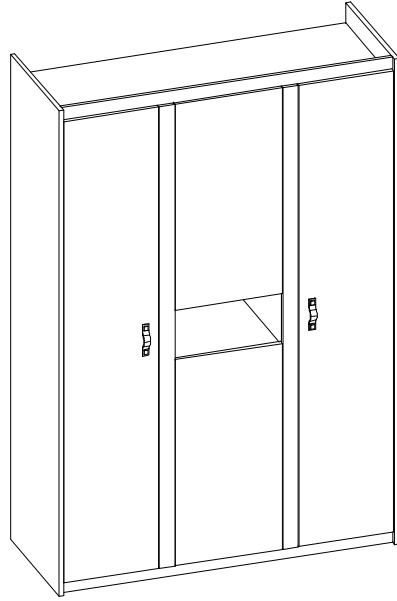
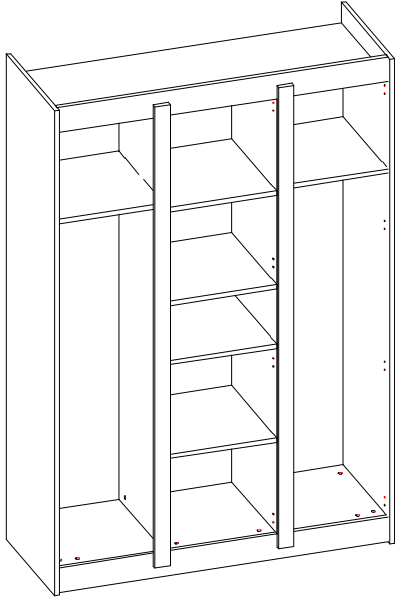

KURULUM 2 KİŞİ İLE
YAPILMALIDIR.



GEREKLİ ARAÇLAR

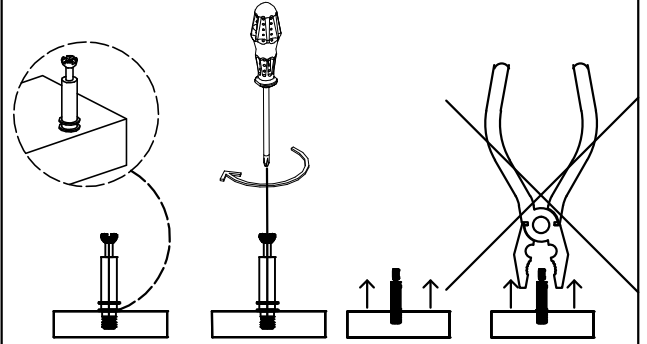
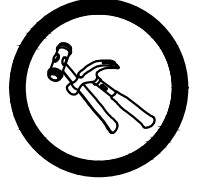
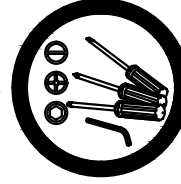
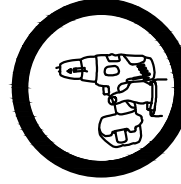

X-01



36 x

X-02

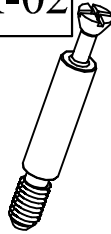

36 x

X-03



36 x

X-04

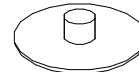

36 x

X-05

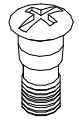

24 x

X-06

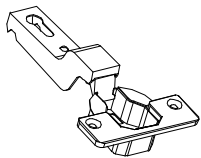

12 x

X-07

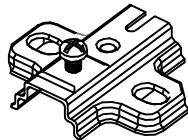

12 x

X-08

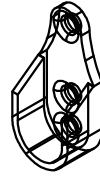

4 x

X-09



2 x

X-10

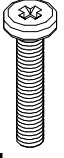

4 x
(M4*22)

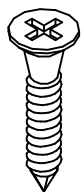

X-11

48 x
(3,5x18)

X-12

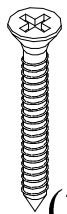

30 x
(3,5*25)

X-13

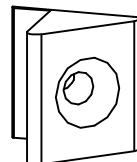

10 x

01

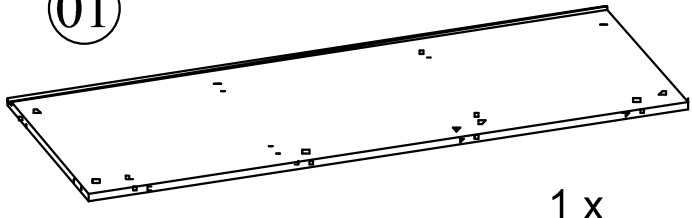

1 x

02

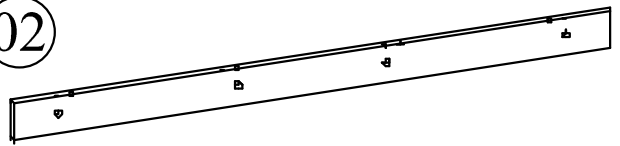

1 x

04

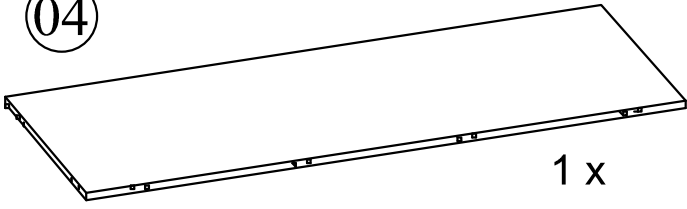

1 x

03

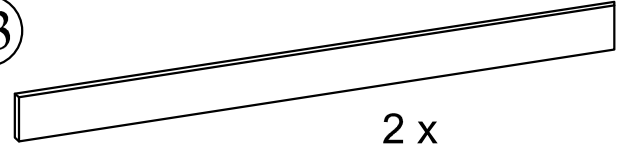

2 x

09

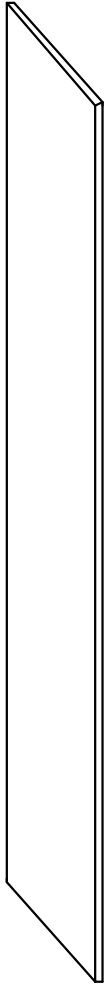

1 x

08

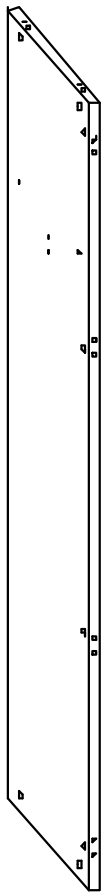

1 x

06

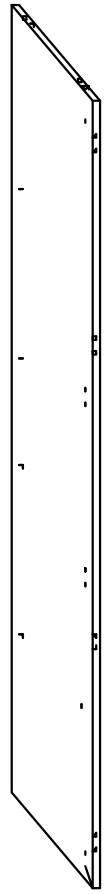

1 x

05

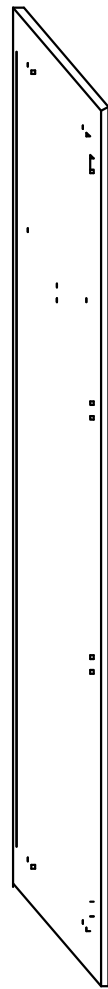

1 x

10



2 x

14

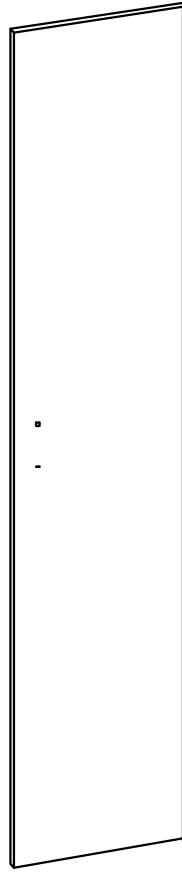

2 x

15

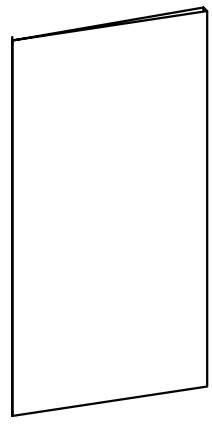

2 x

12

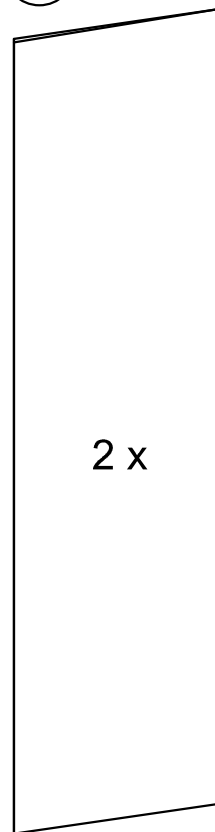

2 x

13

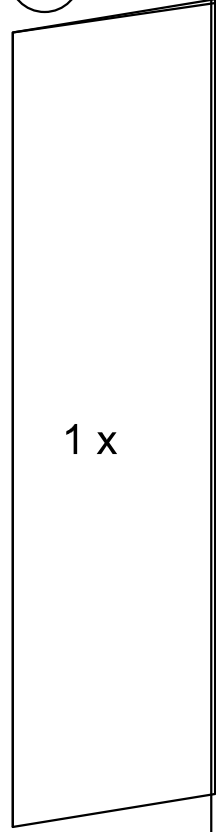

1 x

07

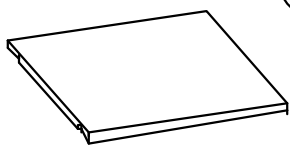

2 x

11

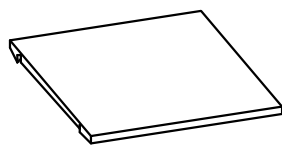

4 x

**DİKKAT !
(ATTENTION !)**

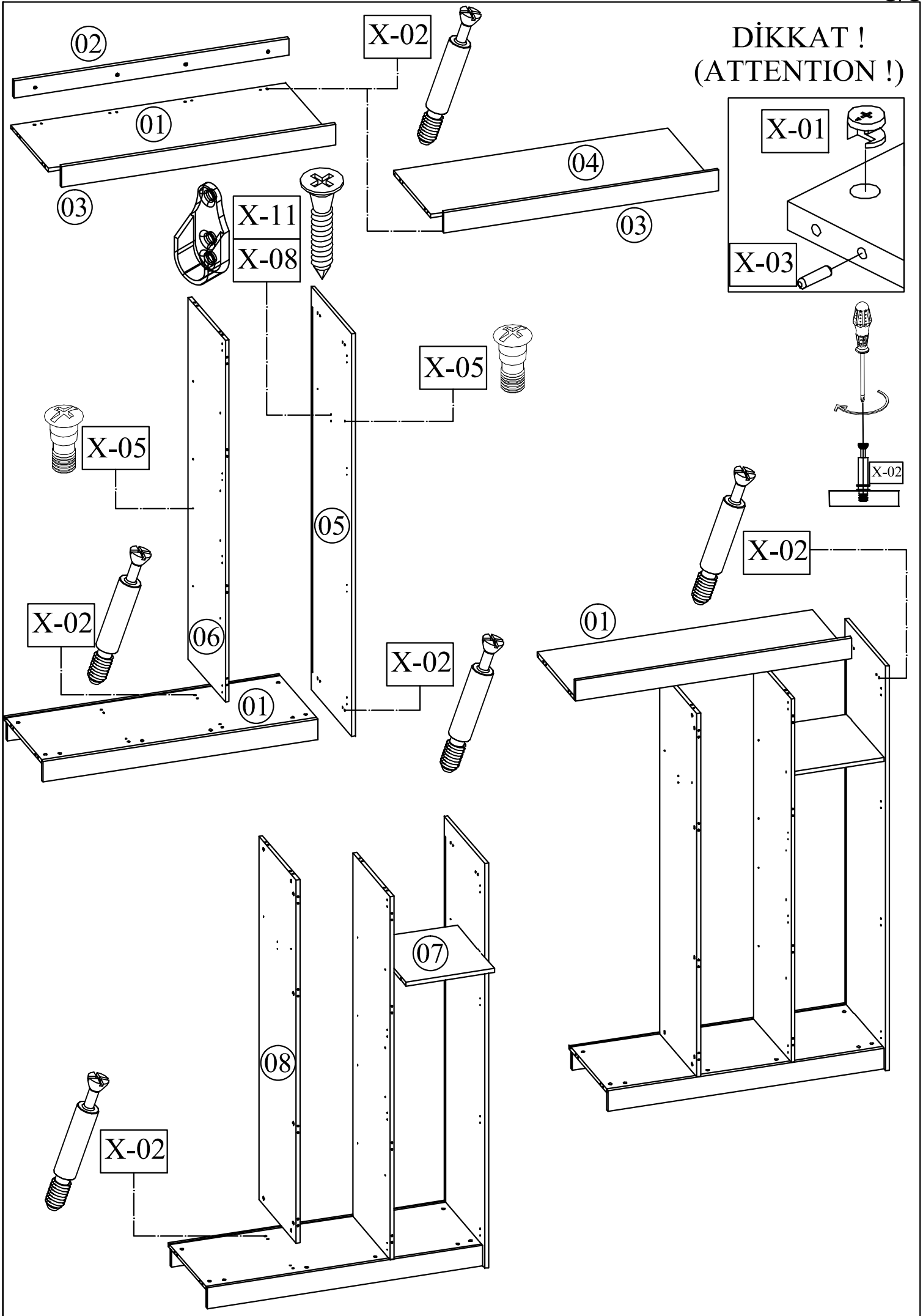

DİKKAT !
(ATTENTION !)

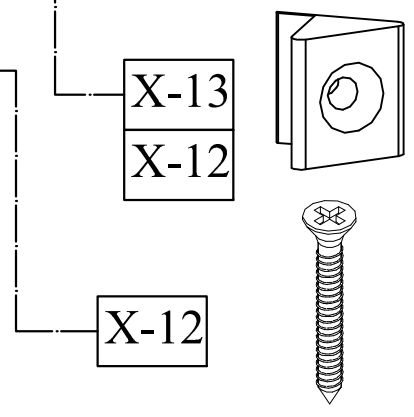
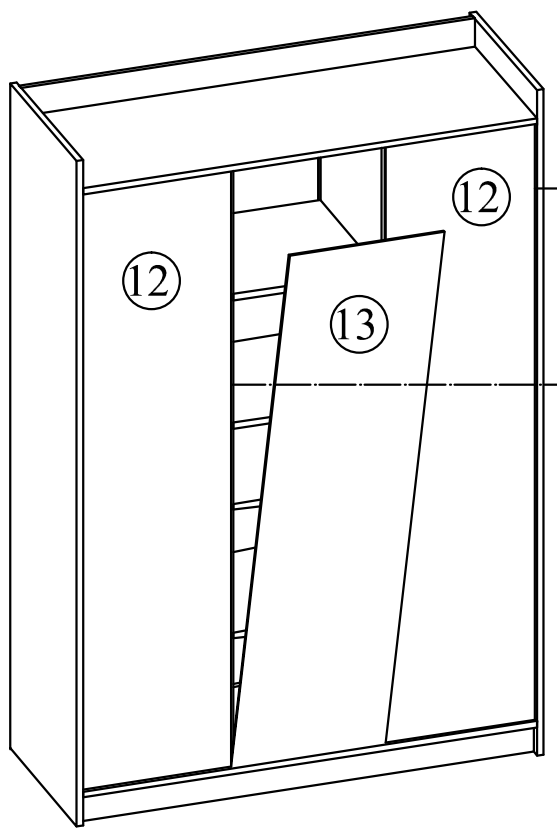
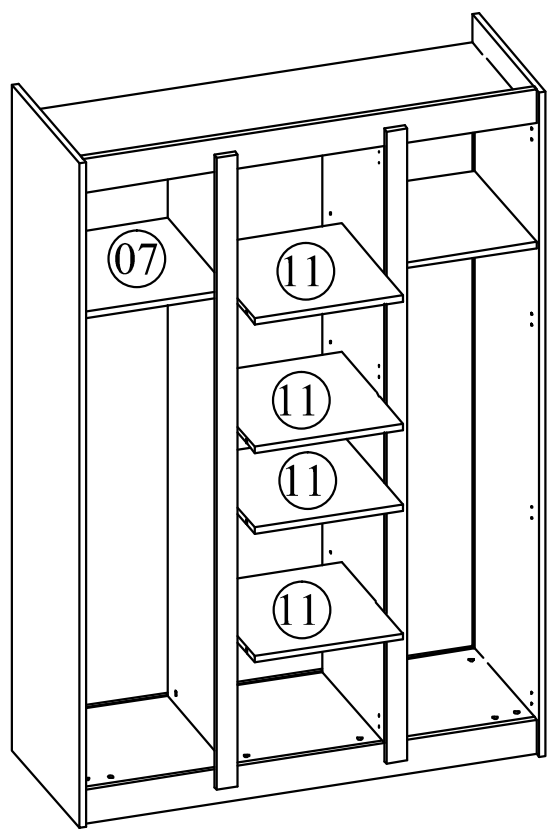
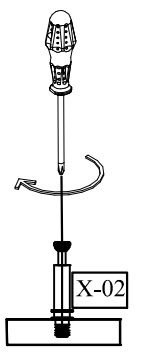
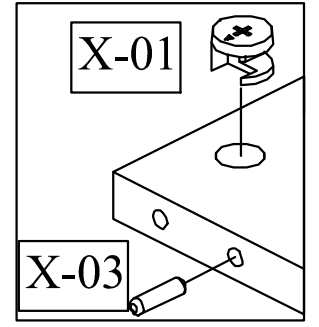
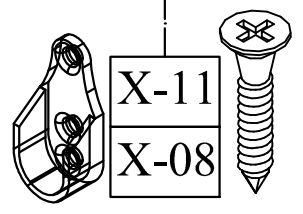
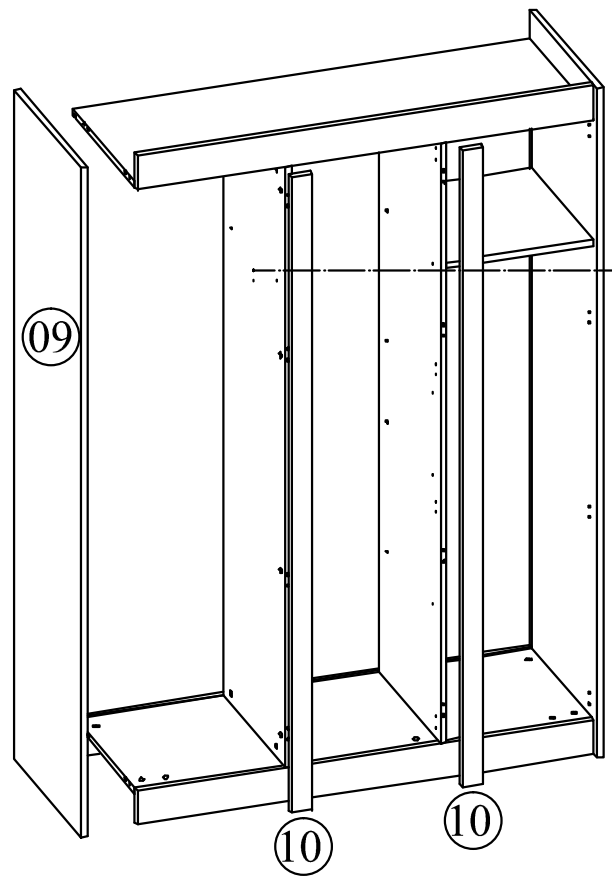

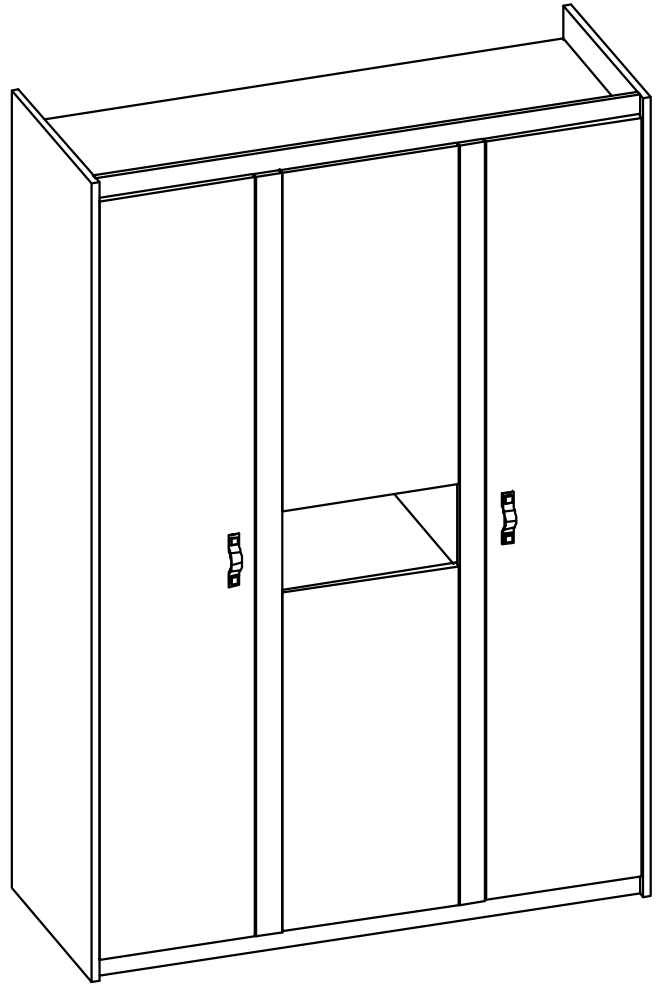
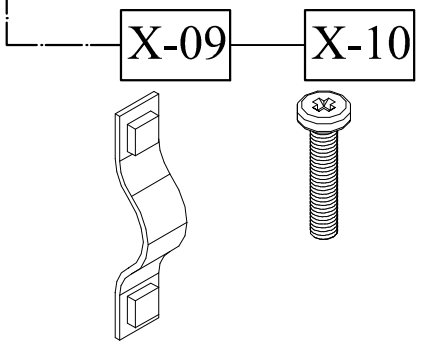
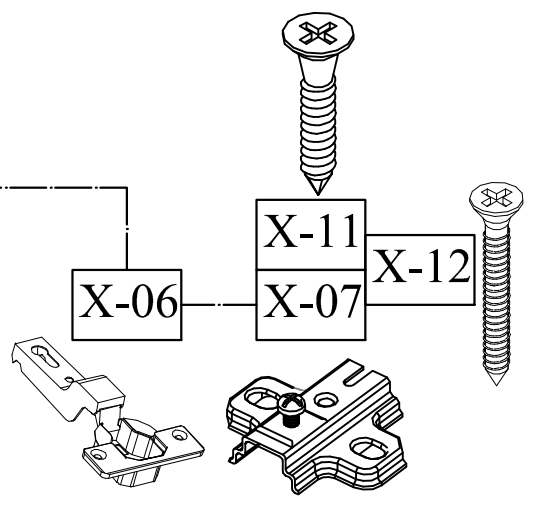
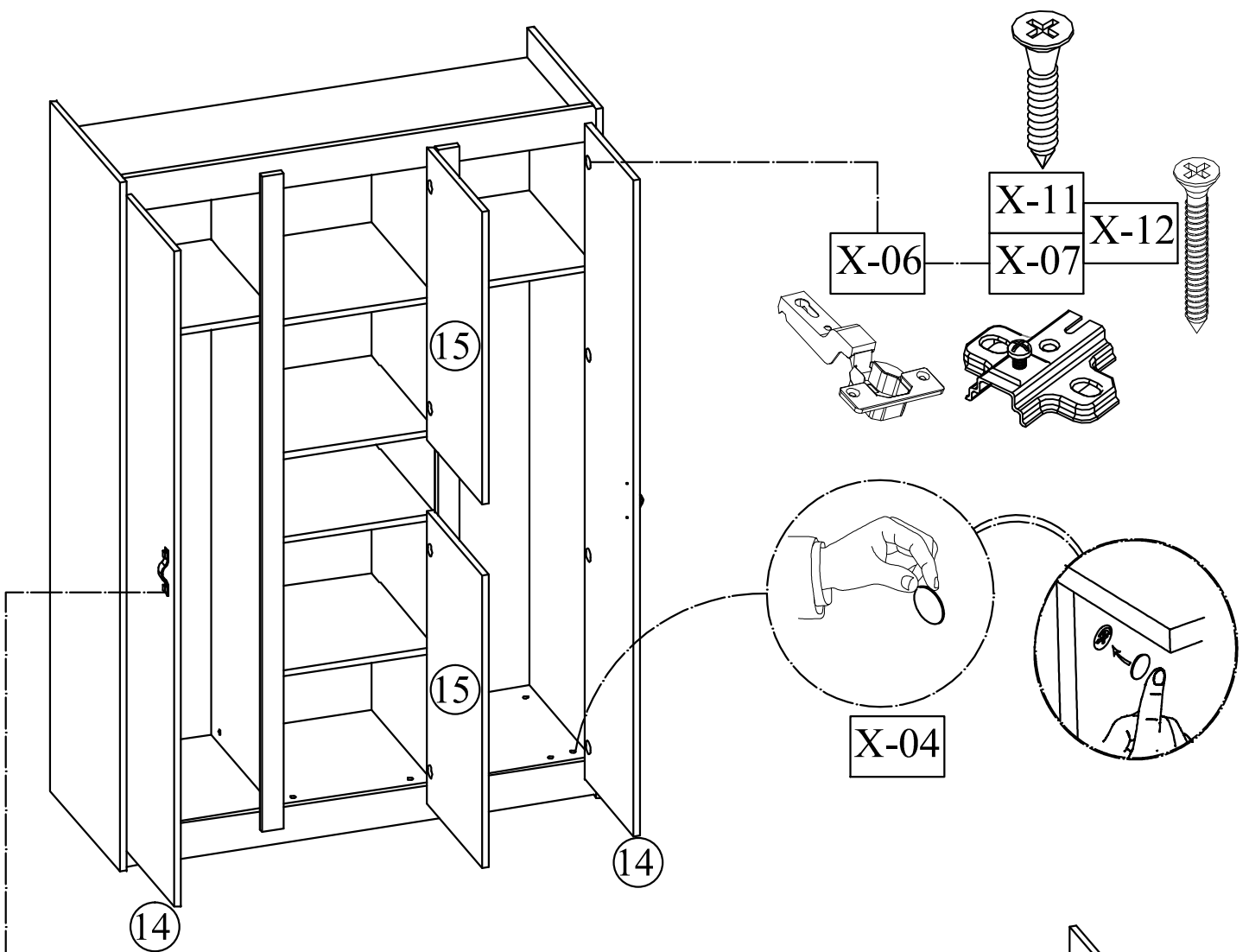

AKTİF KARYOLA (AKTİF BEDSTEAD)

KARYOLAYI
FONKSİYONEL OLARAK
HER İKİ ŞEKİLDE DE
MONTAJINI
YAPABİLİRSİNİZ.

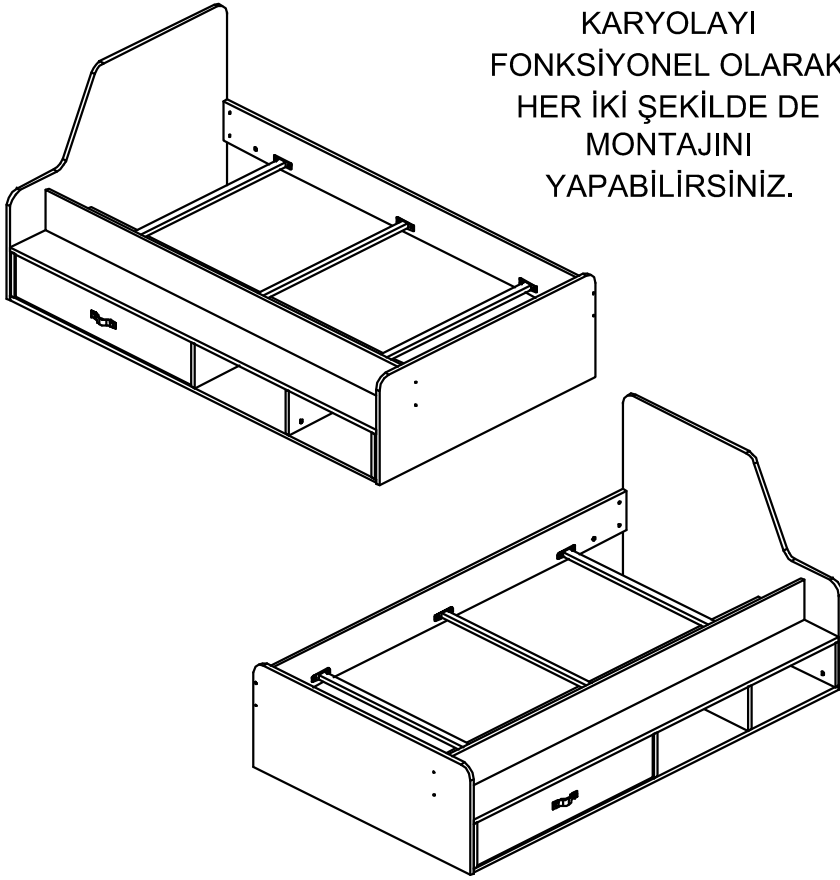

KURULUM 2 KİŞİ İLE
YAPILMALIDIR.

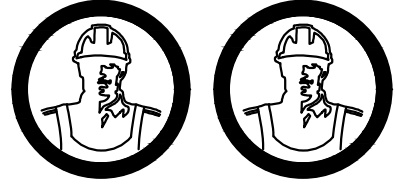

GEREKLİ ARAÇLAR

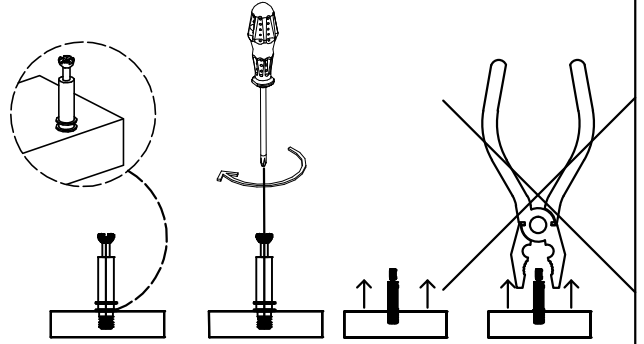

X-01



26 x

X-02

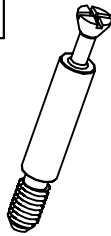

26 x

X-03



18 x

X-04

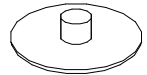

26 x

X-05

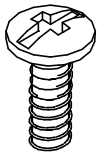

12 x

X-06

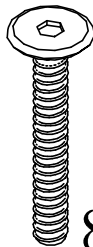

8 x

X-07



8 x

X-08

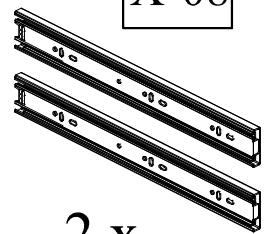

2 x

X-09

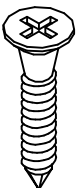
8 x
(3,5x18)

X-10

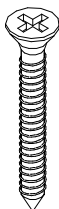
3 x
(3,5*25)

X-11



1 x

X-12

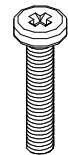
2 x
(M4*22)

05

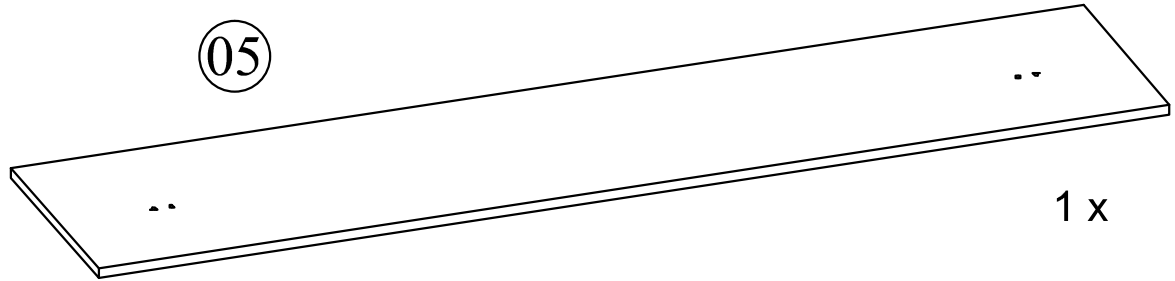

1 x

04

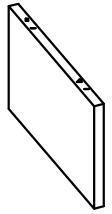

1 x

03

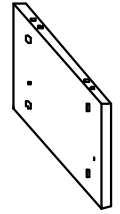

1 x

02

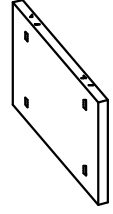

2 x

01

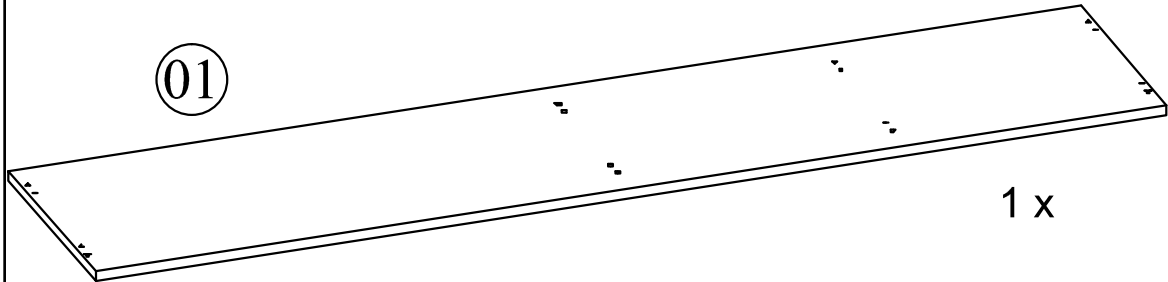

1 x

07

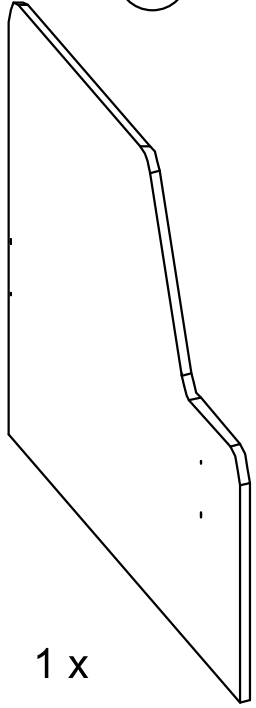

1 x

06

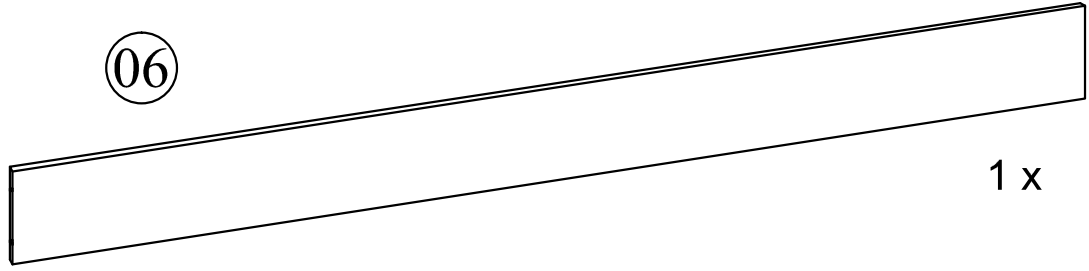

1 x

09

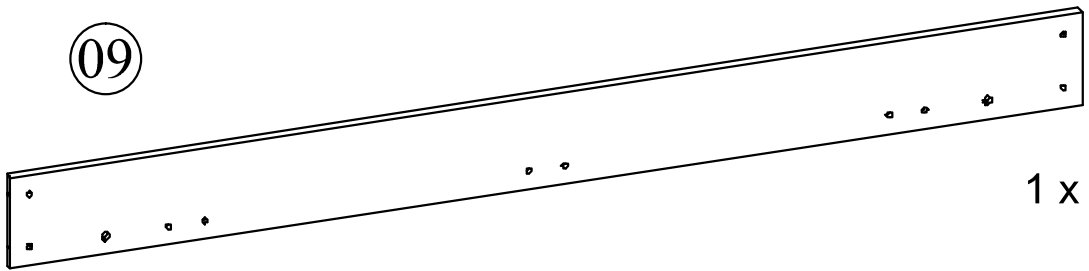

1 x

12

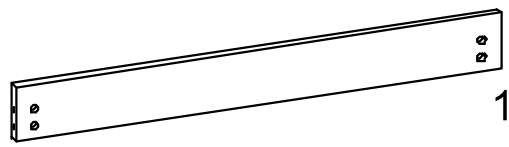

1 x

10

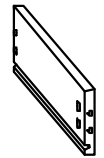

1 x

08

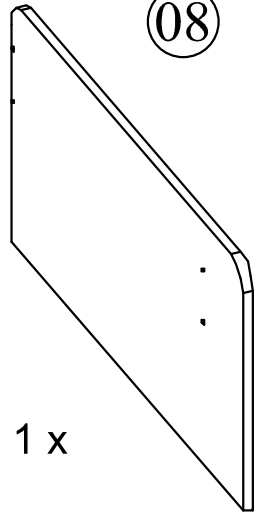

1 x

14

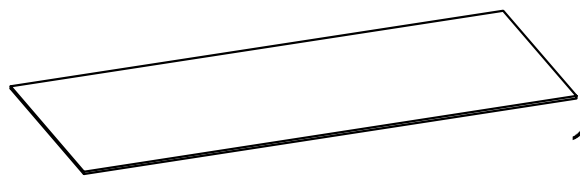

1 x

11

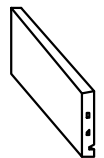

1 x

13

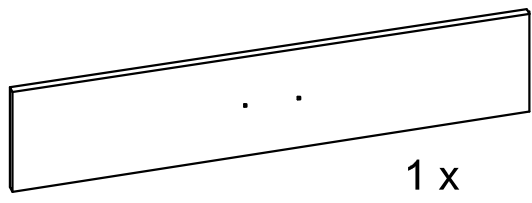

1 x

DİKKAT!
(ATTENTION!)

