



SQN70... / SQN71...



SQN74... / SQN75...



Actuators

SQN7...

for air dampers and control valves of oil or gas burners

Reversible electromotoric actuators with torques up to 2.5 Nm

- **Run times:**
 - SQN70... / SQN71... 4...30 s
 - SQN74... / SQN75... 4...60 s
- **Versions:**
 - Clockwise or counterclockwise rotation
 - With integrated electronic modules
 - Choice of drive shafts
- With 2 end and 2...4 auxiliary switches, some with fine adjustment
- Geartrain can be disengaged
- SQN70... / SQN71... - With adapter for direct replacement of actuators type SQN30... / SQN31...
- SQN74... / SQN75... - Drive shafts, fixing holes and cable entries are matched to the same type of actuator supplied by Conectron or Berger
- Versions with UL listing for use in the U.S. and Canada

The SQN7... and this Data Sheet are intended for use by OEMs which integrate the actuators in their products!

Use

The SQN7... actuators are designed for driving air and gas dampers of oil or gas burners of small to medium capacity and afford load-dependent control of the amount of gas, oil or combustion air

- in connection with single- or 2-wire control, or 3-position controllers, or
- directly via the burner control

Warning notes



To avoid injury to persons, damage to property or the environment, the following warning notes should be observed!

Do not interfere with or modify the actuators!

- Before performing any wiring changes in the connection area of the actuator, completely isolate the equipment from the mains supply (all-polar disconnection)
- Ensure protection against electric shock hazard by providing adequate protection for the terminals and by securing the housing cover
- Check to ensure that wiring is in an orderly state
- Fall or shock can adversely affect the safety functions. Such units may not be put into operation, even if they do not exhibit any damage

Mounting notes

- Ensure that the relevant national safety regulations are complied with

Installation notes

- Installation work must be carried out by qualified staff

Commissioning notes

- Commissioning work must be carried out by qualified staff
- Prior to commissioning, ensure that wiring is in an orderly state

Norms and standards

Conformity to EEC directives

- Electromagnetic compatibility EMC (immunity) 89 / 336 EEC
- Low-voltage directive 73 / 23 EEC

Service notes

- Maintenance work must be carried out by qualified staff
- Each time a unit has been replaced, check to ensure that wiring is in an orderly state

Disposal notes



The actuator contains electrical and electronic components and may not be disposed of together with household waste.
Local and currently valid legislation must be observed.

Mechanical design

Housing	<ul style="list-style-type: none">- Made of impact-proof and heat-resistant plastic <p>Color: SQN70... / SQN71...: Geartrain housing dark-grey, cover light-grey SQN74... / SQN75...: Completely black</p>
Drive motor	<ul style="list-style-type: none">- Reversible and locking-proof synchronous motor
Coupling	<ul style="list-style-type: none">- Drive shaft can be manually disengaged from geartrain and motor- Automatic reengagement
Adjustment of switching points	<ul style="list-style-type: none">- By means of adjustable cams- Scales beside the cams indicate the angle of the switching point- Assignment of cams to the end and auxiliary switches is color-coded (refer to «Connection diagrams»)- Some of the cam switches feature fine adjustment; they can be changed with a standard screwdriver- The other cams can be adjusted manually or with the enclosed hook-spanner or similar tool
Position indication	<ul style="list-style-type: none">- Internally: Scale at the beginning of the camshaft on the geartrain side
Electrical connections	<ul style="list-style-type: none">- Screw terminals
Geartrain	<ul style="list-style-type: none">- Maintenance-free
Drive shaft	<ul style="list-style-type: none">- Made of black-finished steel- Ready fitted to the front of the geartrain- Different versions available
Mounting and fixing	<ul style="list-style-type: none">- Front of the geartrain is used as the mounting surface- Actuator is secured via through-holes
Printed circuit boards	<ul style="list-style-type: none">- Made of glass-fiber reinforced epoxy resin- Metalized through-holes

Type summary

Actuators SQN70... / counterclockwise rotation ⁹⁾

Diagram no.	Drive shaft ¹⁾ no.	Run time at 50 Hz ²⁾ for 90° s	Nominal torque ⁶⁾ Nm	Holding torque Nm	AS ¹⁰⁾ pcs.	Relays ¹¹⁾ pcs.	Length of housing ¹⁾ mm	AC 230 V ³⁾ +10 % -15 % 50...60 Hz Type reference ⁸⁾	AC 110 V ⁴⁾ +10 % -15 % 50...60 Hz Type reference	SQN7... replaces Type reference ⁷⁾
2	0	4	1.5	0.7	2	2	117	SQN70.224A20	---	---
4	0	4	1.5	0.7	2	3	117	SQN70.244A20	---	SQN30.121A2700
6	0	4	1.5	0.7	2	---	80	SQN70.264A20	---	SQN30.101A2700
9	0	4	1.5	0.7	2	1	117	SQN70.294A20	---	SQN30.111A2700
2	0	6	1.5	0.7	2	2	117	SQN70.324A20	---	SQN30.151A2700
2	0	12	2.5	1.2	2	2	117	SQN70.424A20	---	---
5	0	12	2.5	1.2	2	3	117	SQN70.454A20	---	---
6	0	12	2.5	1.2	2	---	80	SQN70.464A20	---	---
6	3	12	2.5	1.2	4	---	80	SQN70.464A23	---	---
2	0	30	2.5	1.3	2	2	117	SQN70.624A20	---	---
6	3	30	2.5	1.3	2	---	80	SQN70.664A23	---	SQN30.401A2730

Actuators SQN71... / clockwise rotation ⁹⁾

Diagram no.	Drive shaft ¹⁾ no.	Run time at 50 Hz ²⁾ for 90° s	Nominal torque ⁶⁾ Nm	Holding torque Nm	AS ¹⁰⁾ pcs.	Relays ¹¹⁾ pcs.	Length of housing ¹⁾ mm	AC 230 V ³⁾ +10 % -15 % 50...60 Hz Type reference ⁸⁾	AC 110 V ⁴⁾ +10 % -15 % 50...60 Hz Type reference	SQN7... replaces Type reference ⁷⁾
2	0	4	1.5	0.7	2	2	117	SQN71.224A20	---	SQN31.151A2700
6	0	4	1.5	0.7	2	---	80	SQN71.264A20	---	SQN31.101A2700
2	0	12	2.5	1.2	2	2	117	SQN71.424A20	---	---
6	0	30	2.5	1.3	2	---	80	SQN71.664A20	---	SQN31.401A2700

Actuators SQN74... / counterclockwise rotation ⁹⁾

Diagram no.	Drive shaft ¹⁾ no.	Run time at 50 Hz ²⁾ for 90° s	Nominal torque ⁶⁾ Nm	Holding torque Nm	AS ¹⁰⁾ pcs.	Relays ¹¹⁾ pcs.	AC 230 V ³⁾ +10 % -15 % 50...60 Hz Type reference ⁸⁾	AC 110 V ⁴⁾ +10 % -15 % 50...60 Hz Type reference
9	1	4	1.5	0.7	2	1	SQN74.294A21	---

Actuators SQN75... / clockwise rotation ⁹⁾

Diagram no.	Drive shaft ¹⁾ no.	Run time at 50 Hz ²⁾ for 90° s	Nominal torque ⁶⁾ Nm	Holding torque Nm	AS ¹⁰⁾ pcs.	Relays ¹¹⁾ pcs.	AC 230 V ³⁾ +10 % -15 % 50...60 Hz Type reference ⁸⁾	AC 110 V ⁴⁾ +10 % -15 % 50...60 Hz Type reference
2	1	4	1.5	0.7	2	2	SQN75.224A21	---
2	6	4	1.5	0.7	4	2	SQN75.224A26	---
4	1	4	1.5	0.7	2	3	SQN75.244A21	---
4	6	4	1.5	0.7	4	3	SQN75.244A26	---
9	1	4	1.5	0.7	2	1	SQN75.294A21	---
9	1	4	1.5	0.7	4	1	SQN75.294A26	---
F	1	4	1.5	0.7	4	3	SQN75.2F6A21	---
2	1	12	2.5	1.2	2	2	SQN75.424A21	---
2	6	23	2.5	1.2	4	2	SQN75.524A26	---
K	1	30	2.5	1.3	2	---	SQN75.6K4A21	SQN75.6K4A11
6	3	30	2.5	1.3	4	---	SQN75.664A26	---
9	1	30	2.5	1.3	2	1	SQN75.694A21	---

Legend to
«Type summary»

- 1) Refer to «Dimensions»
- 2) At 60 Hz, run times are about 20 % shorter
- 3) AC 220...240 V +10 % / -15 % possible, but in the case of undervoltage torque is reduced by about 20 %
- 4) AC 100...120 V +10 % / -15 % possible, but in the case of undervoltage torque is reduced by about 20 %
- 6) Under nominal conditions; under extreme conditions (e.g. +60 °C, AC 230 V –15 %) approx. –25 %
- 7) Refer to «Replacement of SQN30... / SQN31...»
- 8) **Actuator types in normal printing and other types are available on request**
- 9) When facing the drive shaft and when control voltage is present at end switch I
- 10) Auxiliary switches (in addition to the 2 end switches)
- 11) Integrated relays

Ordering

When ordering, please give type reference of actuator and accessories according to «Type summary».

Following item must be ordered **separately** and is also supplied as a separate item:

- Adapter AGA70.3 for replacing SQN3...

Accessories

Adapter

AGA70.3

Not suited for use with SQN74... / SQN75...!

For mounting the SQN70... / SQN71... in place of the SQN3...;
fitted to the SQN70... / SQN71... with a self-tapping screw.

Screw and washer are included in the supply.



Technical data

General actuator data

Actuator

Mains voltage	AC 230 V –15 % +10 % AC 110 V –15 % +10 %
Mains frequency	50...60 Hz ±6 %
Safety class	
- SQN70... / SQN71...	II to VDE 0631
- SQN74... / SQN75...	I to VDE 0631
Drive motor	synchronous motor
Power consumption	6 VA
On time	60 %, max. 3 min. continuous operation
Angular adjustment	max. 160°, scale range 0...130°
Mounting position	optional
Degree of protection	
- All types	IP 40 to DIN 40050, provided adequate cable entries and fixing screws are used
- SQN74... / SQN75...	IP 20 to DIN 40050, provided lateral knockout hole for cable is used
Cable entry	
- SQN70... / SQN71...	insertable cable gland holder with thread for 2 x Pg9, no locknut required
- SQN74... / SQN75...	openings for locknut for fixing cable glands
	Type of locknut
	1 x Pg9 M Pg9 DIN 46320 MS
	1 x Pg11 M Pg9 DIN 46320 MS
	additional lateral knockout hole for lose introduction of 2 cables with a max. dia. of 6 mm, cable strain relief to be provided by the user (also refer to «Degree of protection»).
	Pg glands and locknuts are not part of the delivery.
Cable connections	screw terminals for min. 0.5 mm ² and max. 2.5 mm ² cross-sectional area
Ferrules	matching the dia. of the stranded wire
Direction of rotation	refer to «Type summary»
Nominal and holding torque	refer to «Type summary»
Run times	
- SQN70... / SQN71...	4...30 s for 90°
- SQN74... / SQN75...	4...60 s for 90°
Coupling	disengagement of drive shaft / geartrain with a pin
Backlash between drive motor and drive shaft	
- As supplied	≤ 1.2° ±0.3°
- After 250,000 cycles	≤ 1.5° ±0.3°
Weight (average)	approx. 500 g

Technical data (cont' d)

End and auxiliary switches	Number of end switches	2
	Number of auxiliary switches	
	– SQN70... / SQN71...	1...2
	– SQN74... / SQN75...	2...4
Actuation	via camshaft, color-coded cams (refer to «Connection diagrams» switches with fine adjustment – SQN70... / SQN71... : II and III – SQN74... / SQN75... : III and IV	
Breaking voltage	AC 24...250 V	
Perm. loading on terminals at $\cos \varphi = 0.9$:		
• Connection diagram ①		
– Terminals 1, 2, 3, 4		< 0.5 A
– Terminals 5, 6, 7		1 A (7 A) ¹⁾
• Connection diagram ①		
– Terminals 1, 2, 6, 7		< 0.5 A
– Terminals 3, 4		1 A (7 A) ¹⁾
• Connection diagram ②		
– Terminals 1, 2, 3		< 0.5 A
– Terminal 4		2 A (14 A) ¹⁾
– Terminal 5		2 A (14 A) ¹⁾
– Terminal 6		1 A (7 A) ¹⁾
– Terminal 7		1 A (7 A) ¹⁾
– Terminal 8		< 0.5 A
• Connection diagram ③		
– Terminals 1, 2, 3, 8, 11		< 0.5 A
– Terminals 4, 5, 7, 10		1 A (7 A) ¹⁾
• Connection diagram ④		
– Terminals 1, 3		< 0.5 A
– Terminal 4		3 A (14 A) ¹⁾
– Terminal 5		3 A (14 A) ¹⁾
– Terminal 6		1 A (7 A) ¹⁾
– Terminal 7		1 A (7 A) ¹⁾
– Terminal 8		< 0.5 A
• Connection diagram ⑤		
– Terminals 1, 2, 3		< 0.5 A
– Terminal 4		2 A (14 A) ¹⁾
– Terminal 5		2 A (14 A) ¹⁾
– Terminal 6		1 A (7 A) ¹⁾
– Terminal 7		1 A (7 A) ¹⁾
– Terminal 8		< 0.5 A
• Connection diagram ⑥		
– Terminals 1, 2, 3, 4, 5		< 0.5 A
– Terminal 6		1 A (7 A) ¹⁾
– Terminal 7		1 A (7 A) ¹⁾
– Terminal 8		1 A (7 A) ¹⁾
• Connection diagram ⑨		
– Terminals 1, 2, 3, 4, 5		< 0.5 A
– Terminal 6		1 A (7 A) ¹⁾
– Terminal 7		1 A (7 A) ¹⁾
– Terminal 8		< 0.5 A
• Connection diagram (F)		
– Terminals 2...7		< 0.5 A
– Terminals 1, 8, 9		1 A (7 A) ¹⁾

• Connection diagram ④	
– Terminals 1, 2	< 0.5 A
– Terminals 3, 4, 5, 6,7 ,8	1 A (7 A) ¹⁾
¹⁾ Amperages in parentheses are permitted as short-time peak loads for max. 0.5 seconds	
Adjustment of cams	
- Without fine adjustment	1°
- With fine adjustment	infinitely

Norms and standards

Environmental conditions

Transport	DIN EN 60 721-3-2
Climatic conditions	class 2K2
Mechanical conditions	class 2M2
Temperature range	-50...+60 °C
Humidity	< 95 % r.h.
Operation	DIN EN 60 721-3-3
Climatic conditions	class 3K5
Mechanical conditions	class 3M2
Temperature range	-20...+60 °C
Humidity	< 95 % r.h.



Condensation, formation of ice and ingress of water are not permitted!

Function

The synchronous motor drives the drive shaft which carries the camshaft.

The camshaft actuates the end and auxiliary switches.

Using the associated cam, the switching position of each end and auxiliary switch can be adjusted within the working range.

Some of the actuator versions are equipped with electronic modules that perform auxiliary functions in connection with the end and auxiliary switches or with external devices, such as controllers (refer to «Connection diagrams»).

The functions and technical data of both lines of actuators SQN70... / SQN71... and SQN74... / SQN75... are nearly identical.

Replacement of SQN30... / SQN31...

Using an adapter (refer to «Accessories»), actuators type SQN30... and SQN31... can be replaced by the SQN70... / SQN71... .

There are no mechanical modifications required.

The different terminal assignments of the 2 types of actuators must be observed, however.

The «Type summary» contains the **SQN3...** that can be replaced by SQN7...actuators.

The **SQN30...** and **SQN31...** listed in «Type summary»

- refer to the SQN7... AC 230 V versions.
The respective SQN3... AC 110 V versions use the same type reference as the AC 230 V versions, with one exception: Type suffix ..A27.. is replaced by ..A17.. .
- are versions **with no** facility for fitting a potentiometer (refer to Data Sheet 7808)

Nr. ④ → LOA24.171.../LOA24.173.../LOA24.174.../LOA24.571.../LOA25.../LOA26...
 LOA28.../LOA36.../LMO24.../LMO44...
 2-stage operation
 Prepurge at low-fire position <KL> (see <S5>)

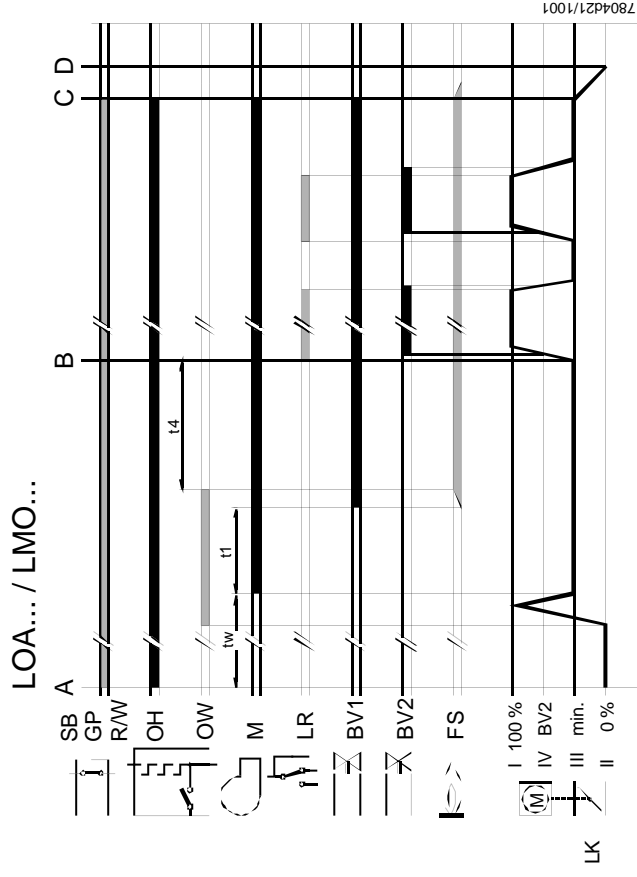
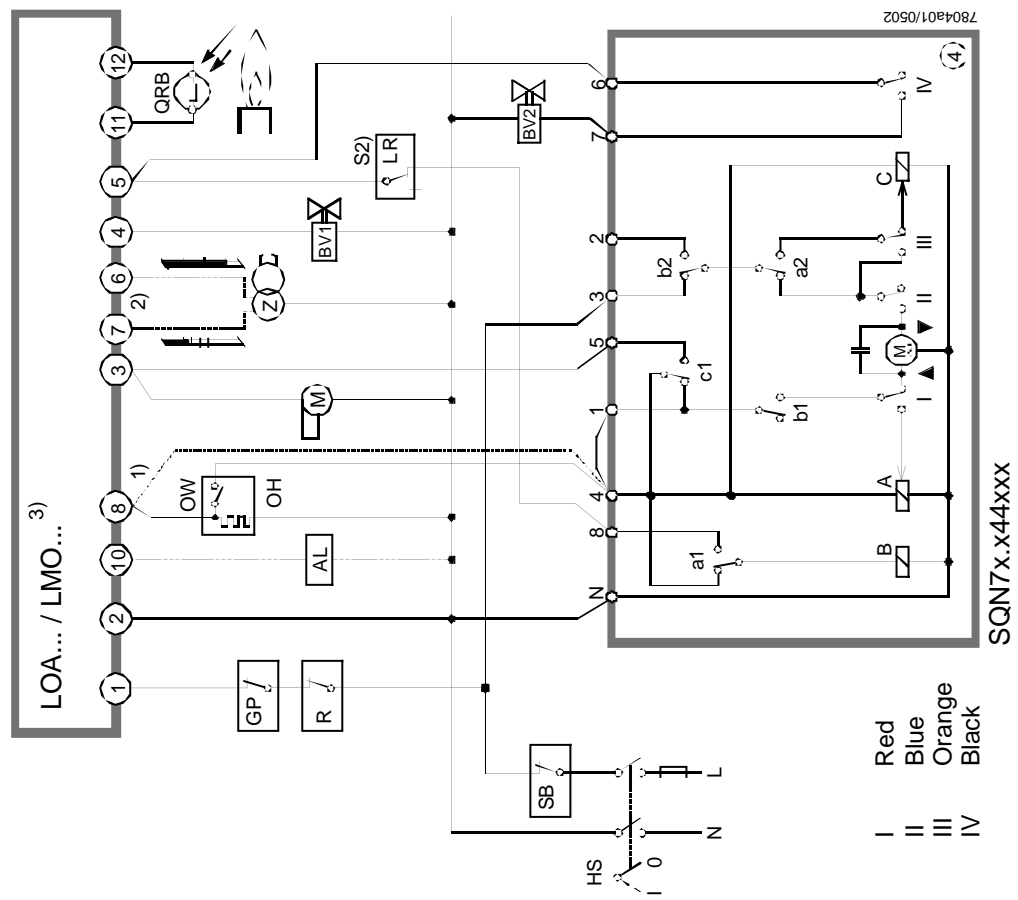

- 1) Without oil preheater
- 2) Refer to Data Sheet 7118
- 3) LOA... / LMO... with oil preheater:
 If contact <OW> opens during operation, there will be a complete new start

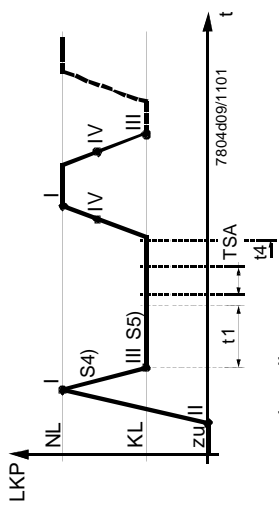

For notes on <S1...S5> refer to <Notes on connection diagrams>

2-stage operation
Prepurge at low-fire position <KL> (see <S5>)

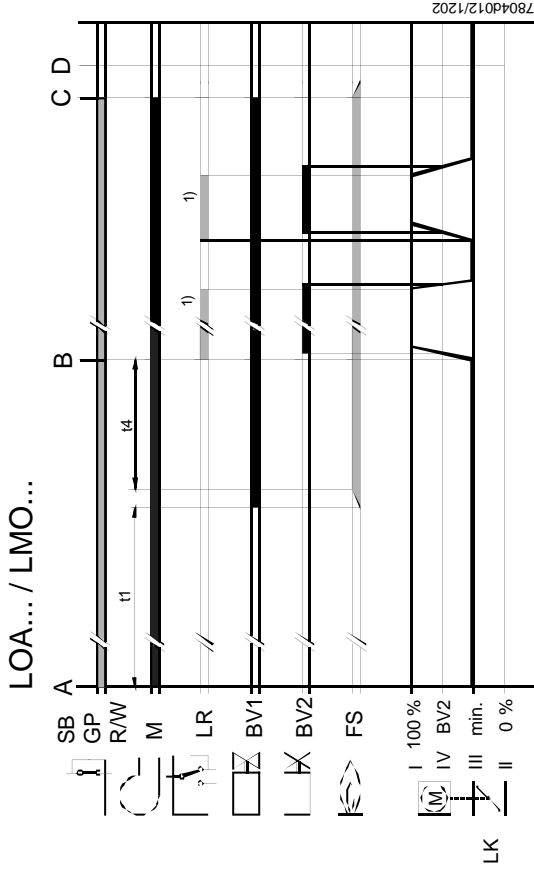
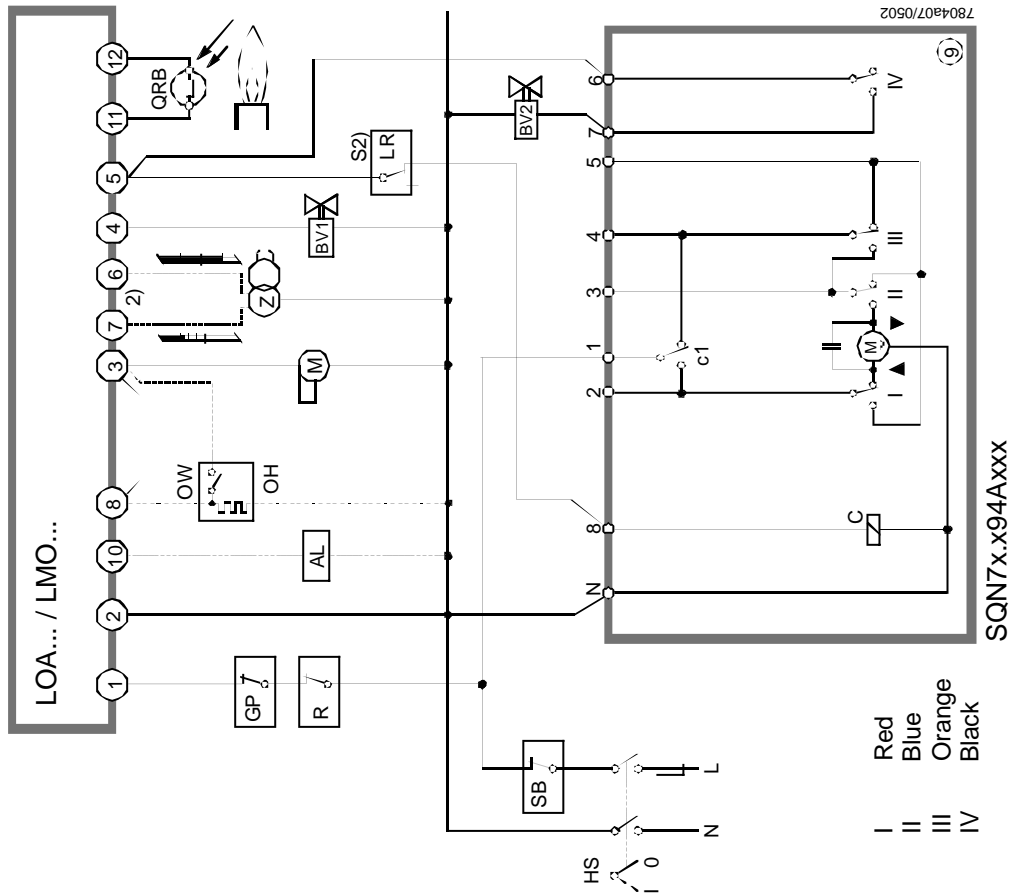

Program sequence without oil preheater
 1) Voltage at terminal no. 8 of the SQN7 ...
 2) Refer to Data Sheet 7118

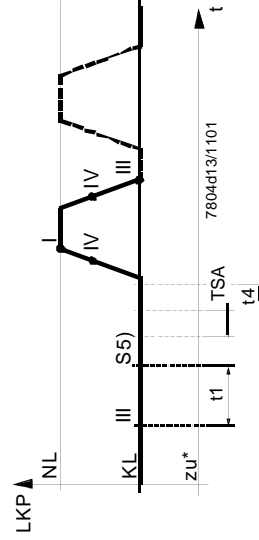

* When burner is <OFF>, the air damper maintains position <KL>.
 No <Damper CLOSED> position, refer to notes on connection diagrams → <S3>.
Connection diagram no. ④ → LOA... / LMO... used the same function with air damper closed when burner is <OFF>.

For notes on <S1...S5> refer to <Notes on connection diagrams>

Nr. ② → LGB22... / LGB32... and LMG22...

2-stage or modulating operation
Prepurge at nominal load position <NL>

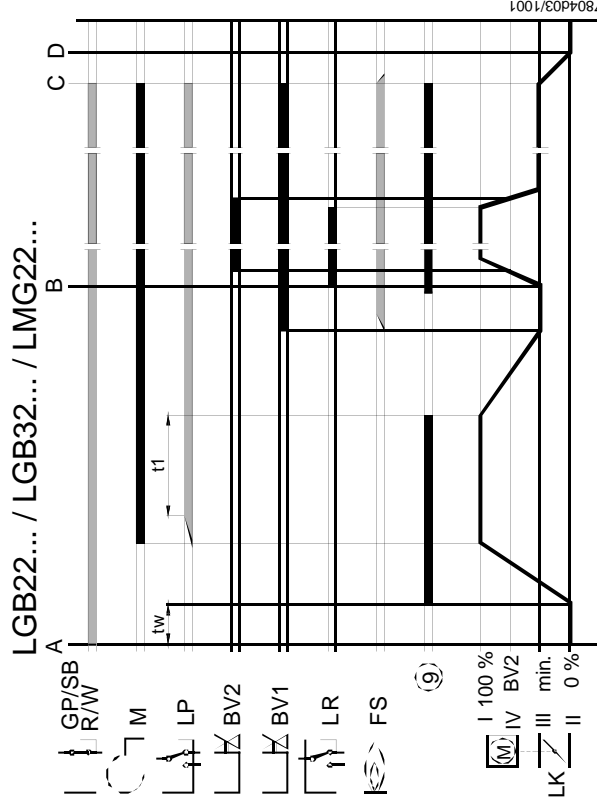
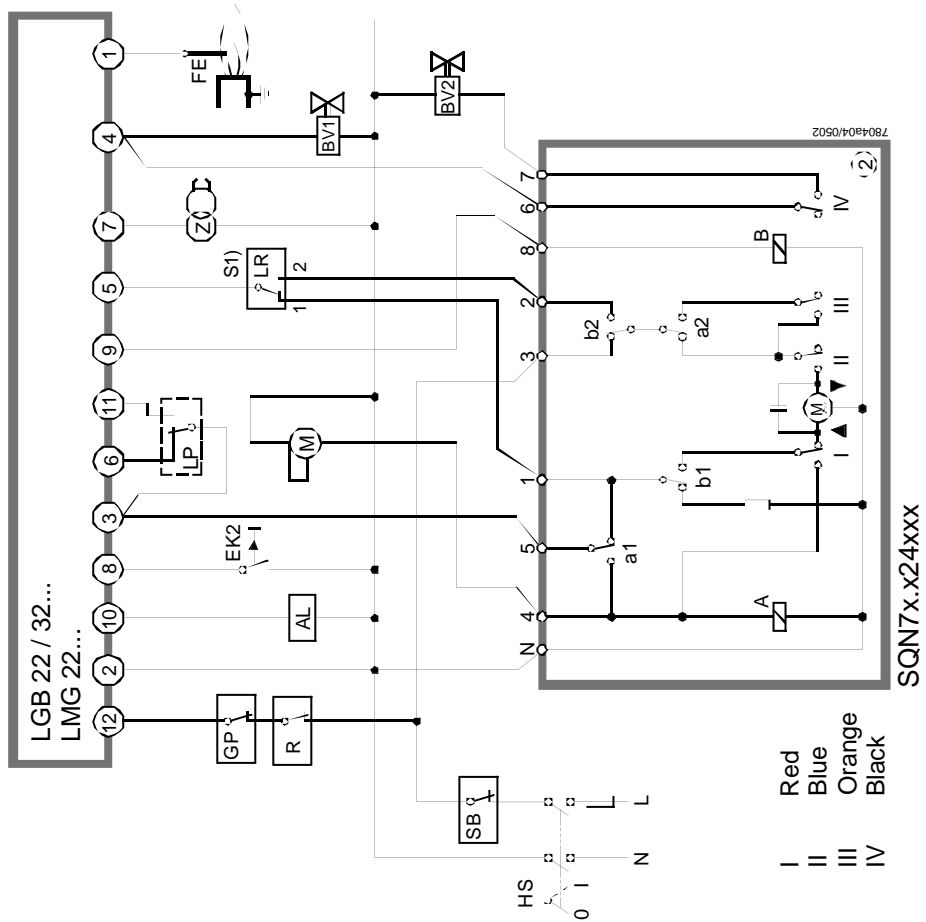

Program sequence diagrams show 2-stage operation.
For modulating operation, refer to <S1>.

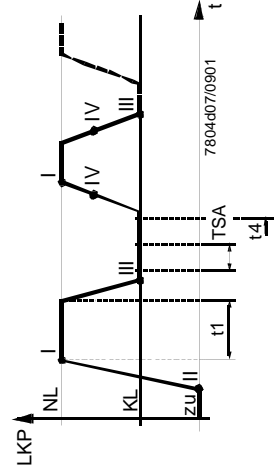

For notes on <S1...S5> refer to <Notes on connection diagrams>

2-stage operation
Prepurge at nominal load position <NL>

LGB22... / LGB32... / LMG22...

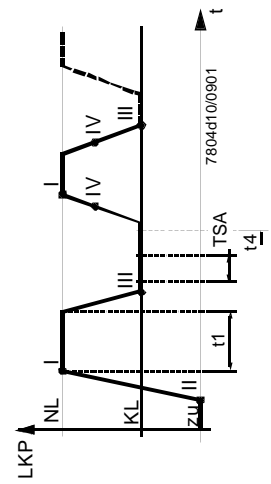
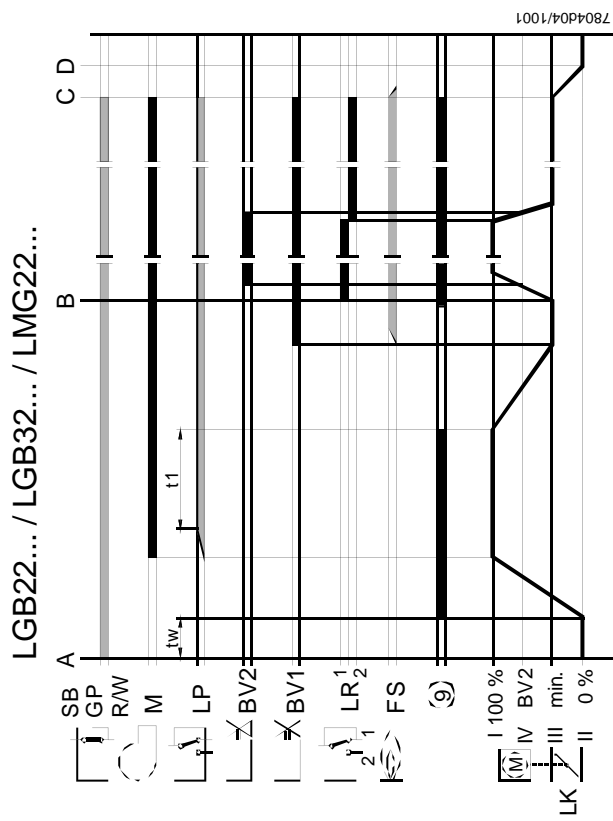
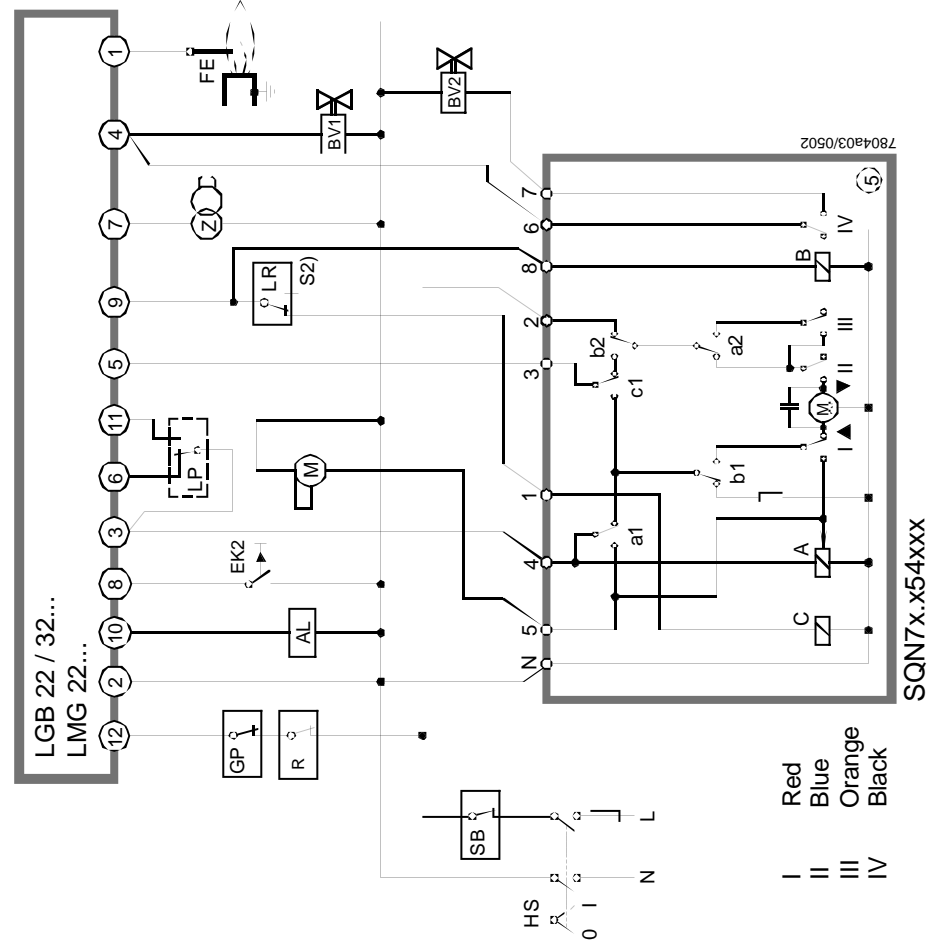

For notes on <S1...S5>, refer to <Notes on connection diagrams>

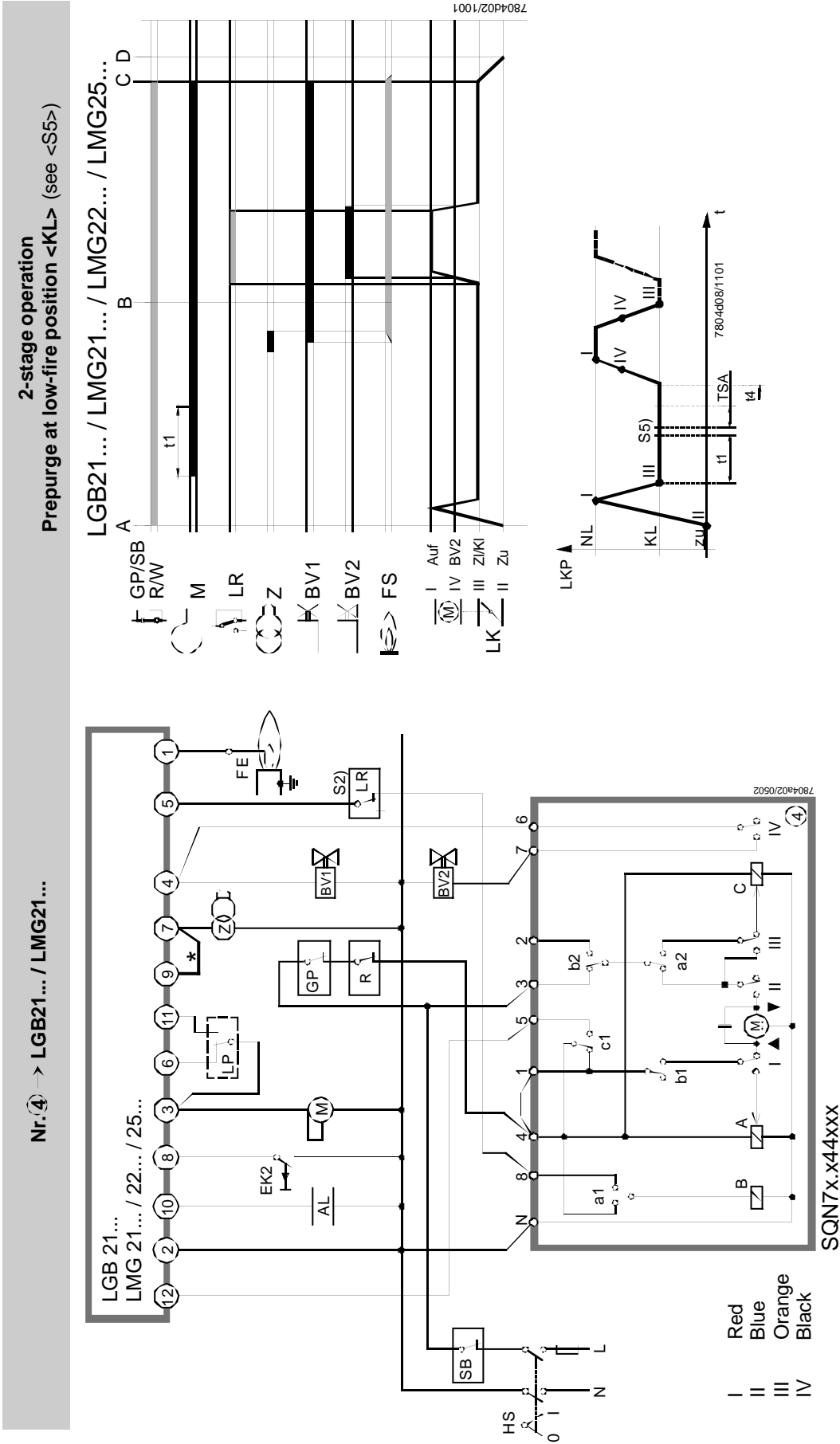

For notes on <S1...S5>, refer to <Notes on connection diagrams>

2-stage or modulating operation
 Prepurge at nominal load position <NL>

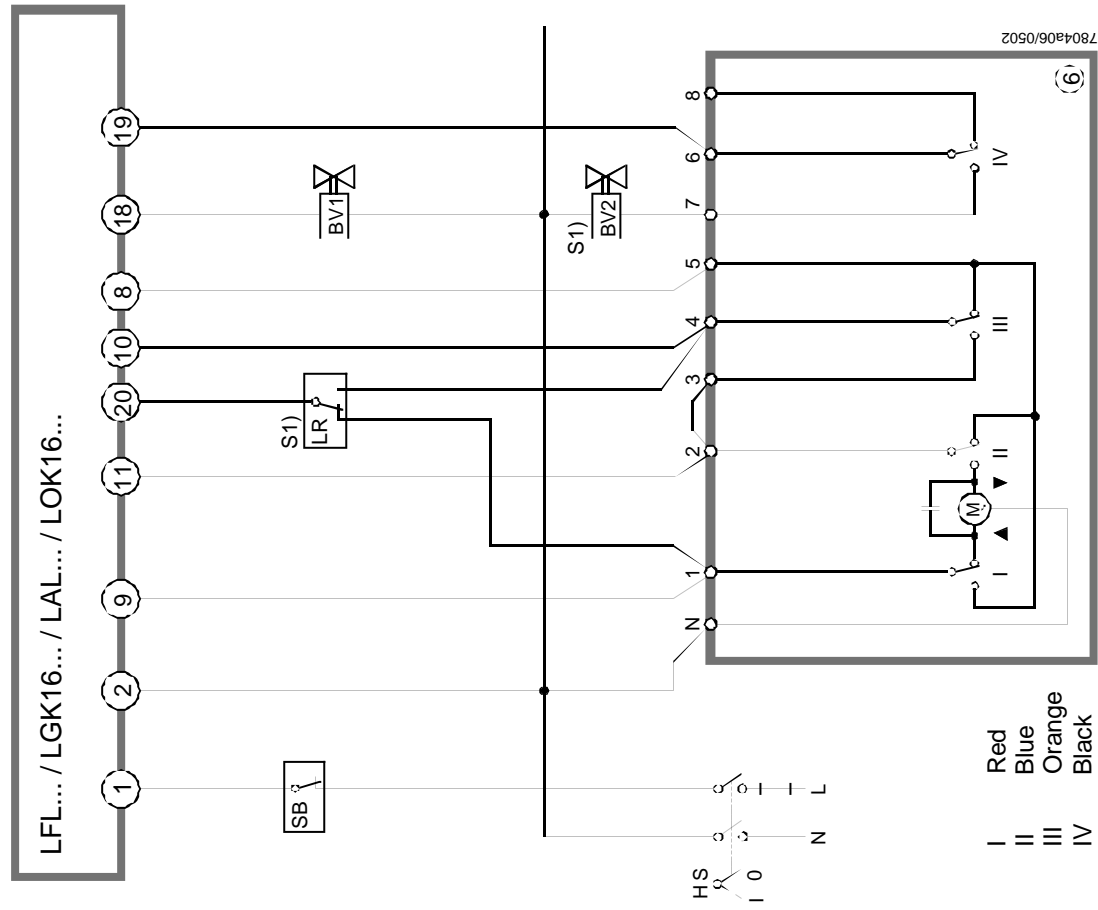

- I Red
- II Blue
- III Orange
- IV Black

SQN7x.x64xxx

For notes on <S1...S5>, refer to <Notes on connection diagrams>

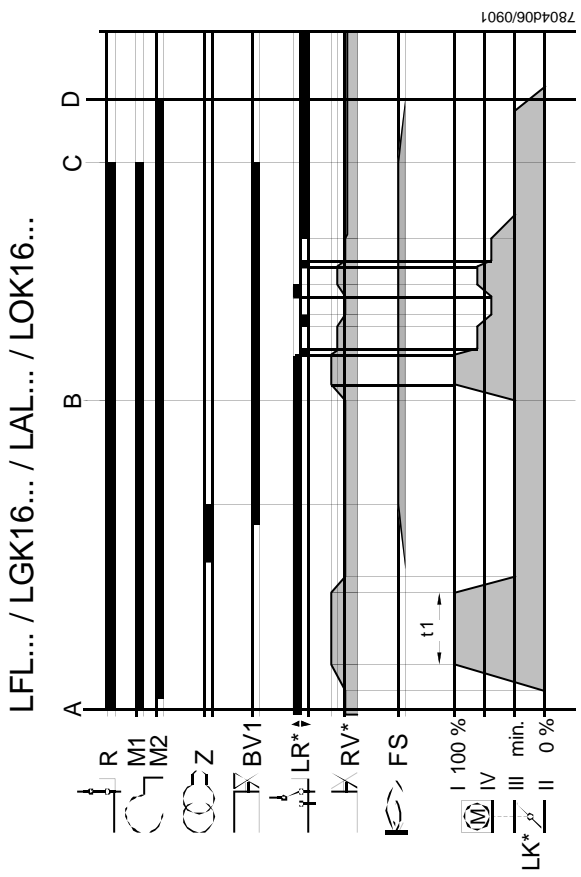

* Modulating

Program sequence diagrams show modulating operation.
 For 2-stage operation, refer to <S1>

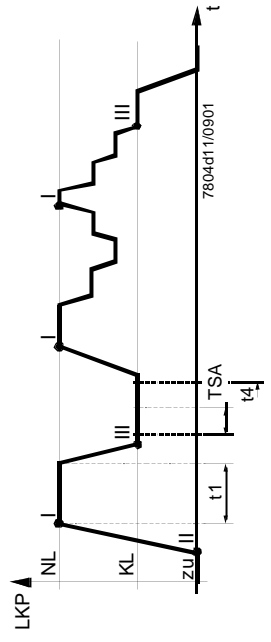

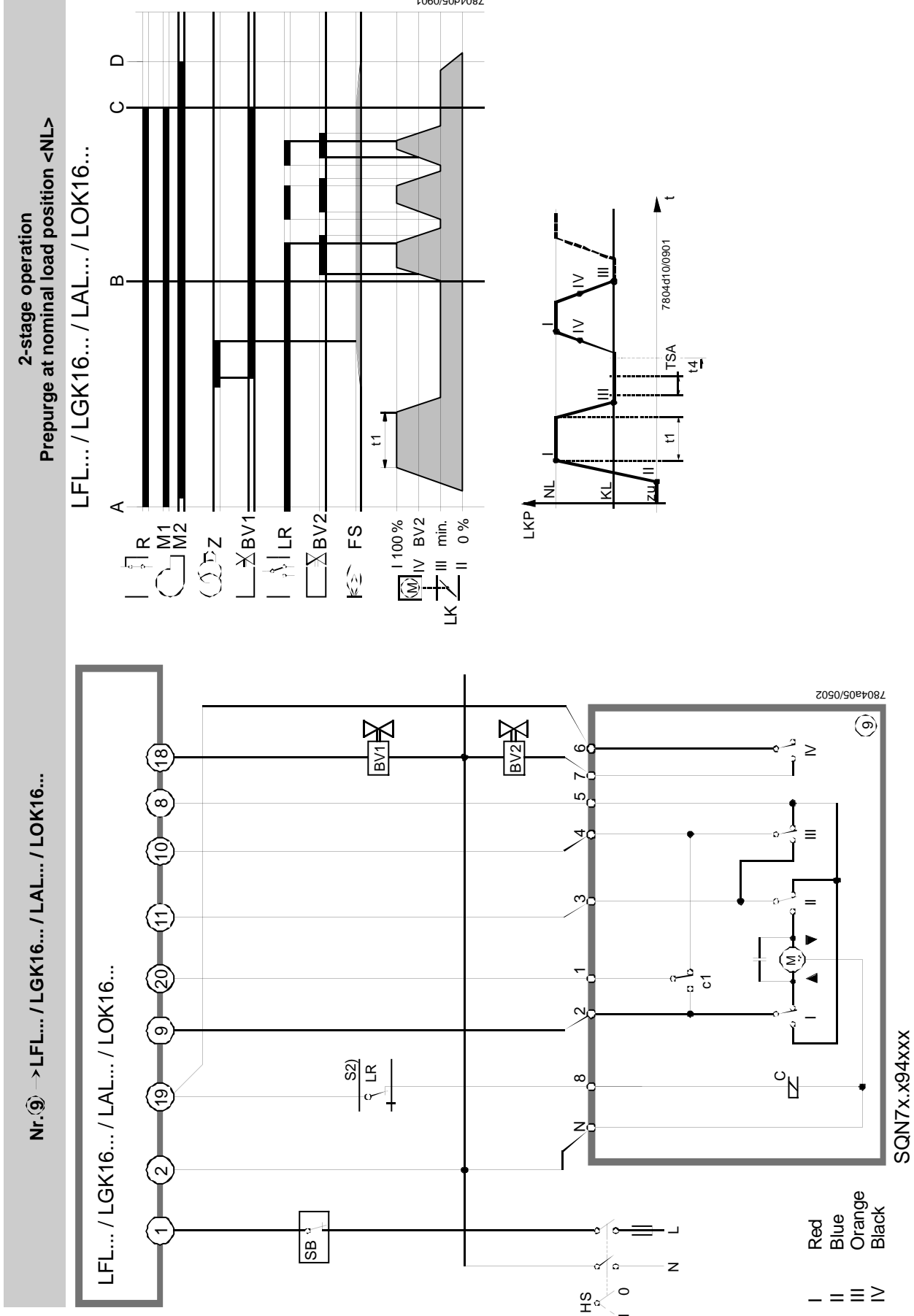

For notes on <S1...S5>, refer to <Notes on connection diagrams>

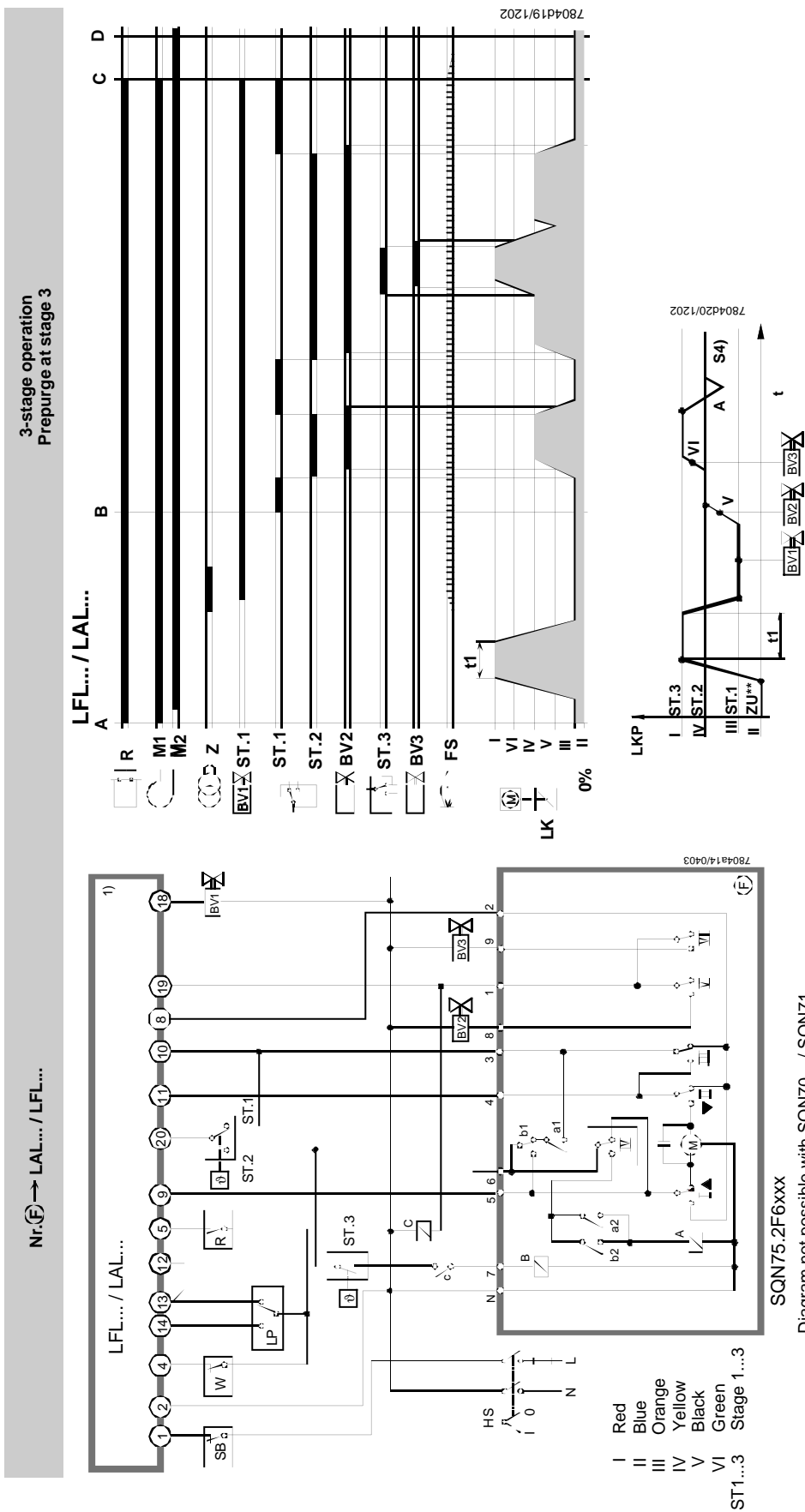

For notes on <S1...S5>, refer to <Notes on connection diagrams>

2-stage operation
Prepurge at nominal load position <NL>

Nr. ① → TMG740 / TMO720

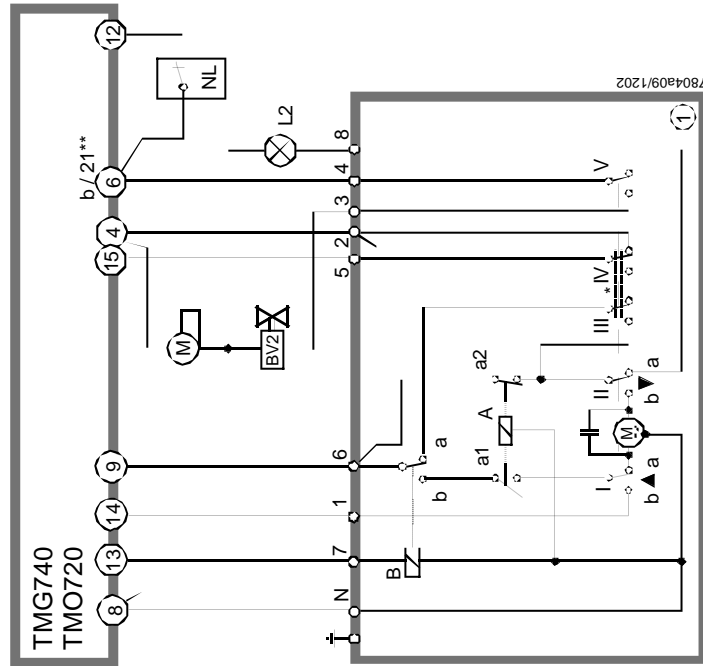

- I Red
- II Blue
- III Orange
- IV Orange
- V Black

SQN74.x15xxx
SQN75.x15xxx

** TMO720 terminal no. 6
TMG740 terminal no. 21

• **TMG... / TMO... are devices of other manufacture; they are neither made nor supplied by us. The combination with our actuator proposed here must be checked with the supplier of the TMG... / TMO... while taking into consideration safety aspects and the current version of the burner control. The user assumes full responsibility for this application.**

• Wiring diagram no. ① corresponds to wiring diagram no. ③ of the SQN3...
Application only possible with SQN74... / SQN75...

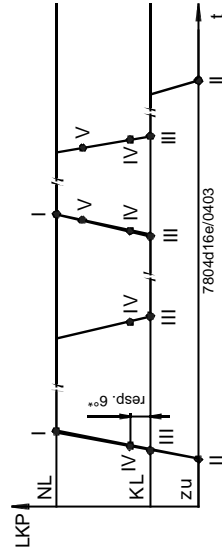

* Cams III and IV are rigidly connected

For notes on <S1...S5>, refer to <Notes on connection diagrams>

Nr. ① ② Universal use

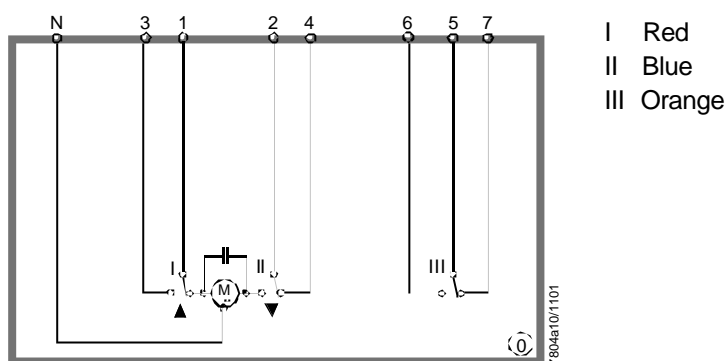

SQN7x.x03xxx



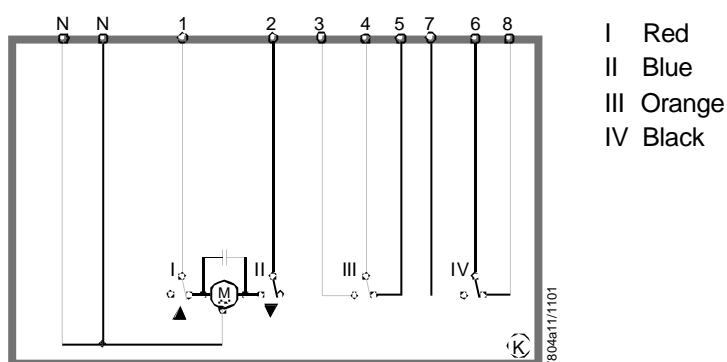

Nr. ③ ④ Universal use



SQN7x.xK4xxx

For notes on «S1...S5», refer to «Notes on connection diagrams»

Legend

No. ②	Number corresponds to the designation number or letter of the internal circuit of the SQN7... (second character after the dot in the type code)
AL	Remote indication of fault (alarm)
BV1	Fuel valve stage 1
BV2	Fuel valve stage 2
BV3	Fuel valve stage 3
EK2	External remote reset button
FE	Ionization probe
FS	Flame signal amplifier
GL	Air / gas ratio controller
GP	Gas pressure switch
HS	Main switch
KL	Low-fire
L	Live
LK	Air damper
LKP	Air damper position
LP	Air pressure switch
LR	Load controller (also refer to «S1»)
M	Burner or fan motor
	Actuator's drive motor
M1	Without postpurge
M2	With postpurge
N	Neutral conductor
NL	Nominal load
OH	Oil preheater
OW	Oil preheater's readiness contact
QRB...	Photoresistive flame detector
R	Temperature or pressure controller
	Relay
RV	Controller damper
SA	Actuator
	Fuse
SB	Safety limiter
ST...	Stage
t... / T...	Program time (refer to the Data Sheet of the relevant burner control)
TSA	Safety time
	Resistance
Z	Ignition transformer
ZU	Damper fully closed
▲	Direction of rotation OPEN
▼	Direction of rotation CLOSE

Program sequence – diagrams

A	Burner ON
A – B	Startup of burner
B – C	Burner operation / load control operation, modulating or 2-stage
C	Burner OFF
C – D	Overrun time
D	End of program, burner control ready for new start

Notes on connection diagrams

S1) Controller for:

- **2-stage operation**

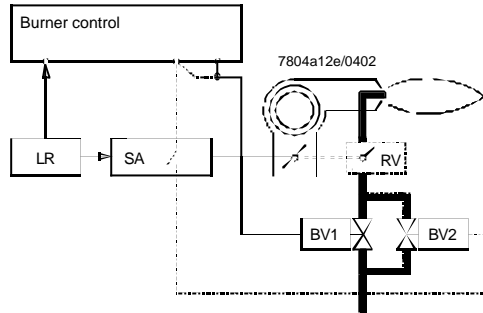

Thermostat or similar, with changeover contact (2-wire control).

In place of «BV2», it is possible to use a control damper that is rigidly connected to the air damper (shown in broken lines).

- **Modulating operation**

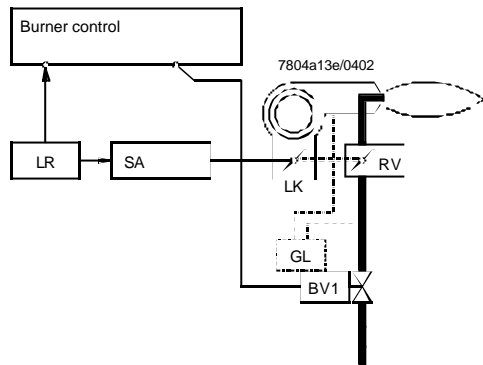

3-position controller for OPEN / CLOSE positioning pulses with neutral position in between (2-wire control).

«BV2» is not used. Air / gas ratio control is used instead.

This can be accomplished in the form of

- a control damper «RV» that is rigidly connected to the air damper, or
- an air / gas ratio controller «GL» type SKP70... (refer to Data Sheet 7651) that – if combined with safety shutoff – is used in place of «BV1» (shown in broken lines)

LR load controller for temperature or pressure control
Type **RWF40...**

- Digital PID universal controller for
- temperature or pressure control
 - 2-stage or modulating operation, and with special functions for heat generation plant (refer to Data Sheet 7865)

S2) Thermostat or similar with N.O. contact (single-wire control).

S3) In heating systems **where the air damper does not fully close in the case of burner OFF**, thermal uplift occurs in the flueways (boiler, stack), causing the boiler to cool down rather quickly, thus giving rise to increased heat losses.

S4) If, during the program sequence, a damper position switch is approached from both sides, it is not actuated in the same damper position, due to the switching differential. To ensure that actuation takes place in the same position, the program sequence makes certain the required damper position will be passed for a short period of time.

S5) The prepurge rate of the heat generation system (boiler, stack, etc.) prior to establishment of the flame must be in compliance with country-specific regulations. As a general rule, the prepurge rate with oil burners should be 3 times the volume of the heat generation system, and with gas burners, 5 times that volume. But these are only guide values. The effective prepurge volume required depends primarily on the type of construction of the heat generation system and is entirely the responsibility of the manufacturer of that system. If prepurging is selected for the low-fire position, the **prepurge time** is to be appropriately extended (against prepurging for the nominal load) to attain the required air volume.

- **For supplementary connections** on the burner controls, refer to the relevant Data Sheets
- For auxiliary switches with fine adjustment, refer to «Technical data»
- In the connection diagrams, **the positions of the end and auxiliary switches** I...VI in the actuator for the working range are shown between 0° and the adjusted angular position of the cams, that is, in the start position

Dimensions

Dimensions in mm

SQN70... / SQN71...

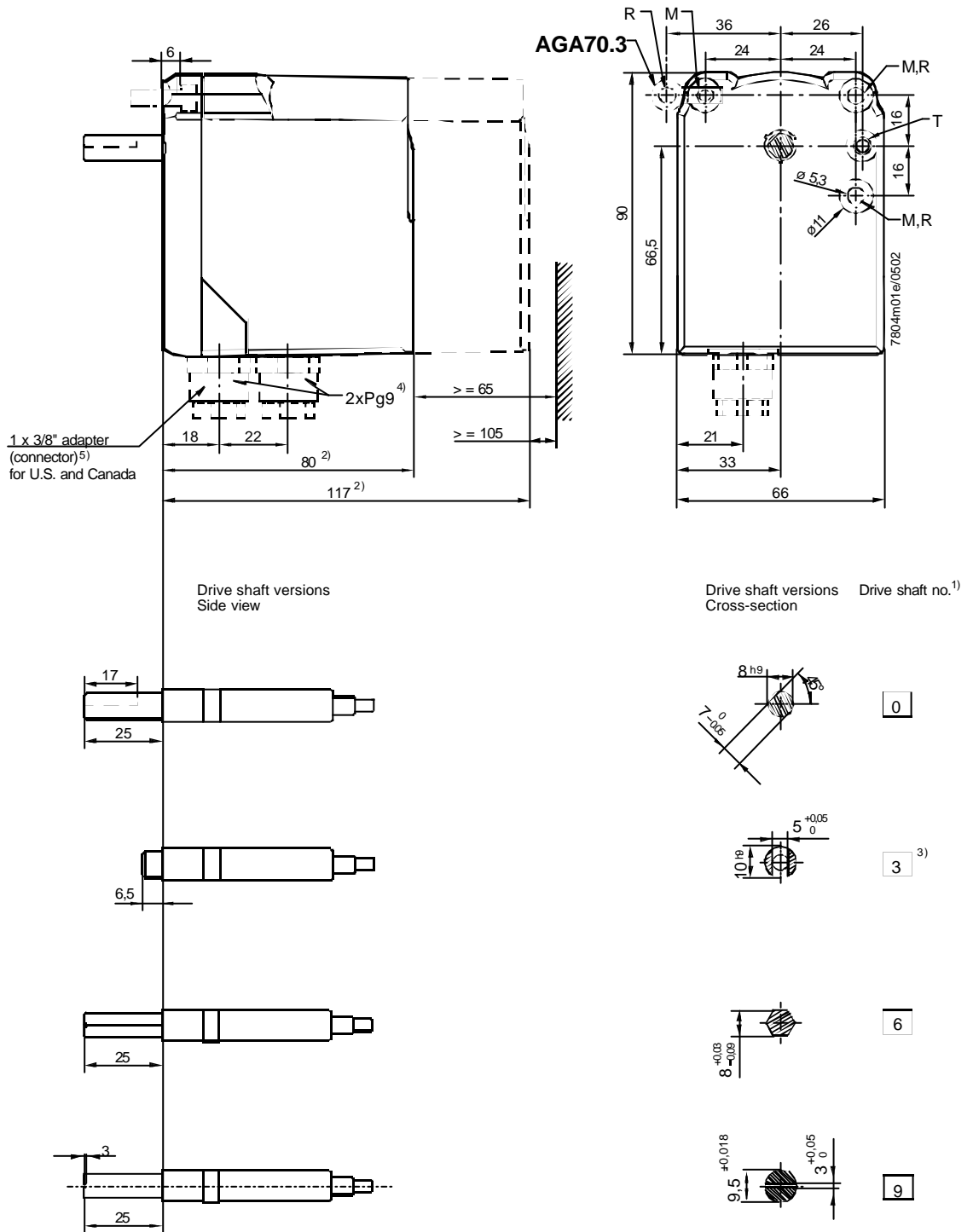

- 1) Drive shafts are shown in their fully closed position (voltage present at end switch II)
Drive shaft no. is identical with the 6th character after the dot in the type reference
Example: SQN70.664A23 = drive shaft no. **3**
 - 2) Length of housing depends on the type of actuator (refer to «Type summary»)
 - 3) Center slot: 6.3 mm deep
Hole dia. 5.1 mm: 16.5 mm deep (including depth of center slot)
 - 4) Not part of the delivery
 - 5) Supplied with types SQN7x.xxxRxx
- R Fixing positions matched to SQN3...
(for 1-to-1 replacement by SQN70... / SQN71..., use AGA70.3)
- M Through-hole 5.3 mm dia.
T Knockout hole 5.3 mm dia.

Dimensions in mm

SQN74... / SQN75...

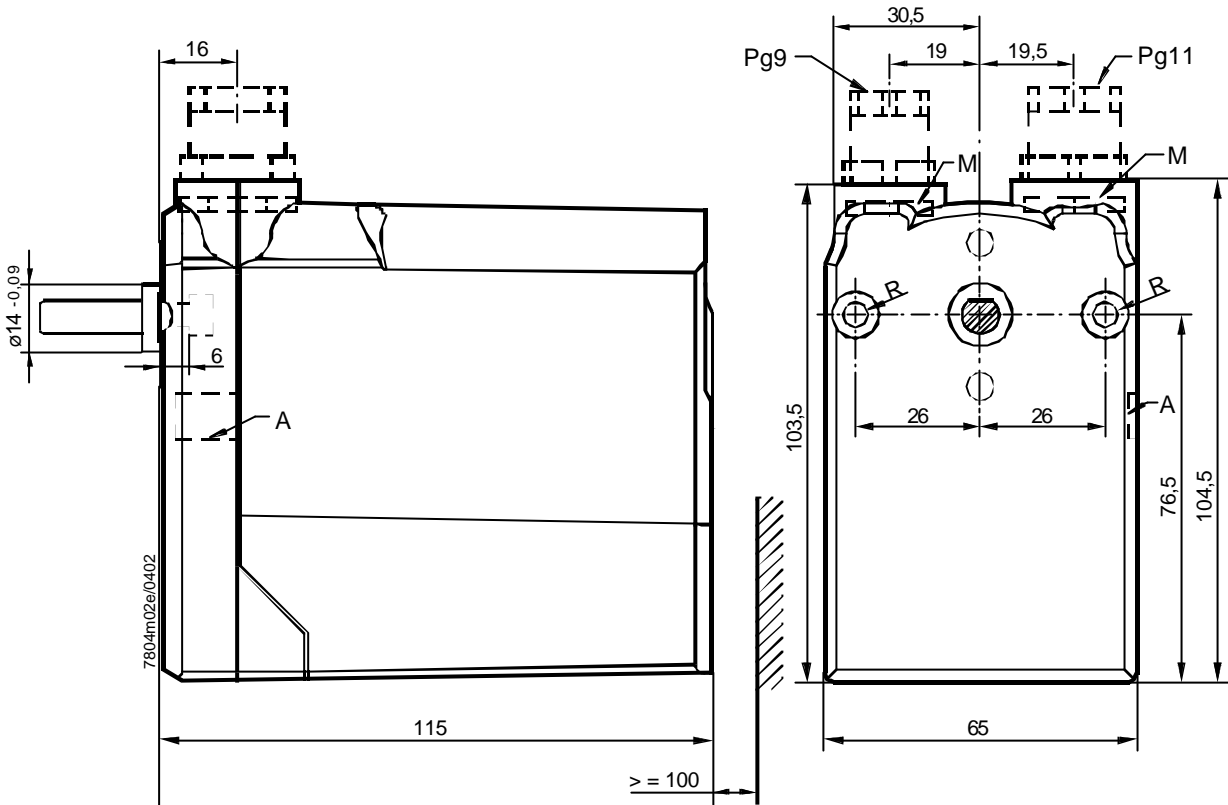

Drive shaft version
Side view

Drive shaft version
Cross-section

Drive shaft no. ¹⁾

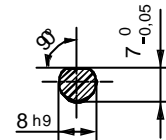
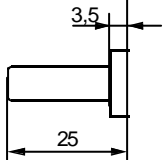

1

- 1) Drive shaft shown in fully closed position (voltage present at end switch II)
- A Knockout hole for lose cable entry
- R Through-hole 5.3 mm dia.
Fixing positions matched to Conectron LKS 160 and Berger STA
- M Pg nuts, not part of the delivery (for type reference, refer to «Technical data»)