

GVN STANDART PRODUCT

Customer

FILTER DRIER SHELLS

Product

H48.45B.76.1

Code

Customer Code

DESIGN DATA

Capacity [Lt.]	1,6 Lt.
Design Pressure [PS]	45 Bar
Pneumatic Test Pressure [PT]	50 Bar
Hydraulic Test Pressure	65 Bar
Design Temperature [TS]	Min.-20C / Max.+130C
Cooler Fluid Type	HFC-CFC-HCFC-R744
Fluid Group	2
Category	CAT I / A
Desing Calculation	EN 14276-1/EN 13445-3
Welded Joint Efficiency	0.85
Material Group (Shell / Head)	1.2
Testing Group	3b
Corrasion Allowance	0,1 mm
Ndt	10%
Packaging Size & Weight	00*00*00 & 00 Kg.
Drawed By	Ö.TÜRKER
Approved By	D.GÜL
Date	10.01.2025
Color	RAL 5009

MATERIAL DATA

No	Connection	Model	Code	Qty
1	Inlet connection	ODS 3" H:60	106.033.B13.H48.060	1
2	Outlet connection	ODS 3" H:60	106.033.B13.INL.T60	1
3	Shell	Ø114,3x3 H:165	204.H48.45B.080.001	1
4	Head	Ø114x4 H:26	101.060.114.001.010	1
5	Bottom Flange	Ø149x12	107.045.H48.114.002	1
6	Top Flange	Ø149x9	107.045.H48.114.001	1
7	Klingerite Gasket	(Ø114,5-Ø106,5)	108.114.106.000.K01	1
8	Bolt	M8X25	109.080.025.088.C01	8
9	Washer	M8	109.080.000.000.R01	8
10	Blind Plug	NPT 1/4"	106.130.F02.KTP.023	1
11	Filter holder		M012.000032	1

GENERAL NOTES

- Max. allowable operating pressure (PS) according to the temperature range;
- 1) Allowable operating temperature : min. -20C° / max. +130C° PS1 = 45 Bar
- 2) Allowable operating temperature : min. -40C° / max. -20C° PS2 = 33 Bar
- Unless otherwise specified dimensions in MM
- Unless otherwise specified do not scale
- Unless otherwise specified tube must be clean&free form burrs inside&outside&uitable for soldering
- Unless otherwise specified do not scale indicated thickness are min. after forming or machining
- Unless otherwise specified dimension tolerances according to EN 13445-4

REVISIONS

No	Details Of Change	Date	By
01	in-out bağlantıları 33b yapıldı.	16.04.2025	Ö.TÜRKER
02			
03			

RELATED DRAWINGS

No	Description	Drawing No
01		
02		



We reserve all rights in this document and in the information contained therein. Reproduction use or disclosure to third parties without express authority is strictly forbidden.

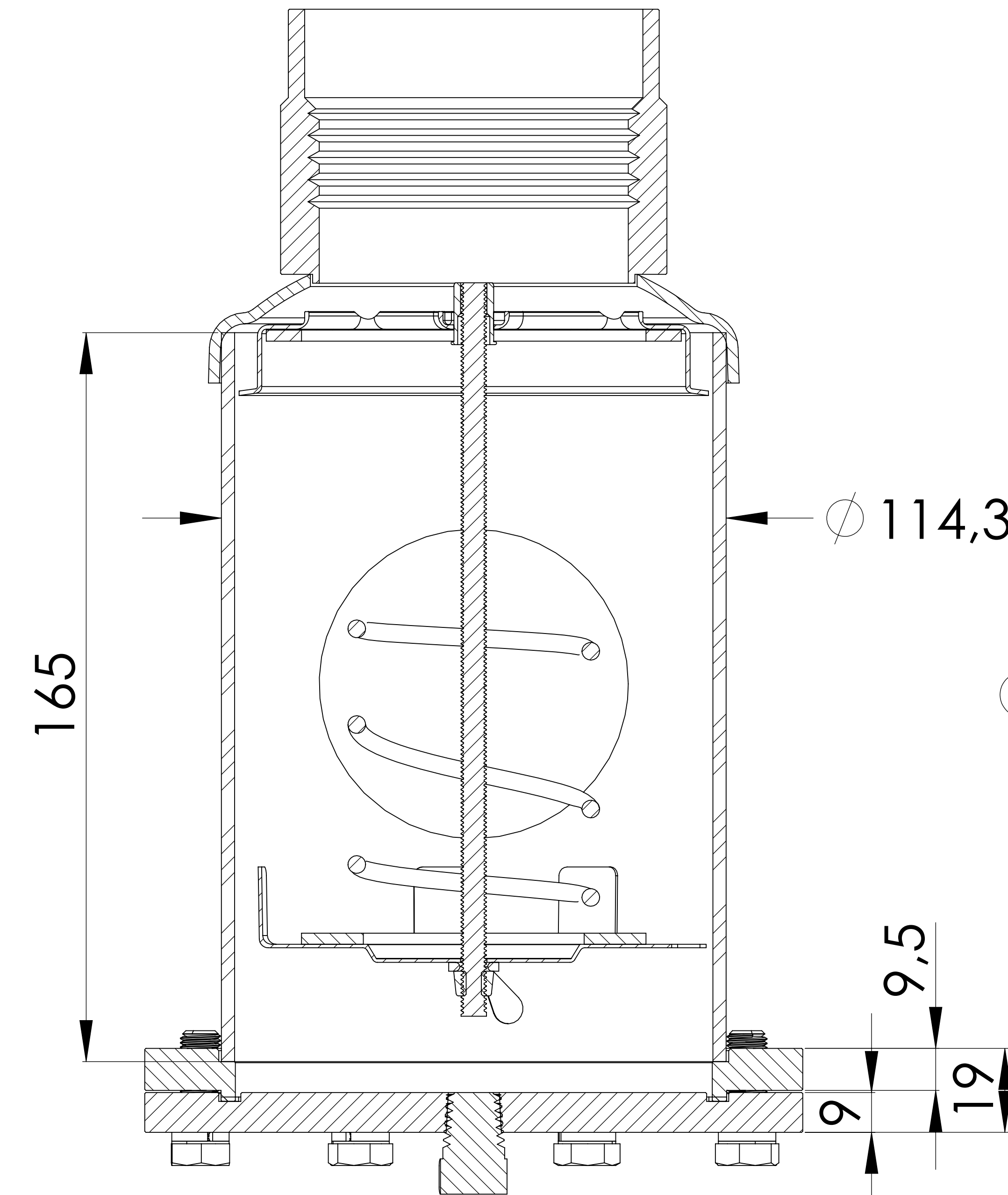
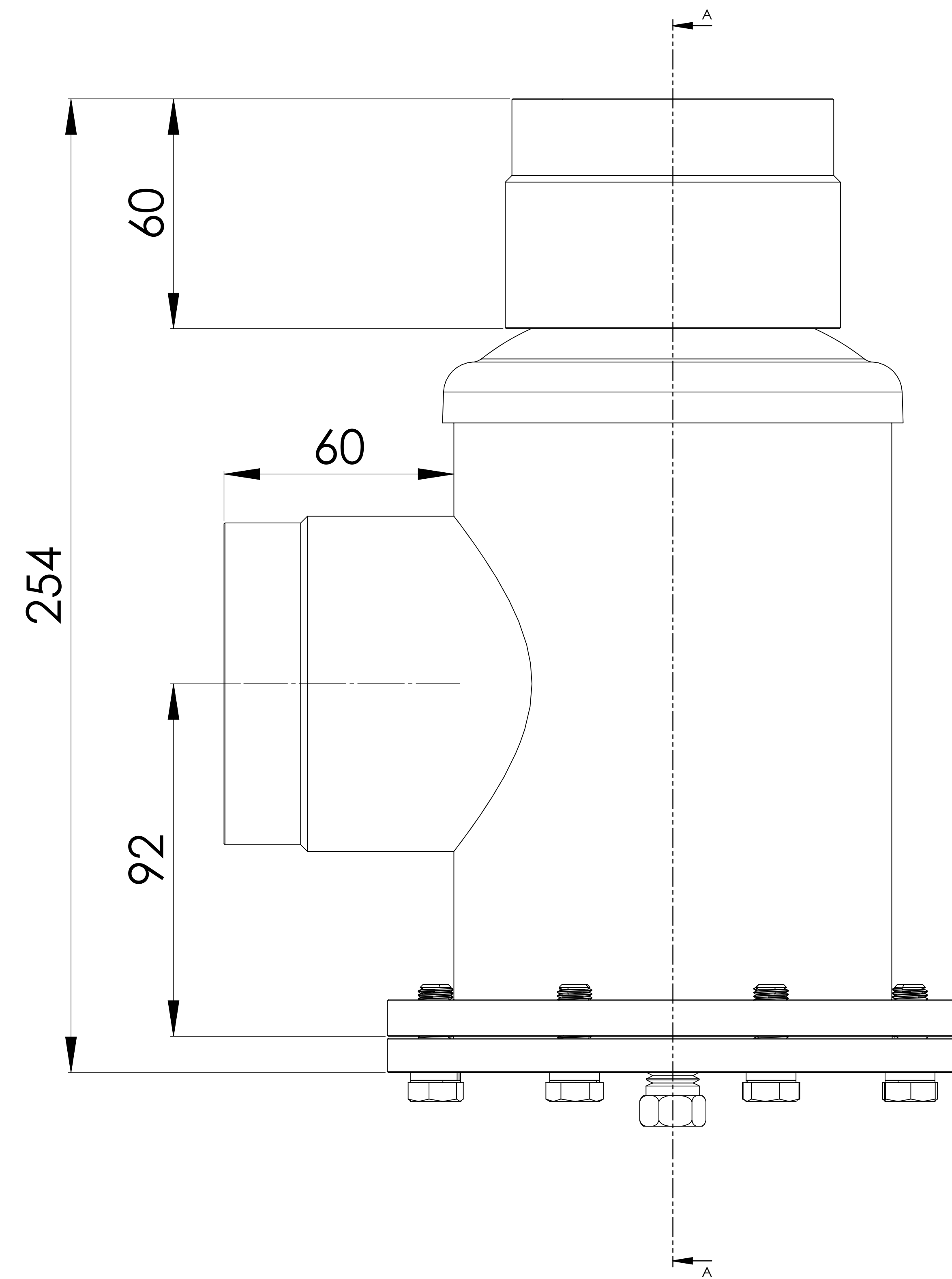

KESİT A-A
ÖLÇEK 1:0.8

