

KESİT A-A
ÖLÇEK 1 : 0.8

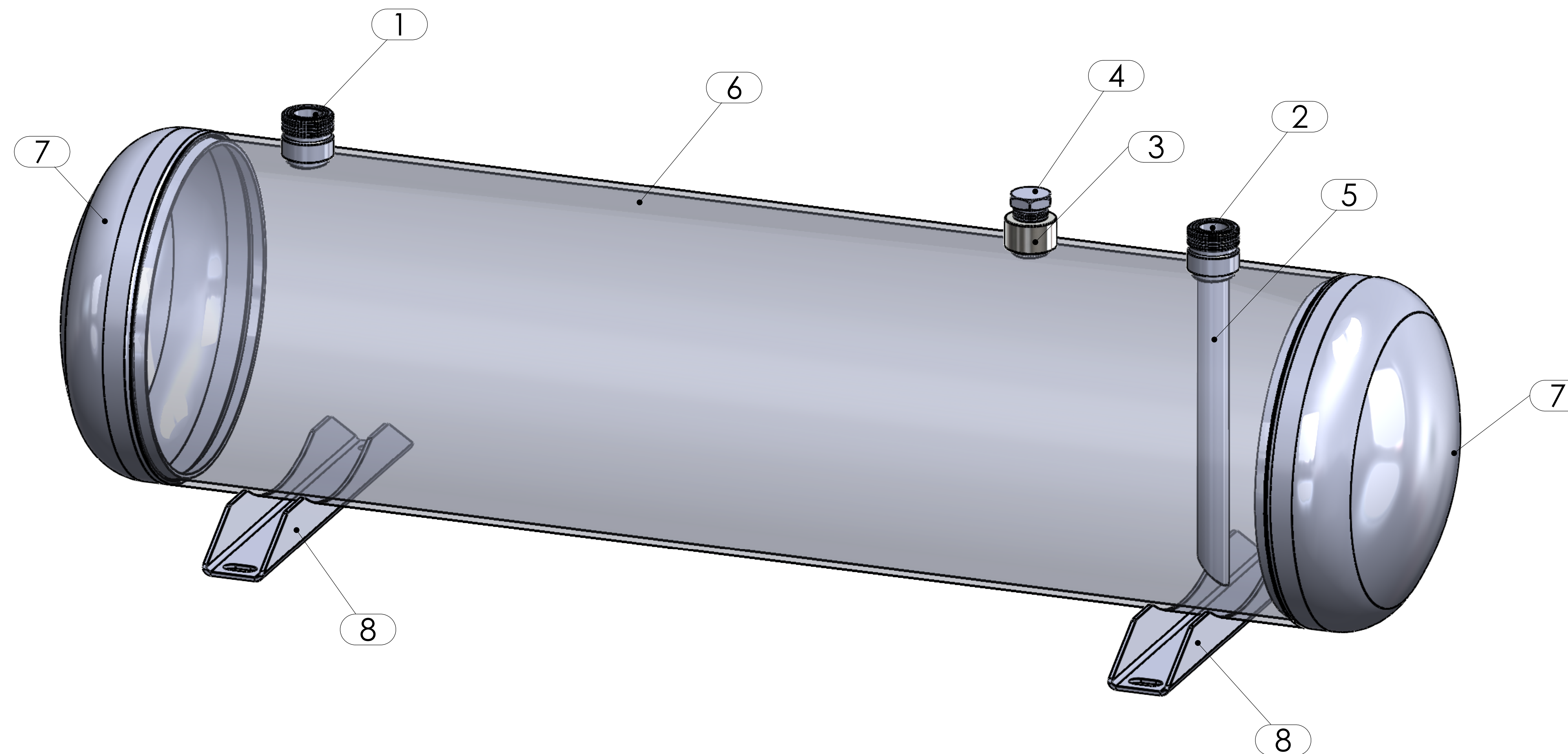

GVN STANDART PRODUCT Customer

HORIZONTAL LIQUID RECEIVERS Product

H7A.33b.30.A3.A3.F4 Code

Customer Code

DESIGN DATA

Capacity [Lt.]	30 Lt.
Design Pressure [PS]	33 Bar
Pneumatic Test Pressure [PT]	36 Bar
Hydraulic Test Pressure	48 Bar
Design Temperature [TS]	Min.-20C / Max.+130C
Cooler Fluid Type	HFC-CFC-HCFC
Fluid Group	2
Category	CAT II / D1
Desing Calculation	EN 14276-1/EN 13445-3
Welded Joint Efficiency	0.85
Material Group (Shell / Head)	1.2
Testing Group	3b
Corrasion Allowance	0,1 mm
Ndt	10%
Packaging Size & Weight	00*00*00 & 00 Kg.
Drawed By	Ö.TÜRKER
Approved By	D.GÜL
Date	05.01.2023
Color	RAL 5009

MATERIAL DATA

No	Connection	Model	Code	Qty
1	Inlet Connection	ROT. 1 1/4" H:27	106.060.A03.001.T27	1
2	Outlet Connection	ROT. 1 1/4" H:27	106.060.A03.001.T27	1
3	Safety Valve Conn.	NPT 1/2" H:18	106.060.F04.NPT.T18	1
4	Blind Plug	NPT 1/2" Plug	106.130.F04.KTP.023	1
5	Pipe	Ø19x1,5 H:210	104.019.015.000.210	1
6	Shell	Ø219,1x4 H:745	204.H07.33B.030.001	1
7	Head Torispheric	Ø219x2,5 H:75	101.033.219.001.000	2
8	Foot	260x40x31,5 t:3	105.002.219.001.001	2

GENERAL NOTES

- Max. allowable operating pressure (PS) according to the temperature range;
- 1) Allowable operating temperature : min. -20C° / max. +130C° PS1 = 33 Bar
- 2) Allowable operating temperature : min. -40C° / max. -20C° PS2 = 24 Bar
- Unless otherwise specified dimensions in MM
- Unless otherwise specified do not scale
- Unless otherwise specified tube must be clean&free from burrs inside&outside&uitable for soldering
- Unless otherwise specified do not scale indicated thickness are min. after forming or machining
- Unless otherwise specified dimension tolerances according to EN 13445-4

REVISIONS

No	Details Of Change	Date	By
01			
02			
03			

RELATED DRAWINGS

No	Description	Drawing No
01		
02		



No	Assembly Codes	Qty
1	M002.000029	1

We reserve all rights in this document and in the information contained therein. Reproduction use or disclosure to third parties without express authority is strictly forbidden.