

KESİT A-A
ÖLÇEK 1 : 0.8

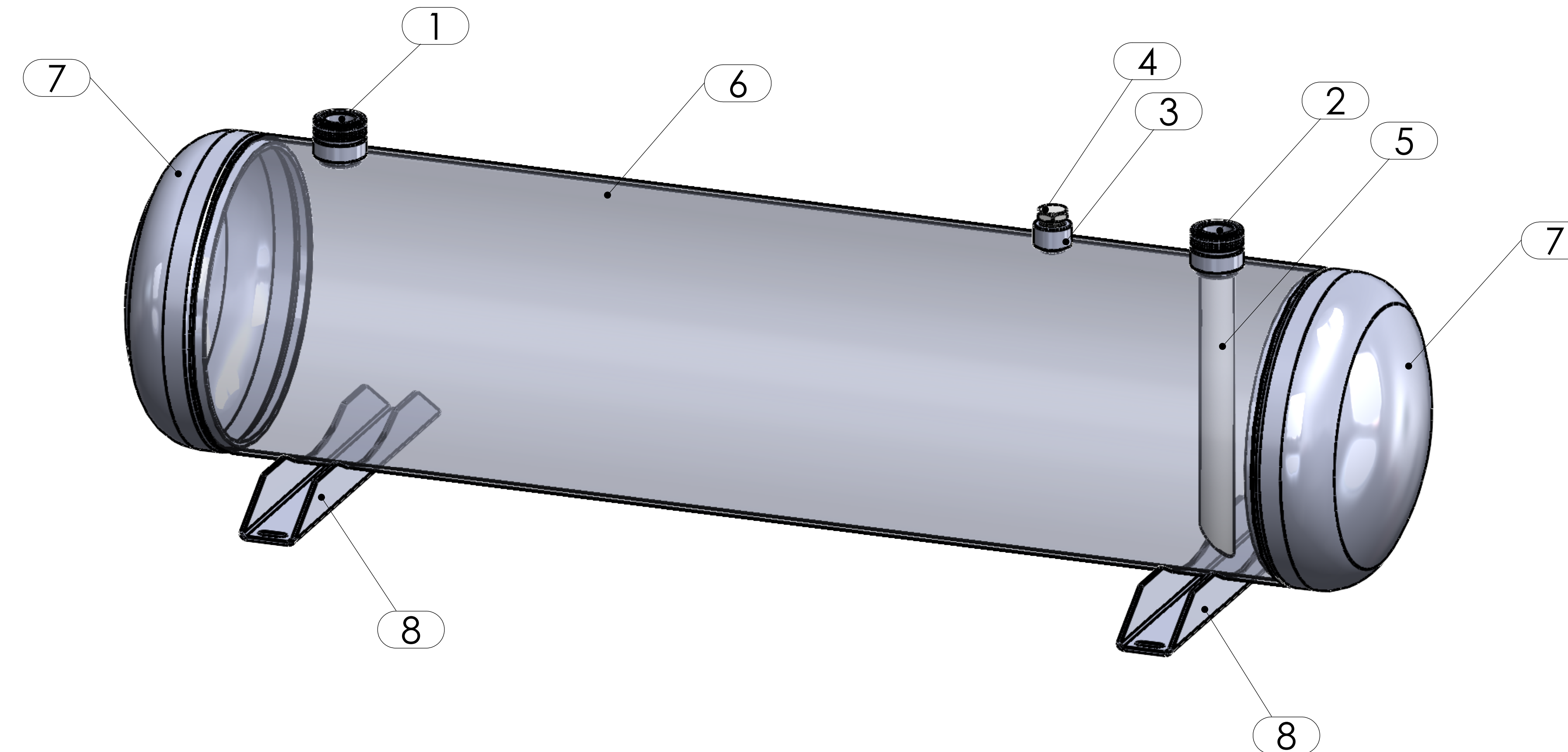

GVN STANDART PRODUCT	Customer
HORIZONTAL LIQUID RECEIVERS	Product
H8A.33b.60.A4.A4.F4	Code
	Customer Code

DESIGN DATA	
Capacity [Lt.]	60 Lt.
Design Pressure [PS]	33 Bar
Pneumatic Test Pressure [PT]	36 Bar
Hydraulic Test Pressure	48 Bar
Design Temperature [TS]	Min.-20C / Max.+130C
Cooler Fluid Type	HFC-CFC-HCFC
Fluid Group	2
Category	CAT III / H
Desing Calculation	EN 14276-1/EN 13445-3
Welded Joint Efficiency	0.85
Material Group (Shell / Head)	1.2
Testing Group	3b
Corrasion Allowance	0,5 mm
Ndt	10%
Packaging Size & Weight	00*00*00 & 00 Kg.
Drawed By	Ö.TÜRKER
Approved By	D.GÜL
Date	07.04.2022
Color	06.01.2023

MATERIAL DATA					
No	Connection	Model	Code	Qty	
1	Inlet Connection	ROT.1 3/4" H:32	106.060.A04.001.001	1	
2	Outlet Connection	ROT.1 3/4" H:32	106.060.A04.001.001	1	
3	Safety Valve Conn.	NPT 1/2" H:18	106.060.F04.000.001	1	
4	Blind Plug	NPT 1/2" Plug	106.130.F04.001.001	1	
5	Pipe	Ø28,5x1,5 H:265	104.028.015.000.265	1	
6	Shell	Ø273x4 H:970	204.H08.33B.060.001	1	
7	Head - Torispheric	Ø273x4 H:95	101.045.273.001.000	2	
8	Foot	350x50x40,5 t:3	105.002.273.001.001	2	

GENERAL NOTES	
-Max. allowable operating pressure (PS) according to the temperature range;	
1) Allowable operating temperature : min. -20C° / max. +130C° PS1 = 33 Bar	
2) Allowable operating temperature : min. -20C° / max. -40C° PS2 = 24 Bar	
-Unless otherwise specified dimensions in MM	
-Unless otherwise specified do not scale	
-Unless otherwise specified tube must be clean&free from burrs inside&outside&uitable for soldering	
-Unless otherwise specified do not scale indicated thickness are min. after forming or machining	
-Unless otherwise specified dimension tolerances according to EN 113445-4	

REVISIONS			
No	Details Of Change	Date	By
01			
02			
03			

RELATED DRAWINGS		
No	Description	Drawing No
01		
02		



No	Assembly Codes	Qty
1	M002.000037	1