

GÜVEN SOĞUTMA ÜNİTELERİ SAN. VE TİC. A.Ş.

Add.: Hastane Mah. Hadimköy İstanbul Cd. No:78/1
34555, Arnavutköy, İstanbul, TURKEY
Tel: +90 212 771 51 12 - 771 51 13
Fax: +90 212 771 51 10
www.gvn.com.tr



GVN STANDART PRODUCT

Customer

SUCTION LINE ACCUMULATORS

Product

SLA.A.45b.54.32.F4

Code

Customer Code

DESIGN DATA

Capacity [Lt.]	32 Lt.
Design Pressure [PS]	45 Bar
Pneumatic Test Pressure [PT]	50 Bar
Hydraulic Test Pressure	65 Bar
Design Temperature [TS]	Min.-20C / Max.+130C
Cooler Fluid Type	HFC-CFC-HCFC-R744
Fluid Group	2
Category	CAT III / H
Desing Calculation	EN 14276-1/EN 13445-3
Welded Joint Efficiency	0.85
Material Group (Shell / Head)	1.2
Testing Group	3b
Corrasion Allowance	0,1 mm
Ndt	10%
Packaging Size & Weight	00*00*00 & 00 Kg.
Drawed By	M.ABDULAZİZ
Approved By	D.GÜL
Date	27.05.2025
Color	RAL 5009

MATERIAL DATA

No	Connection	Model	Code	Qty
1	Inlet Connection	ODS 2 1/8" H:50	106.033.B10.INL.050	1
2	Outlet Connection	ODS 2 1/8" H:40	106.060.B10.000.012	1
3	Safety Valve Conn.	NPT 1/2" H:18	106.060.F04.NPT.T18	1
4	Blind Plug	NPT 1/2" Plug	106.130.F04.KTP.023	1
5	Shell	Ø323,9x4,5 H:245,5	204.SLA.045.324.005	1
6	Head - Torispheric	Ø323,9x4 H:105	101.045.324.001.009	1
7	Head - Torispheric	Ø324x4 H:105	101.045.324.001.000	1
8	Skirt With	Ø320x3 H:27	105.004.320.001.001	1
9	Fixing plate	107x50x3	105.107.050.001.001	1
10	Pipe	Ø51x1,5	204.051.015.SLA.007	1
11	Pipe	Ø76x1,5	204.076.015.SLA.010	1
12	Cover	Ø76x3	101.140.076.001.001	1
13	Separator		105.009.SLA.SEP.324	1

GENERAL NOTES

- Max. allowable operating pressure (PS) according to the temperature range:
- 1) Allowable operating temperature : min. -20C° / max. +130C° PS1 = 45 Bar
- 2) Allowable operating temperature : min. -40C° / max. -20C° PS2 = 33 Bar
- Unless otherwise specified do not scale
- Unless otherwise specified dimensions in MM
- Unless otherwise specified tube must be clean&free from burrs inside&outside&uitable for soldering
- Unless otherwise specified do not scale indicated thickness are min. after forming or machining
- Unless otherwise specified dimension tolerances according to EN 13445-4

REVISIONS

No	Details Of Change	Date	By
01			
02			
03			

RELATED DRAWINGS

No	Description	Drawing No
01		
02		

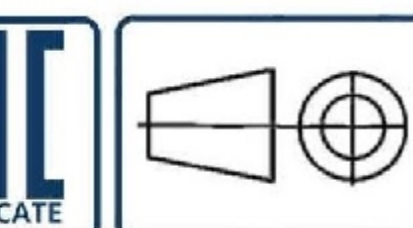

We reserve all rights in this document and in the information contained therein. Reproduction use or disclosure to third parties without express authority is strictly forbidden.

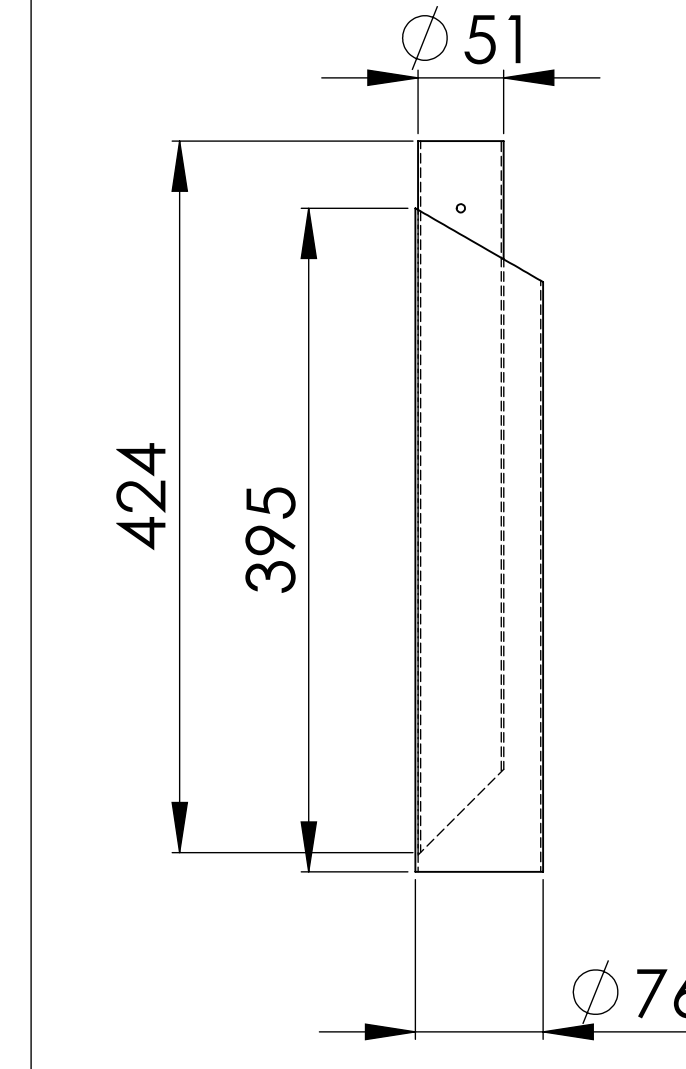
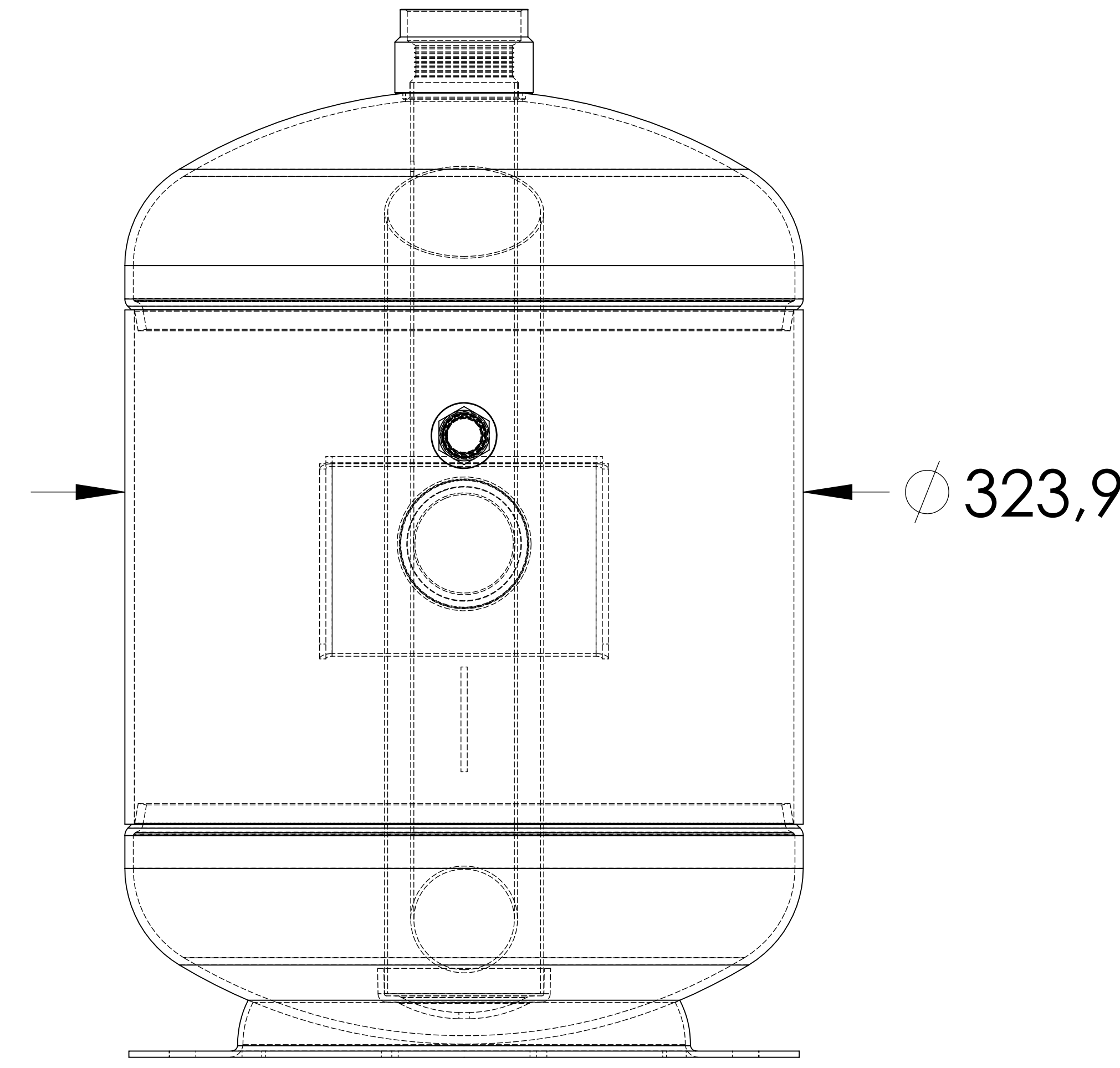
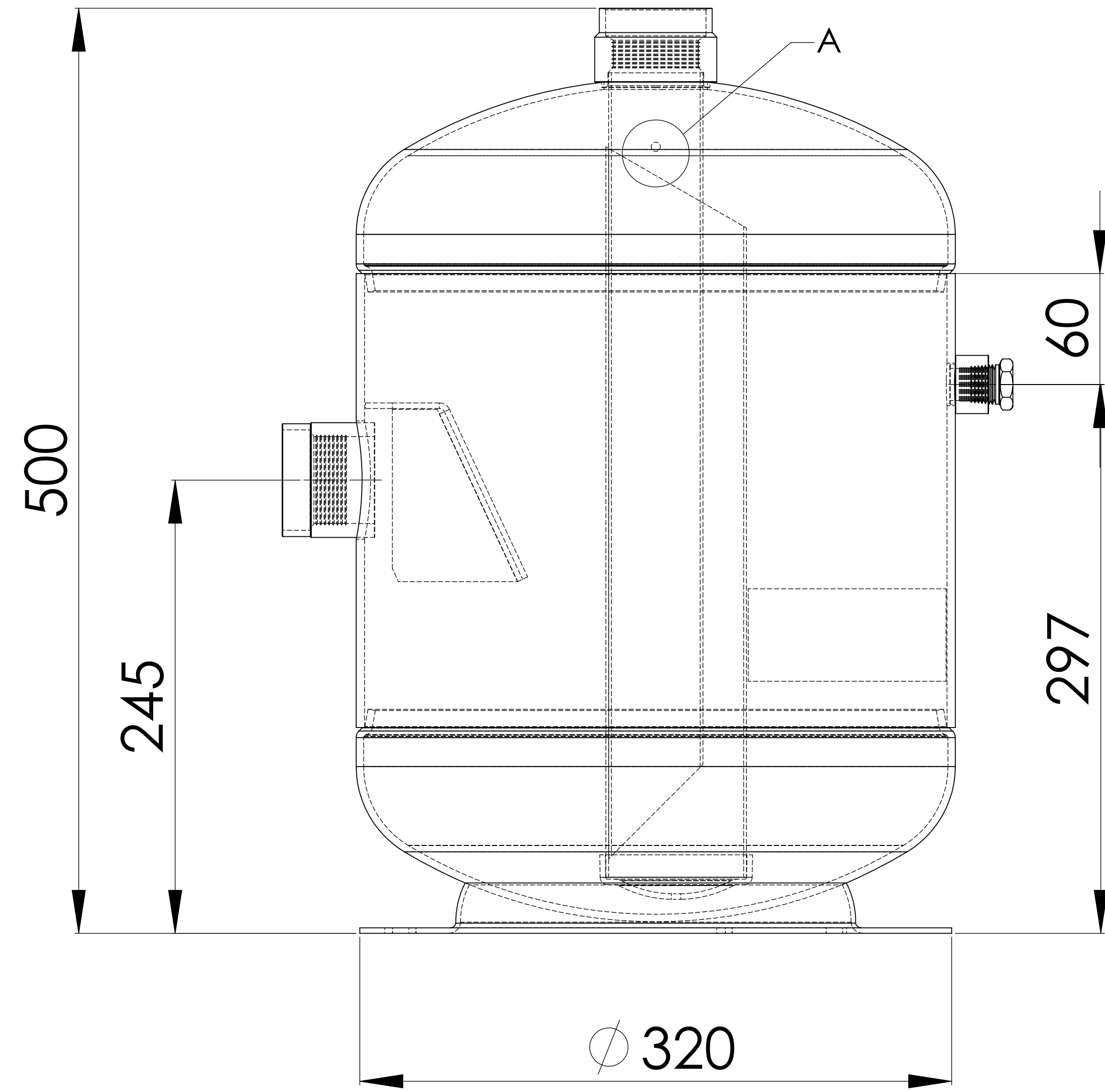

ÇIKIŞ BORUSU DETAY

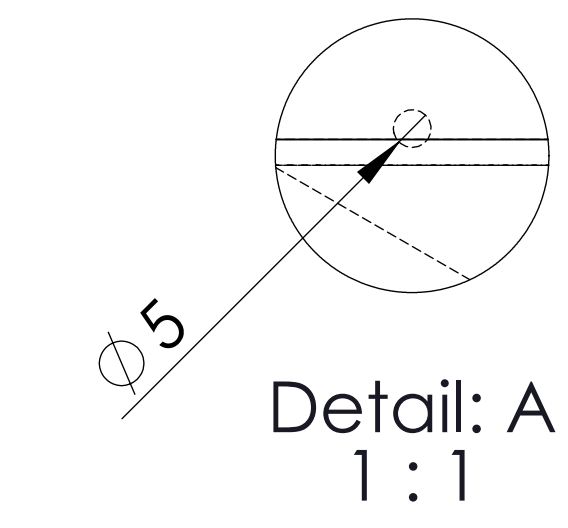

Detail: A
1:1

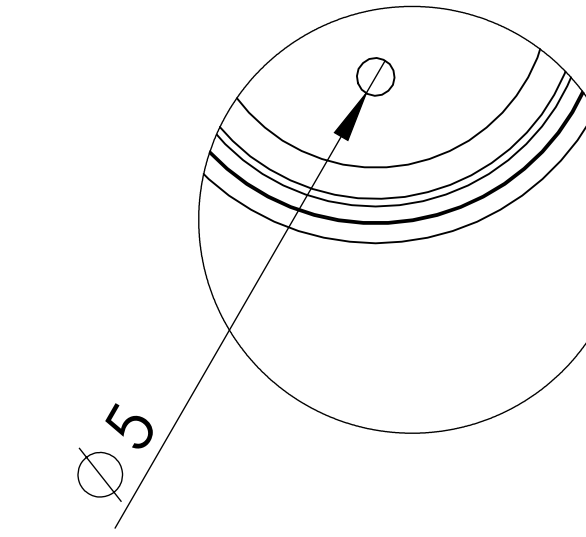

Detail: B
1:1

ÇIKIŞ BORUSU DELİK ÖLÇÜLERİ

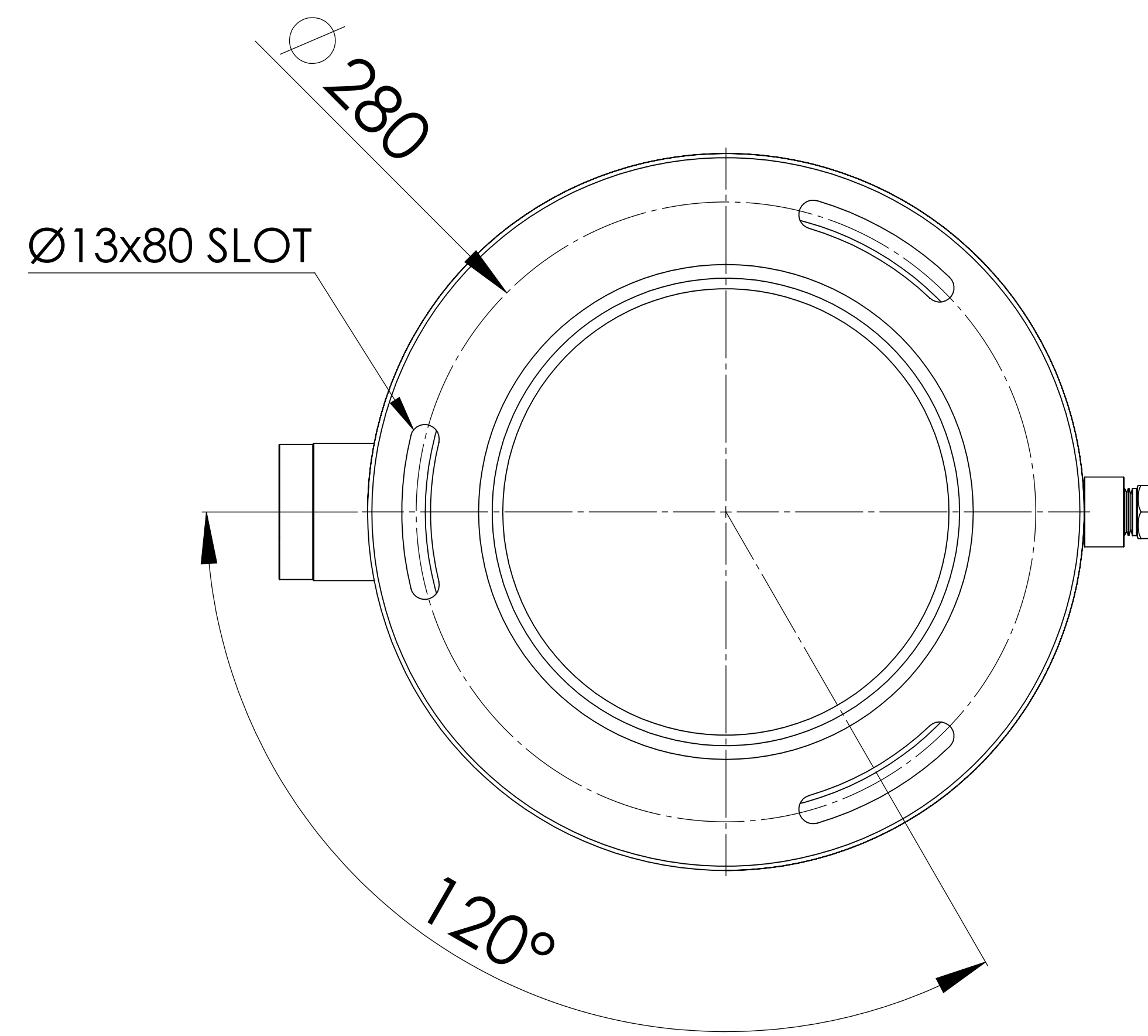

BOTTOM VIEW

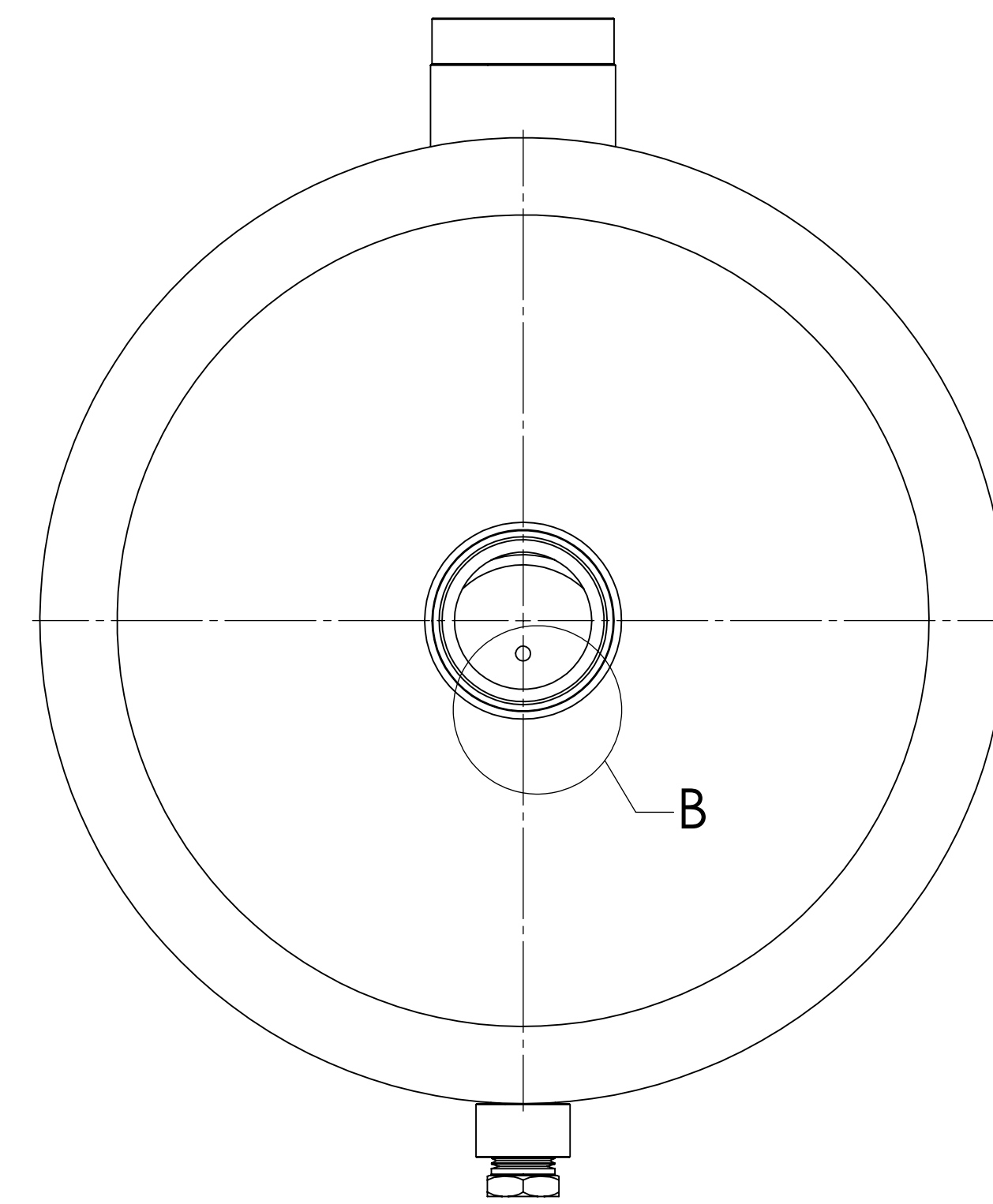

TOP VIEW

