

**GÜVEN SOĞUTMA**  
**ÜNİTELERİ SAN. VE TİC. A.Ş.**

Add: Hastane Mah. Hadimköy İstanbul Cd. No:78/1  
34555, Arnavutköy, İstanbul, TURKEY  
Tel: +90 212 771 51 12 - 771 51 13  
Fax: +90 212 771 51 10  
www.gvn.com.tr



**GVN STANDART PRODUCT**

**Customer**

**SUCTION LINE ACCUMULATORS & HEAT EXCHANGER** **Product**

**SLA.E.33B.109.22.60.F4**

**Code**

**Customer Code**

**DESIGN DATA**

Capacity [Lt.]	60 Lt.
Design Pressure [PS]	33 Bar
Pneumatic Test Pressure [PT]	36 Bar
Hydraulic Test Pressure	48 Bar
Design Temperature [TS]	Min.-20C / Max.+130C
Cooler Fluid Type	HFC-CFC-HCFC
Fluid Group	2
Category	CAT III / H
Desing Calculation	EN 14276-1/EN 13445-3
Welded Joint Efficiency	0.85
Material Group (Shell / Head)	1.2
Testing Group	3b
Corrasion Allowance	0,5 mm
Ndt	10%
Packaging Size & Weight	00*00*00 & 00 Kg.
Drawed By	Ö.TÜRKER
Approved By	D.GÜL
Date	07.12.2022
Color	RAL 5009

**MATERIAL DATA**

No	Connection	Model	Code	Qty
1	Inlet Connection	ODS 4 1/4" H:160	106.033.B18.000.002	1
2	Outlet Connection	ODS 4 1/4" H:160	106.033.B18.000.002	1
3	Heat Exchanger Inlet	ODS 7/8" H:120	106.060.B06.000.007	1
4	Heat Exchanger Outlet	ODS 7/8" H:120	106.060.B06.000.007	1
5	Safety Valve Conn.	NPT 1/2" H:18	106.060.F04.000.001	1
6	Blind Plug	NPT 1/2" Plug	106.130.F04.001.001	1
7	Exchanger Pipe	Ø22x1,5	115.022.ESJ.0ST.002	1
8	Pipe	Ø102x3	204.102.030.SLA.005	1
9	Pipe	Ø168x3	204.168.030.SLA.003	1
10	Shell	Ø406x5 H:315,5	204.SLA.033.406.007	1
11	Head Torispheric	Ø406x5 H:125	201.033.406.001.004	1
12	Head - Torispheric	Ø168x3 H:50	201.045.168.001.011	1
13	Head Torispheric	Ø406x5 H:125	101.033.406.001.000	1
14	Saparator	150x100x2	105.009.150.100.001	1

**GENERAL NOTES**

- Max. allowable operating pressure (PS) according to the temperature range;
- 1) Allowable operating temperature : min. -20C° / max. +130C° PS1 = 33 Bar
- 2) Allowable operating temperature : min. -40C° / max. -20C° PS2 = 24 Bar
- Unless otherwise specified dimensions in MM
- Unless otherwise specified do not scale
- Unless otherwise specified tube must be clean&free from burrs inside&outside&uitable for soldering
- Unless otherwise specified do not scale indicated thickness are min. after forming or machining
- Unless otherwise specified dimension tolerances according to EN 113445-4

**REVISIONS**

No	Details Of Change	Date	By
01			
02			
03			

**RELATED DRAWINGS**

No	Description	Drawing No
01		
02		

No	Assembly Codes	Qty
1	M005.000399	1

**MATERIAL DATA**

No	Connection	Model	Code	Material	Qty
15	Skirt	Ø324x5 H:50	104.045.H50.415.324	S235	1
16	Base Plate	Ø415x5	105.005.415.001.001	S235	1
17	Label Plate	120x80x2	105.006.002.120.080	DD-13	1
18	Lifting	50x50x5	105.011.MP1.050.050	S235	1

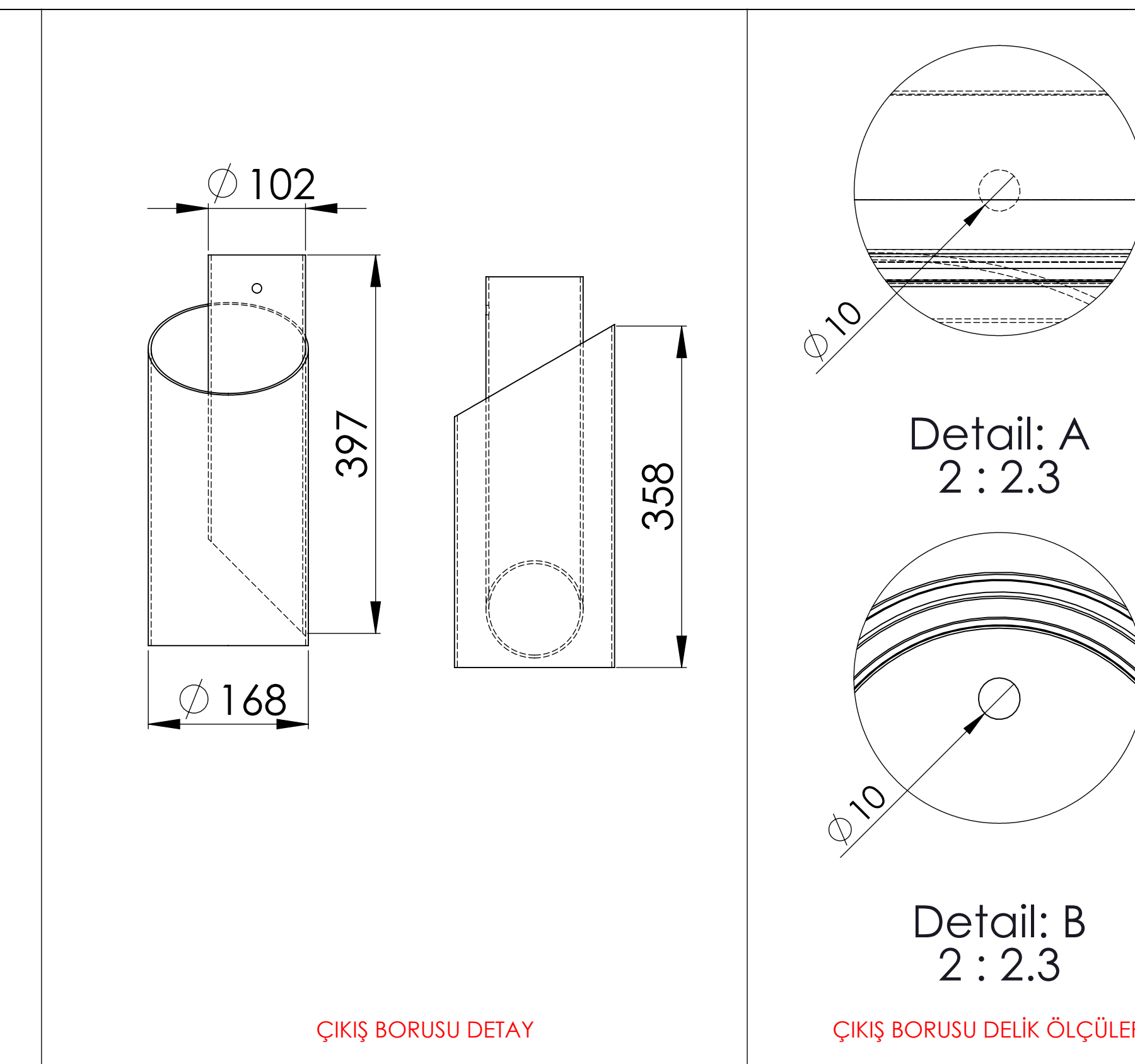

ÇIKIŞ BORUSU DETAY

ÇIKIŞ BORUSU DELİK ÖLÇÜLERİ

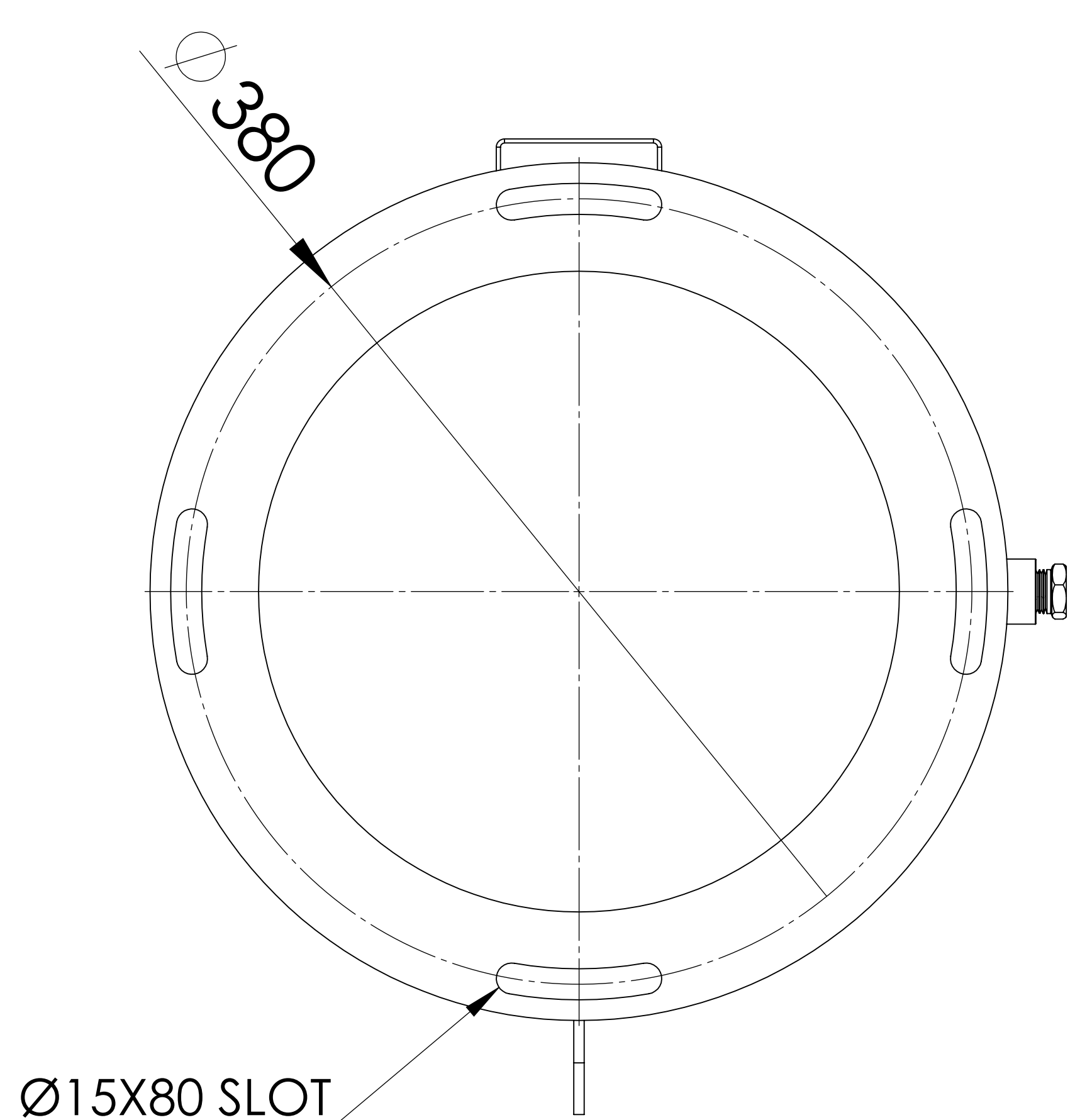
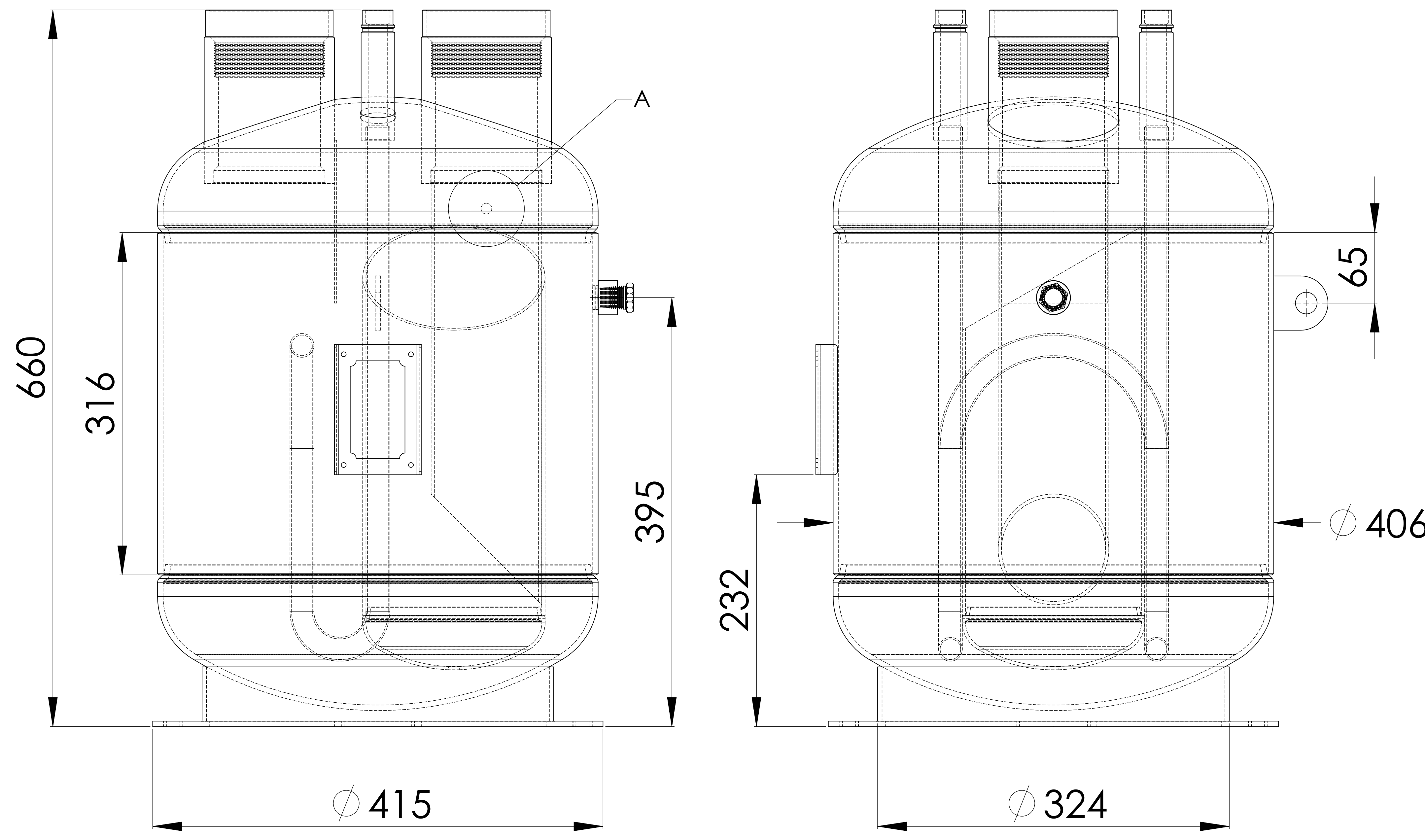

BOTTOM VIEW

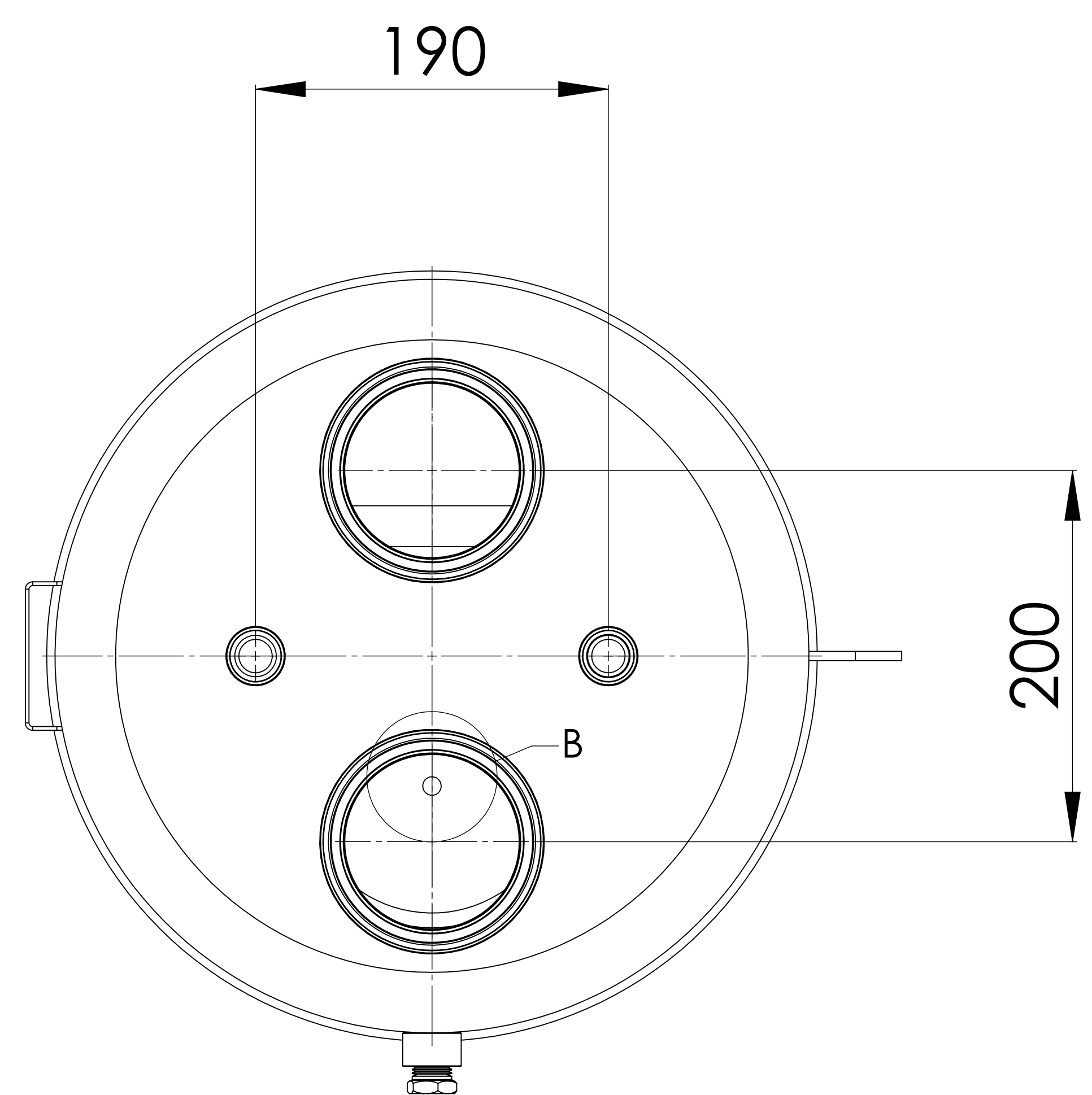

TOP VIEW

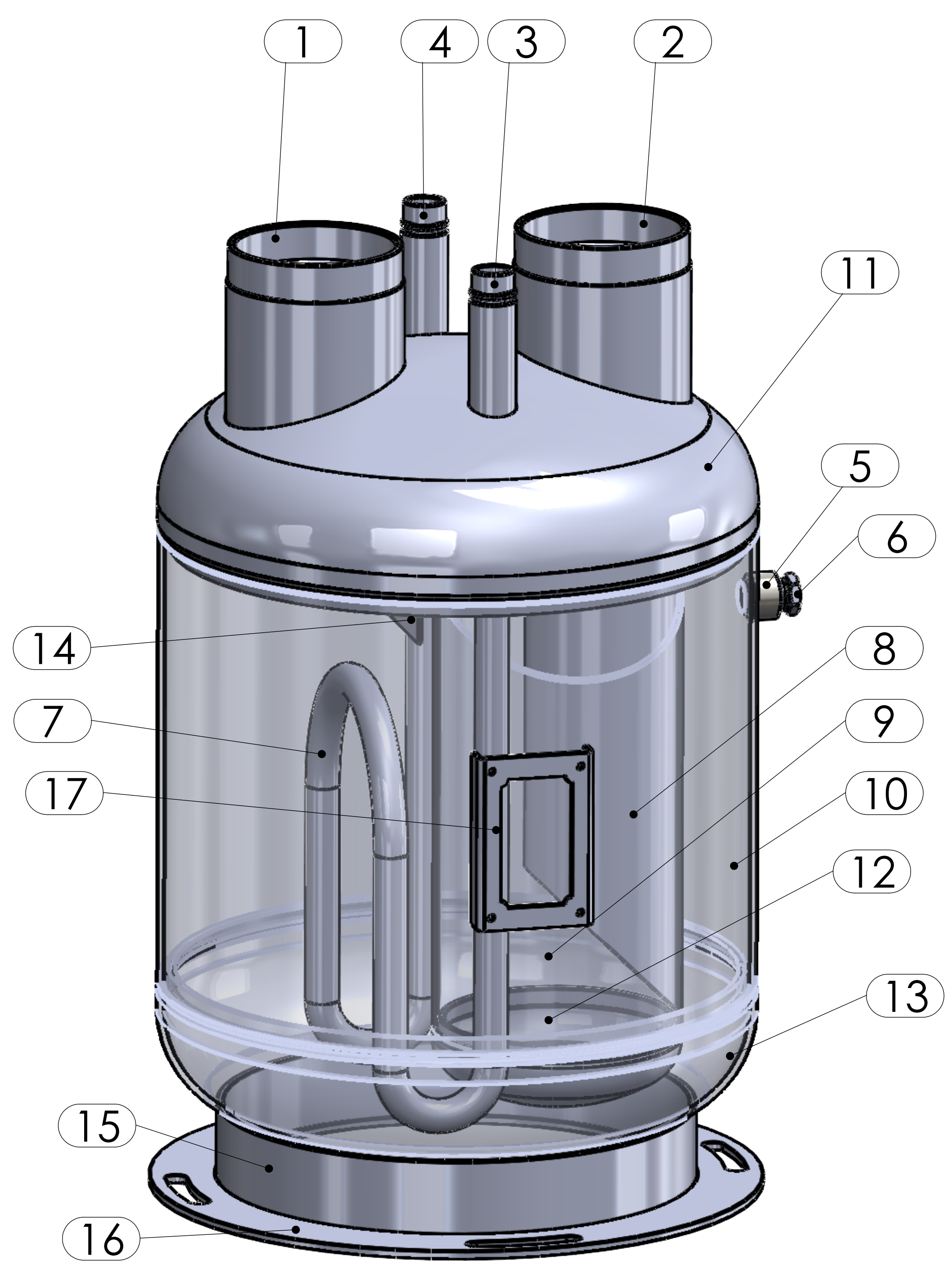

We reserve all rights in this document and in the information contained therein. Reproduction use or disclosure to third parties without express authority is strictly forbidden.