

KESIT A-A
ÖLÇEK 1:0.8

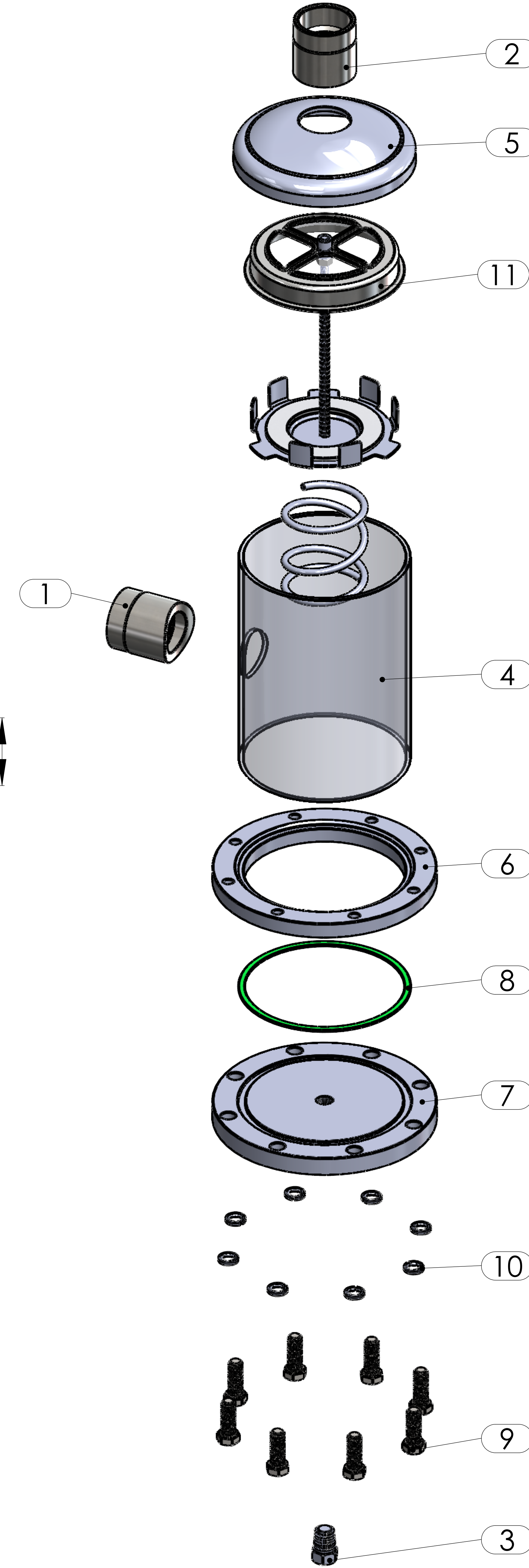
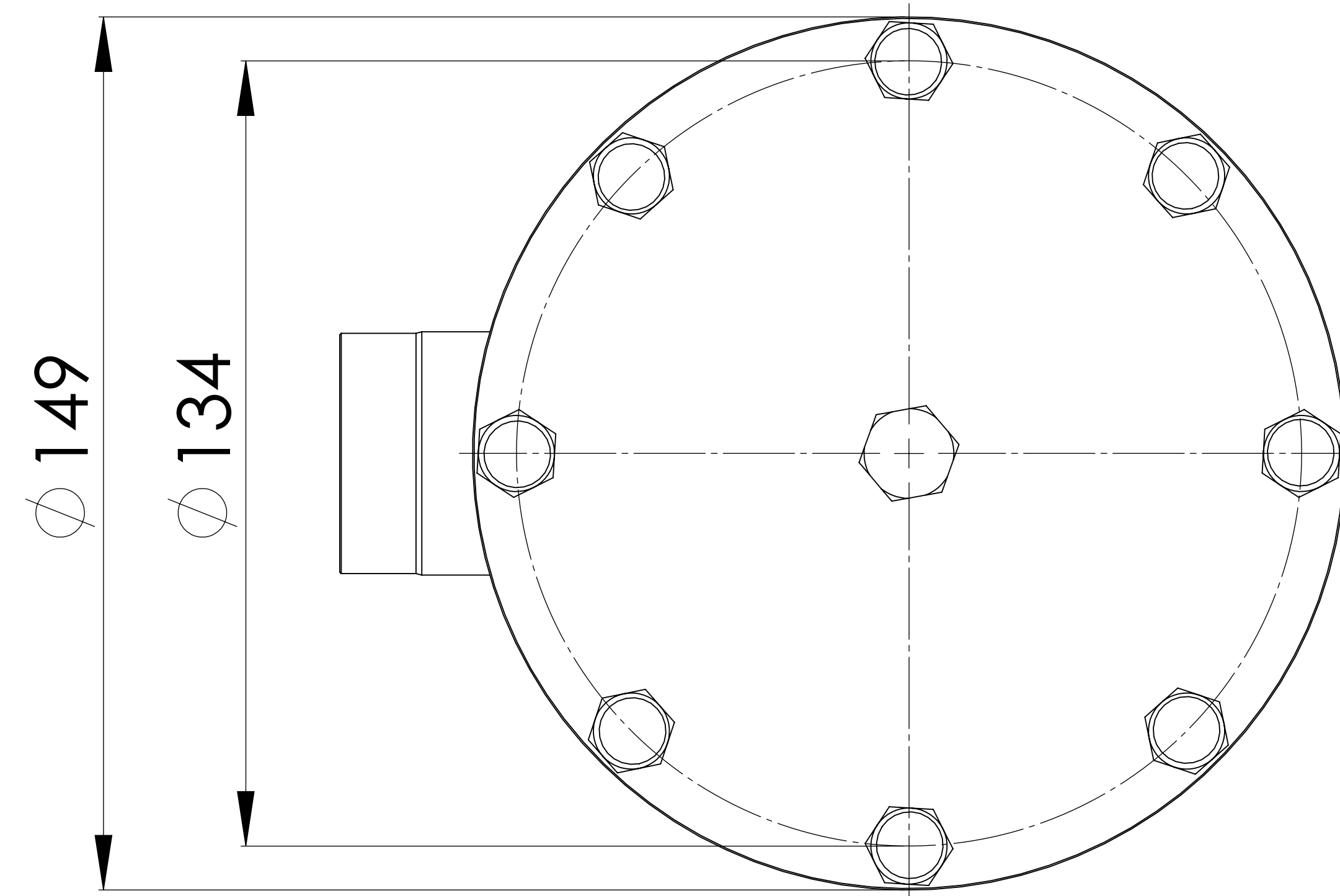

No	Assembly Codes	Qty
1	M006.000077	1
2	M012.000032	1

GÜVEN SOĞUTMA ÜNİTELERİ SAN. VE TİC. A.Ş.

Add.: Hastane Mah. Hadimköy İstanbul Cd. No:78/1
34555, Arnavutköy, İstanbul, TURKEY
Tel: +90 212 771 51 12 - 771 51 13
Fax: +90 212 771 51 10
www.gvn.com.tr



GVN STANDART PRODUCT

Customer

FILTER DRIER SHELLS

Product

H48.45B.35.1

Code

Customer Code

DESIGN DATA

Capacity [Lt.]	1,6 Lt.
Design Pressure [PS]	45 Bar
Pneumatic Test Pressure [PT]	50 Bar
Hydraulic Test Pressure	65 Bar
Design Temperature [TS]	Min.-20C / Max.+130C
Cooler Fluid Type	HFC-CFC-HCFC-R744
Fluid Group	2
Category	CAT I / A
Desing Calculation	EN 14276-1/EN 13445-3
Welded Joint Efficiency	0.85
Material Group (Shell / Head)	1.2
Testing Group	3b
Corrasion Allowance	0,5 mm
Ndt	10%
Packaging Size & Weight	00*00*00 & 00 Kg.
Drawed By	Ö.TÜRKER
Approved By	D.GÜL
Date	13.04.2023
Color	RAL 5009

MATERIAL DATA

No	Connection	Model	Code	Material	Qty
1	Inlet Connection	ODS 1 3/8" H:54	106.060.B08.000.018	E275	1
2	Outlet Connection	ODS 1 3/8" H:40	106.060.B08.000.001	E275	1
3	Blind Plug	NPT 1/4"Plug	106.130.F02.001.001	S235	1
4	Shell	Ø114,3x3 H:156	204.H48.045.035.001	P355NH EN 10217-3	1
5	Head	Ø114x4 H:31	202.045.114.H48.004	P355GH-EN10028-2	1
6	Bottom Flange	Ø149X13	107.045.H48.114.002	P355GH+N	1
7	Top Flange	Ø149X13	107.045.H48.114.001	P355GH+N	1
8	Klingerite Gasket	(Ø114,5-Ø106,5)	108.114.106.000.K01	ASBESTOS FREE GP-150 AFM30-40C	1
9	Bolt	M8X25	109.080.025.088.C01	8.8	8
10	Washer	M8	109.080.000.000.R01		8
11	Filter holder		M012.000032		1

GENERAL NOTES

- Max. allowable operating pressure (PS) according to the temperature range;
- 1) Allowable operating temperature : min. -20C° / max. +130C° PS1 = 45 Bar
- 2) Allowable operating temperature : min. -40C° / max. -20C° PS2 = 33 Bar
- Unless otherwise specified do not scale
- Unless otherwise specified tube must be clean&free from burrs inside&outside&uitable for soldering
- Unless otherwise specified do not scale indicated thickness are min. after forming or machining
- Unless otherwise specified dimension tolerances according to EN 113445-4

REVISIONS

No	Details Of Change	Date	By
01			
02			
03			

RELATED DRAWINGS

No	Description	Drawing No
01		
02		



We reserve all rights in this document and in the information contained therein. Reproduction use or disclosure to third parties without express authority is strictly forbidden.