

KESİT A-A
ÖLÇEK 1 : 0.8

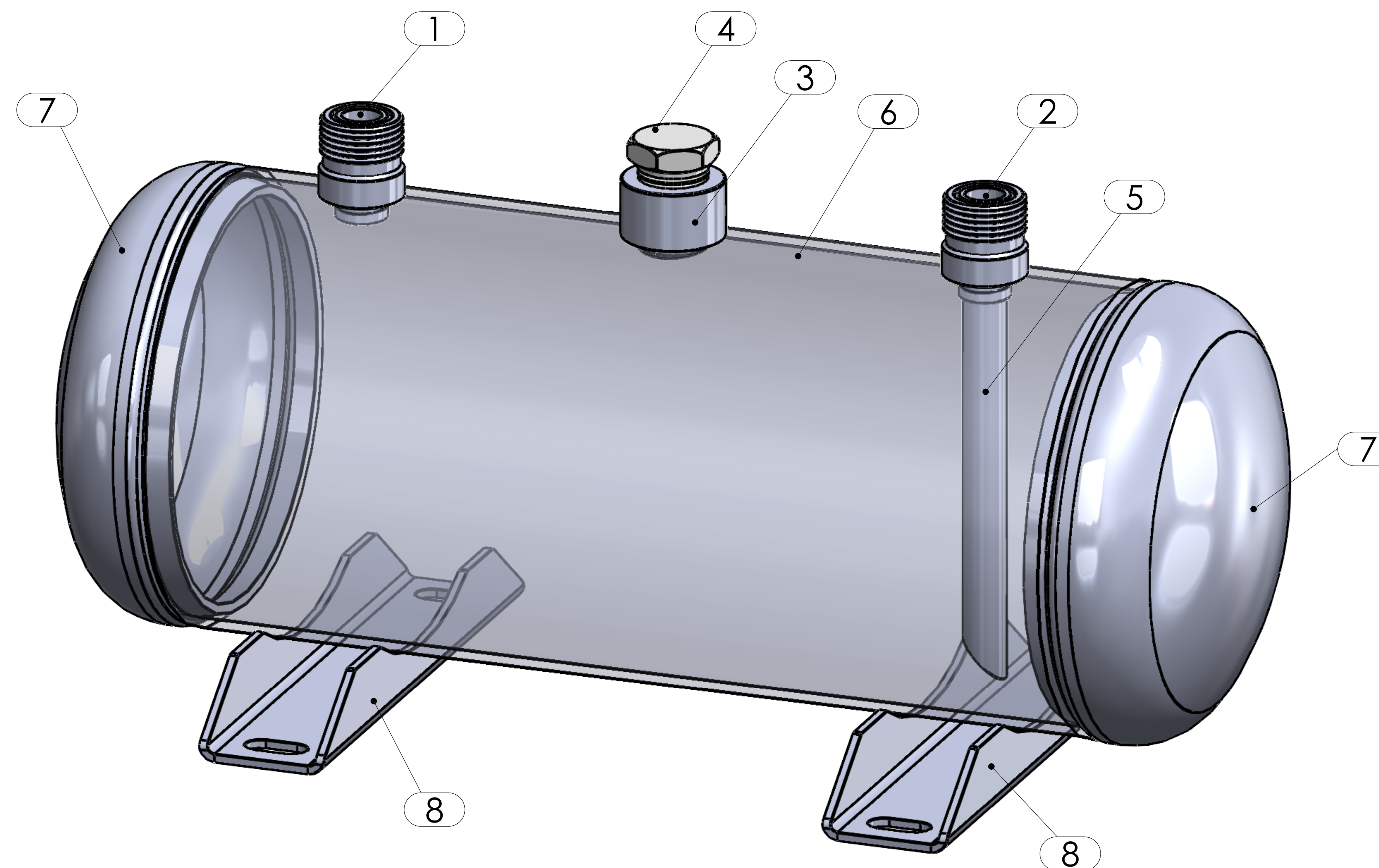

GVN STANDART PRODUCT

Customer

HORIZONTAL LIQUID RECEIVERS

Product

H5A.33b.05.A2.A2.F4

Code

Customer Code

DESIGN DATA

| | |
|-------------------------------|-----------------------|
| Capacity [Lt.] | 5 Lt. |
| Design Pressure [PS] | 33 Bar |
| Pneumatic Test Pressure [PT] | 36 Bar |
| Hydraulic Test Pressure | 48 Bar |
| Design Temperature [TS] | Min.-20C / Max.+130C |
| Cooler Fluid Type | HFC-CFC-HCFC |
| Fluid Group | 2 |
| Category | CAT I / A |
| Desing Calculation | EN 14276-1/EN 13445-3 |
| Welded Joint Efficiency | 0.85 |
| Material Group (Shell / Head) | 1.2 |
| Testing Group | 3b |
| Corrasion Allowance | 0,5 mm |
| Ndt | 10% |
| Packaging Size & Weight | 00*00*00 & 00 Kg. |
| Drawed By | Ö.TÜRKER |
| Approved By | D.GÜL |
| Date | 04.01.2023 |
| Color | RAL 5009 |

MATERIAL DATA

| No | Connection | Model | Code | Material | Qty |
|----|--------------------|---------------|---------------------|---------------------|-----|
| 1 | Inlet Connection | ROT. 1" H:25 | 106.060.A02.001.001 | E275-ST44 | 1 |
| 2 | Outlet Connection | ROT. 1" H:25 | 106.060.A02.001.001 | E275-ST44 | 1 |
| 3 | Safety Valve Conn. | NPT 1/2" H:18 | 106.060.F04.000.001 | E275-ST44 | 1 |
| 4 | Blind Plug | NPT 1/2" Plug | 106.130.F04.001.001 | E275 | 1 |
| 5 | Pipe | Ø13x1 H:128 | 104.013.010.000.128 | E235 | 1 |
| 6 | Shell | 139,7x3 H:290 | 204.H05.60B.005.001 | EN10217-3 P355NH | 1 |
| 7 | Head - Torispheric | Ø140x3 H:45 | 101.060.140.001.000 | EN10028-2 P355GH | 2 |
| 8 | Foot | 170x40x25 t:3 | 105.002.140.001.001 | DD13- EN10111 | 2 |

GENERAL NOTES

- Max. allowable operating pressure [PS] according to the temperature range;
- 1) Allowable operating temperature : min. -20C° / max. +130C° PS1 = 33 Bar
- 2) Allowable operating temperature : min. -20C° / max. -40C° PS2 = 24 Bar
- Unless otherwise specified dimensions in MM
- Unless otherwise specified do not scale
- Unless otherwise specified tube must be clean&free form burrs inside&outside&uitable for soldering
- Unless otherwise specified do not scale indicated thickness are min. after forming or machining
- Unless otherwise specified dimension tolerances according to EN 113445-4

REVISIONS

| No | Details Of Change | Date | By |
|----|-------------------|------|----|
| 01 | | | |
| 02 | | | |
| 03 | | | |

RELATED DRAWINGS

| No | Description | Drawing No |
|----|-------------|------------|
| 01 | | |
| 02 | | |

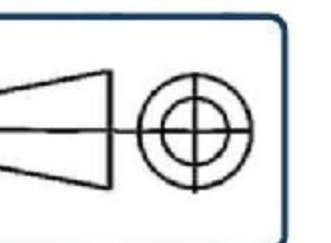

| No | Assembly Codes | Qty |
|----|----------------|-----|
| 1 | M002.000017 | 1 |