

**STANDARD PRODUCTION** **Customer**

**HORIZONTAL LIQUID RECEIVERS & BASEPLATE** **Product**

**HC9.33b.90.A4.A4.F4** **Code**

**Customer Code**

**DESIGN DATA**

Capacity [Lt.]	90 Lt.
Design Pressure [PS]	33 Bar
Pneumatic Test Pressure [PT]	36 Bar
Hydraulic Test Pressure	48 Bar
Design Temperature [TS]	Min.-20C / Max.+130C
Cooler Fluid Type	HFC-CFC-HCFC
Fluid Group	2
Category	CAT III / H
Desing Calculation	EN 14276-1/EN 13445-3
Welded Joint Efficiency	0.85
Material Group (Shell / Head)	1.2
Testing Group	3b
Corrasion Allowance	0,5 mm
Ndt	10%
Packaging Size & Weight	00*00*00 & 00 Kg.
Drawed By	İ.TOMBUL
Approved By	D.GÜL
Date	13.04.2022
Color	RAL 5009

**MATERIAL DATA**

No	Connection	Model	Code	Material	Qty
1	Inlet Connection	ROT.1 3/4" H:32	106.060.A04.001.001	E 275	1
2	Outlet Connection	ROT.1 3/4" H:32	106.060.A04.001.001	E 275	1
3	Safety Valve Conn.	NPT 1/2" H:18	106.060.F04.000.001	E275-ST44	1
4	Blind Plug	NPT 1/2" Plug	106.130.F04.001.001	E275	1
5	Pipe	Ø28,5x1,5 H:314	104.028.015.000.314	E235	1
6	Shell	Ø324x4	204.HC9.33B.090.001	P355NH-EN10217-3	1
7	Head - Torispheric	Ø323,9x4 H:100	101.033.324.001.000	P355GH EN 10028-2	2
8	Foot	400x50x50,6 t:3	105.002.324.001.001	EN10111-DD13	2
9	BasePlate	Ø324 - 570x360x3	105.007.324.570.360	ST37	1
10	Lifting	50x50x5	105.011.MPO.050.050	S235	2
11	Label Plate	120x80x2	105.006.002.120.080	DD-13	1

**GENERAL NOTES**

-Max. allowable operating pressure (PS) according to the temperature range;  
 1) Allowable operating temperature : min. -20C° / max. +130C° PS1 = 33 Bar  
 2) Allowable operating temperature : min. -20C° / max. -40C° PS2 = 24 Bar  
 -Unless otherwise specified dimensions in MM  
 -Unless otherwise specified do not scale  
 -Unless otherwise specified tube must be clean&free from burrs inside&outside&suitable for soldering  
 -Unless otherwise specified do not scale indicated thickness are min. after forming or machining  
 -Unless otherwise specified dimension tolerances according to EN 113445-4

**REVISIONS**

No	Details Of Change	Date	By
01	Ölçüsel değişiklik olmadı, görsellerin konum düzenlemeleri yapıldı.	25.10.2022	Ö.TÜRKER
02			
03			

**RELATED DRAWINGS**

No	Description	Drawing No
01		
02		

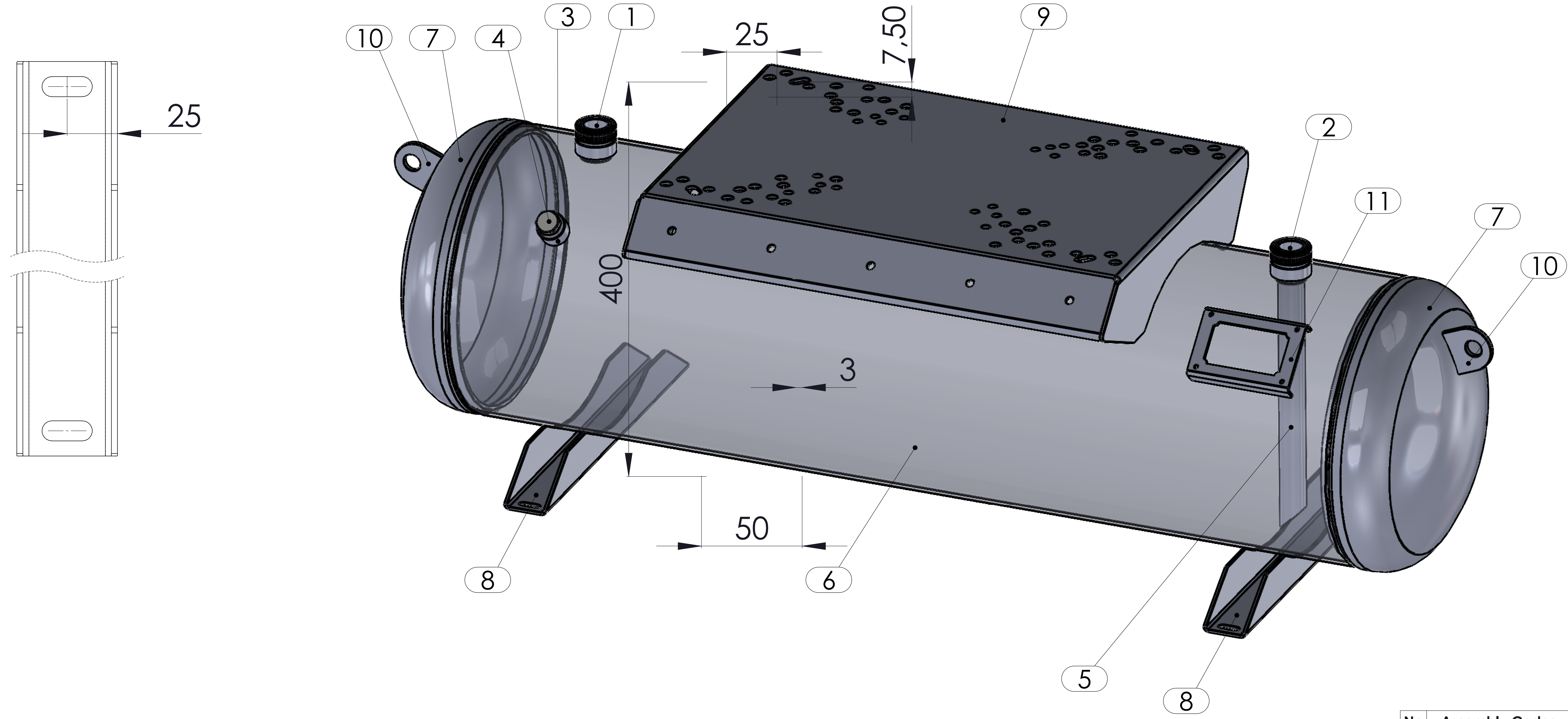

No	Assembly Codes	Qty
1	M002.000083	1



We reserve all rights in this document and in the information contained therein. Reproduction use or disclosure to third parties without express authority is strictly forbidden.