

GVN STANDART PRODUCT **Customer**

HORIZONTAL LIQUID RECEIVER **Product**

HLR.A.30b.05.B2.C2 **Code**

Customer Code

DESIGN DATA

Capacity [Lt.]	5 Lt.
Design Pressure [PS]	30 Bar
Pneumatic Test Pressure [PT]	33 Bar
Hydraulic Test Pressure	43 Bar
Design Temperature [TS]	Min.-20C / Max.+130C
Cooler Fluid Type	HFC-CFC-HCFC
Fluid Group	2
Category	CAT I / A
Desing Calculation	EN 14276-1/EN 13445-3
Welded Joint Efficiency	0.85
Material Group (Shell / Head)	1.2
Testing Group	3b
Corrasion Allowance	0,5 mm
Ndt	10%
Packaging Size & Weight	00*00*00 & 00 Kg.
Drawed By	Ö.TÜRKER
Approved By	D.GÜL
Date	04.01.2023
Color	RAL 5009

MATERIAL DATA

No	Connection	Model	Code	Material	Qty
1	Inlet Connection	ODS 3/8" H:30	106.060.B02.000.004	ST44-E275	1
2	Outlet Connection	ROT. 1" H:25	106.060.A02.001.001	E275-ST44	1
3	Outlet Valve	RV.45b-3/8	-RVA 1		1
4	Deep Drawn	Ø160x2,5 H:145	203.050.002.002.001	EN10111-DD13	1
5	Deep Drawn	Ø160x2,5 H:145	203.050.001.002.001	EN10111-DD13	1
6	Pipe	Ø13x1 H:148	104.013.010.000.148	E235	1
7	Base Plate	80x80x3	105.001.160.001.001	1.0037 (S235JR)	2

GENERAL NOTES

-Max. allowable operating pressure (PS) according to the temperature range;
 1) Allowable operating temperature : min. -20C° / max. +130C° PS1 = 30 Bar
 2) Allowable operating temperature : min. -20C° / max. -40C° PS2 = 22 Bar
 -Unless otherwise specified dimensions in MM
 -Unless otherwise specified do not scale
 -Unless otherwise specified tube must be clean&free form burrs inside&outside&uitable for soldering
 -Unless otherwise specified do not scale indicated thickness are min. after forming or machining
 -Unless otherwise specified dimension tolerances according to EN 113445-4

REVISIONS

No	Details Of Change	Date	By
01			
02			
03			

RELATED DRAWINGS

No	Description	Drawing No
01		
02		



We reserve all rights in this document and in the information contained therein. Reproduction use or disclosure to third parties without express authority is strictly forbidden.

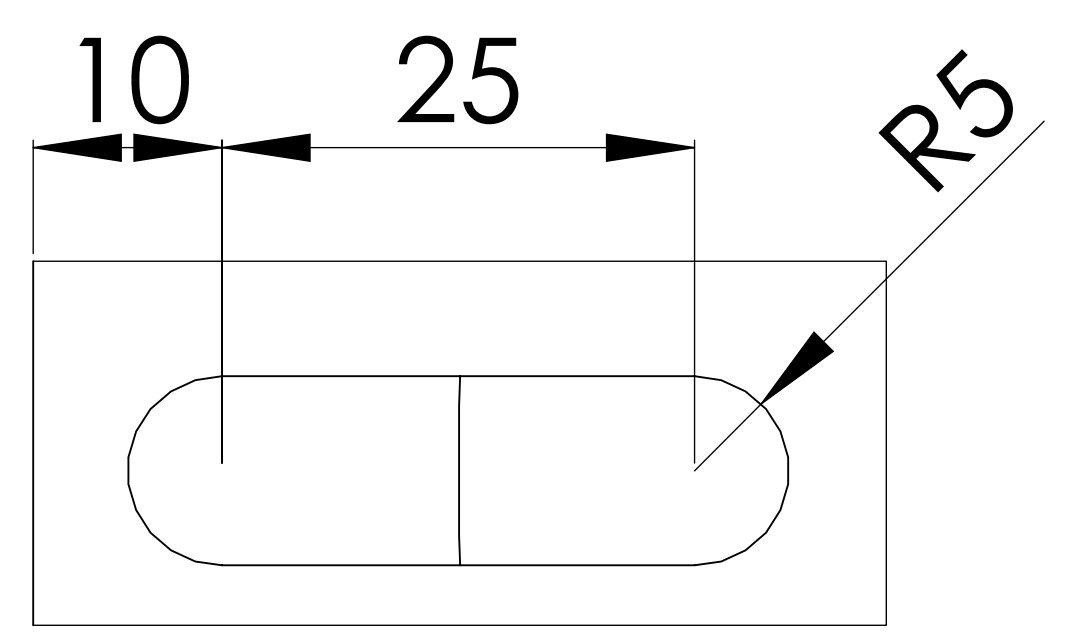
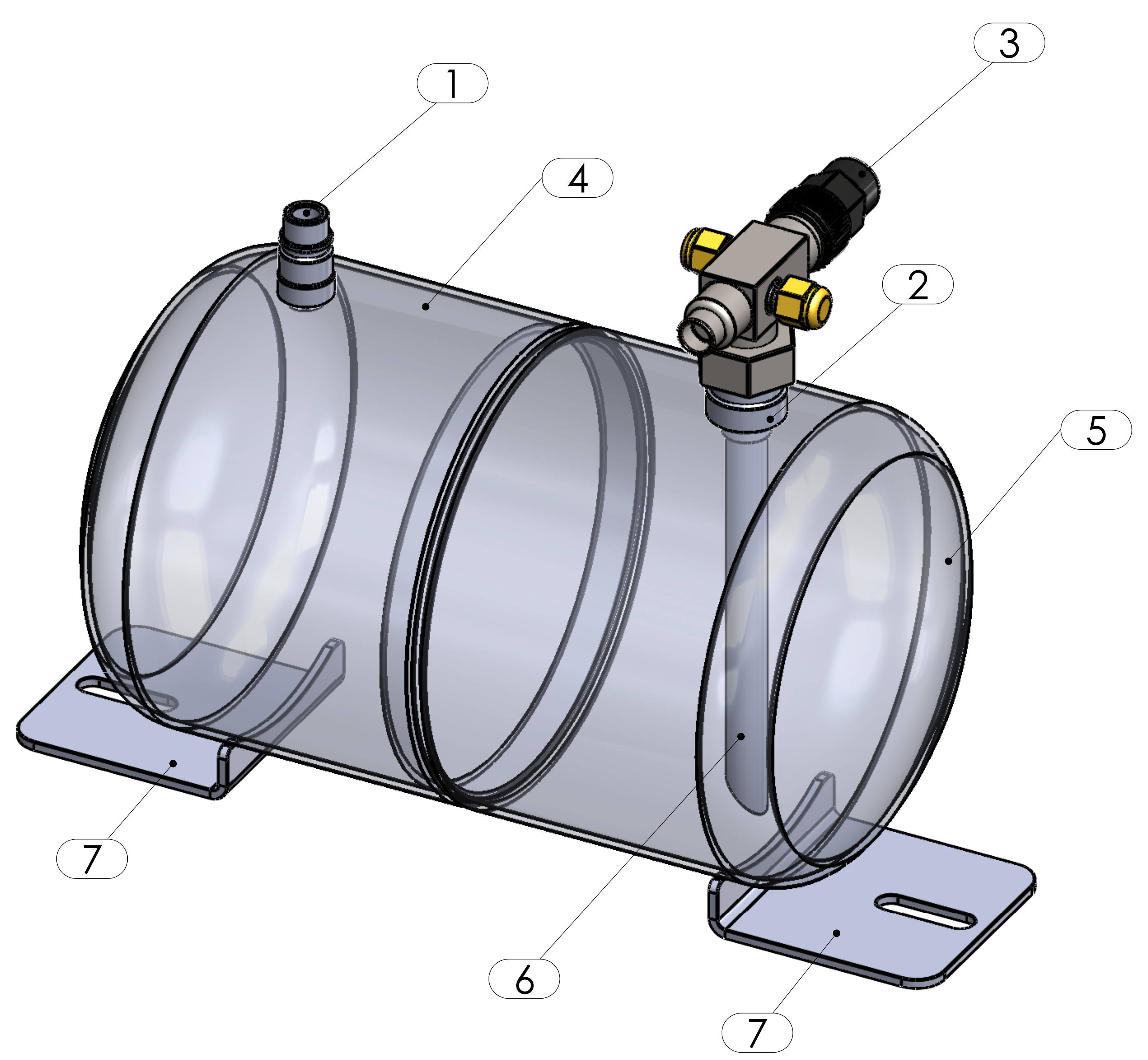
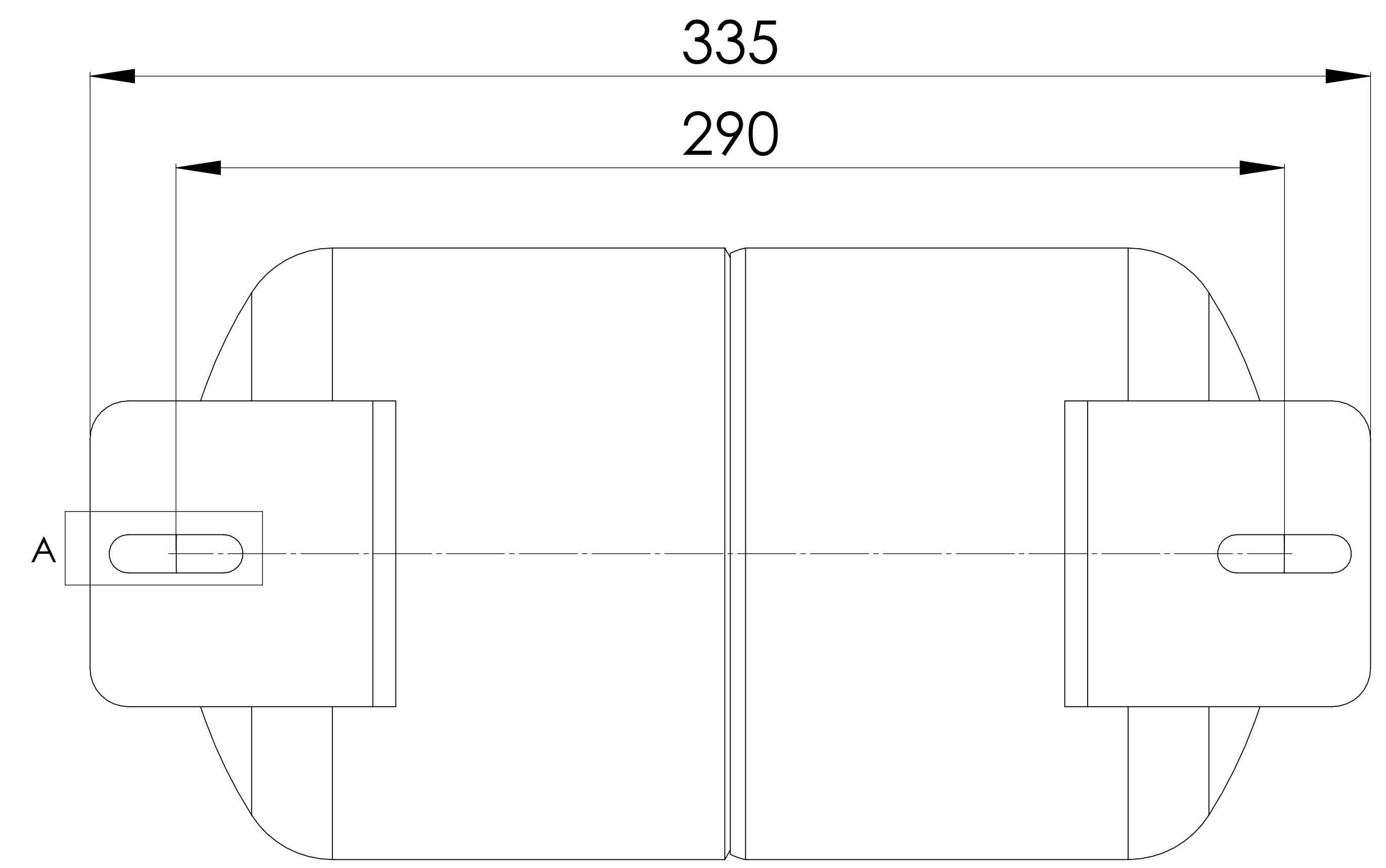
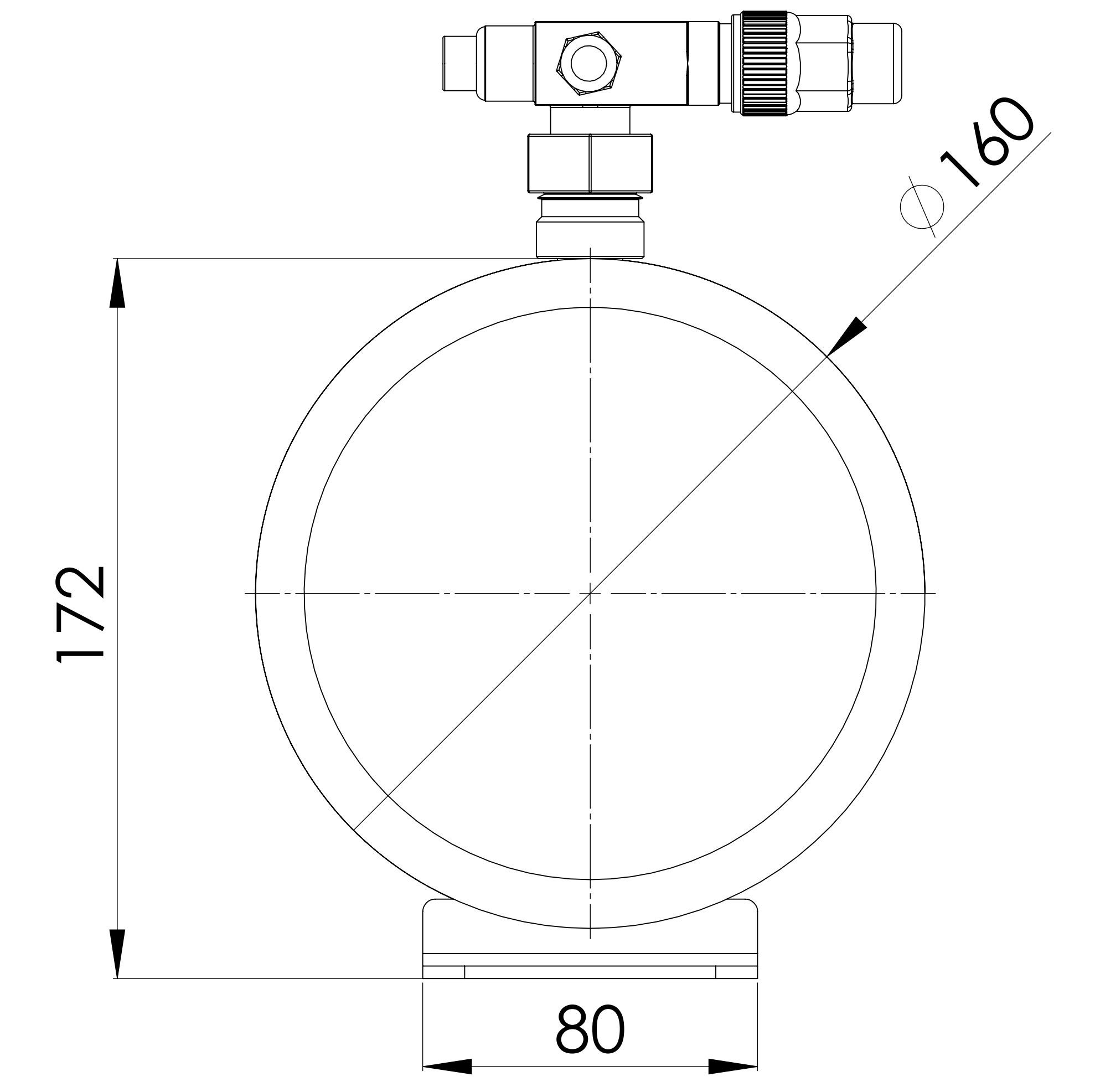
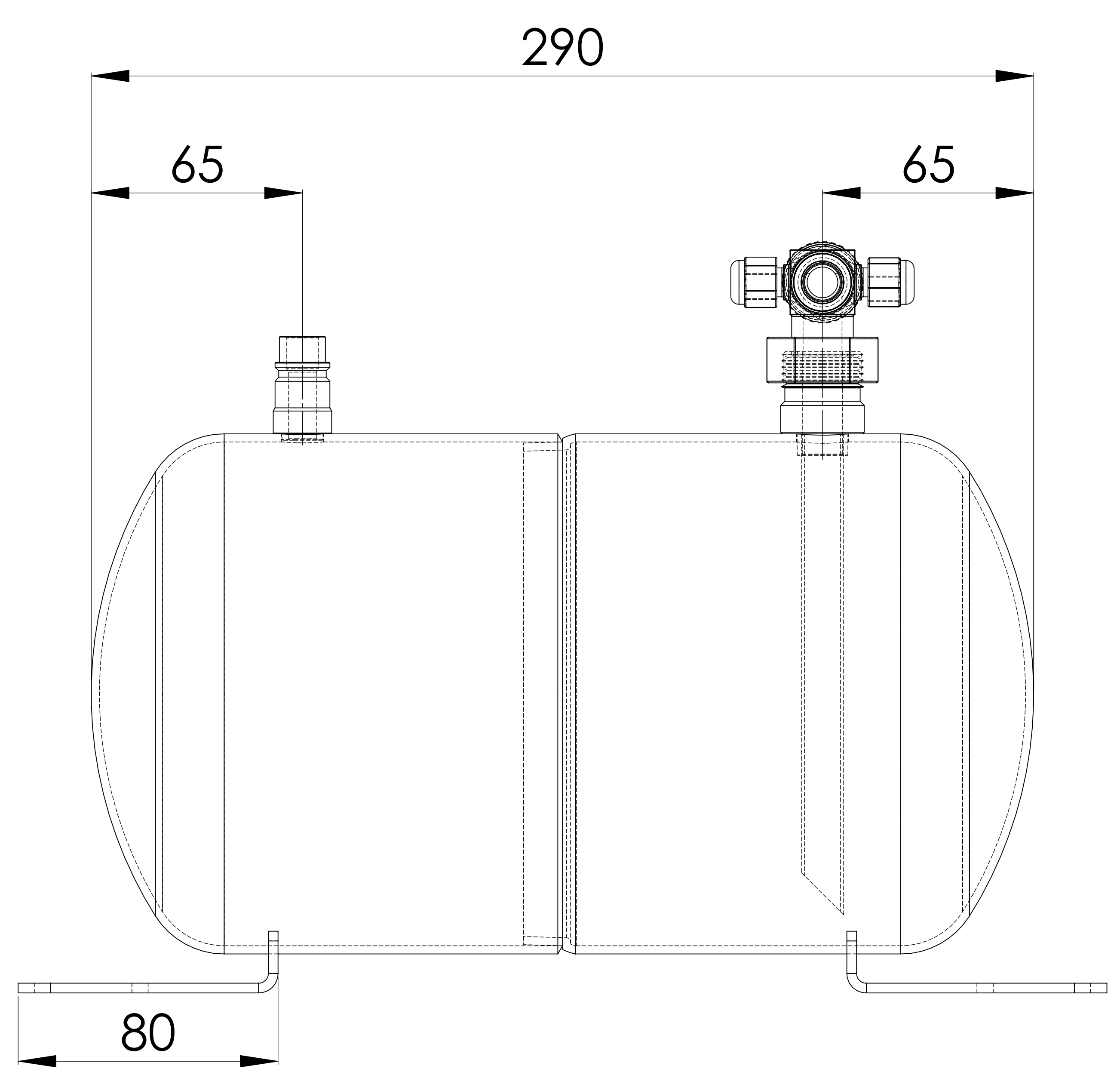

Detail: A

No	Assembly Codes	Qty
1	M002.000005	1