

GVN STANDART PRODUCT

Customer

UNIVERSAL LIQUID RECEIVERS

Product

HV7.33b.30.A3.A3.F4

Code

Customer Code

DESIGN DATA

Capacity [Lt.]	30 Lt.
Design Pressure [PS]	33 Bar
Pneumatic Test Pressure [PT]	36 Bar
Hydraulic Test Pressure	48 Bar
Design Temperature [TS]	Min.-20C / Max.+130C
Cooler Fluid Type	HFC-CFC-HCFC
Fluid Group	2
Category	CAT II / D1
Desing Calculation	EN 14276-1/EN 13445-3
Welded Joint Efficiency	0.85
Material Group (Shell / Head)	1.2
Testing Group	3b
Corrasion Allowance	0,5 mm
Ndt	10%
Packaging Size & Weight	00*00*00 & 00 Kg.
Drawed By	Ö.TÜRKER
Approved By	D.GÜL
Date	25.04.2022
Color	RAL 5009

MATERIAL DATA

No	Connection	Model	Code	Material	Qty
1	Inlet Connection	ROT. 1 1/4" H:27	106.060.A03.001.001	E275	1
2	Outlet Connection	ROT. 1 1/4" H:27	106.060.A03.001.001	E275	1
3	Safety Valve Conn.	NPT 1/2" H:18	106.060.F04.000.001	E275-ST44	1
4	Blind Plug	NPT 1/2" Plug	106.130.F04.001.001	E275	1
5	Pipe	RV,MNS 1 1/4" Ø19x1,5	204.B19.015.219.150	E235	1
6	Shell	Ø219x3 H:746	204.HV7.33B.030.001	EN10217-3 P355NH	1
7	Head - Torispheric	Ø219x3 H:75	201.033.219.001.002	EN 10028-2 P355GH	1
8	Head Torispheric	Ø219x3 H:75	101.033.219.001.000	EN10028-2 P355GH	1
9	Skirt With	Ø205x2,5 H:18	105.004.205.001.001	S235JR	1
10	Foot	260x40x31,5 t:3	105.002.219.001.001	EN10111-DD13	2

GENERAL NOTES

-Max. allowable operating pressure (PS) according to the temperature range;
 1) Allowable operating temperature : min. -20C° / max. +130C° PS1 = 33 Bar
 2) Allowable operating temperature : min. -20C° / max. -40C° PS2 = 24 Bar
 -Unless otherwise specified dimensions in MM
 -Unless otherwise specified do not scale
 -Unless otherwise specified tube must be clean&free form burrs inside&outside&uitable for soldering
 -Unless otherwise specified do not scale indicated thickness are min. after forming or machining
 -Unless otherwise specified dimension tolerances according to EN 113445-4

REVISIONS

No	Details Of Change	Date	By
01			
02			
03			

RELATED DRAWINGS

No	Description	Drawing No
01		
02		

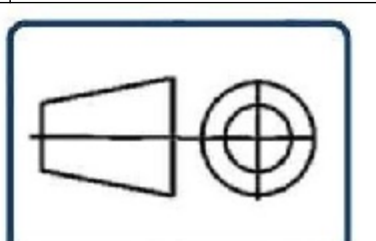

We reserve all rights in this document and in the information contained therein. Reproduction use or disclosure to third parties without express authority is strictly forbidden.

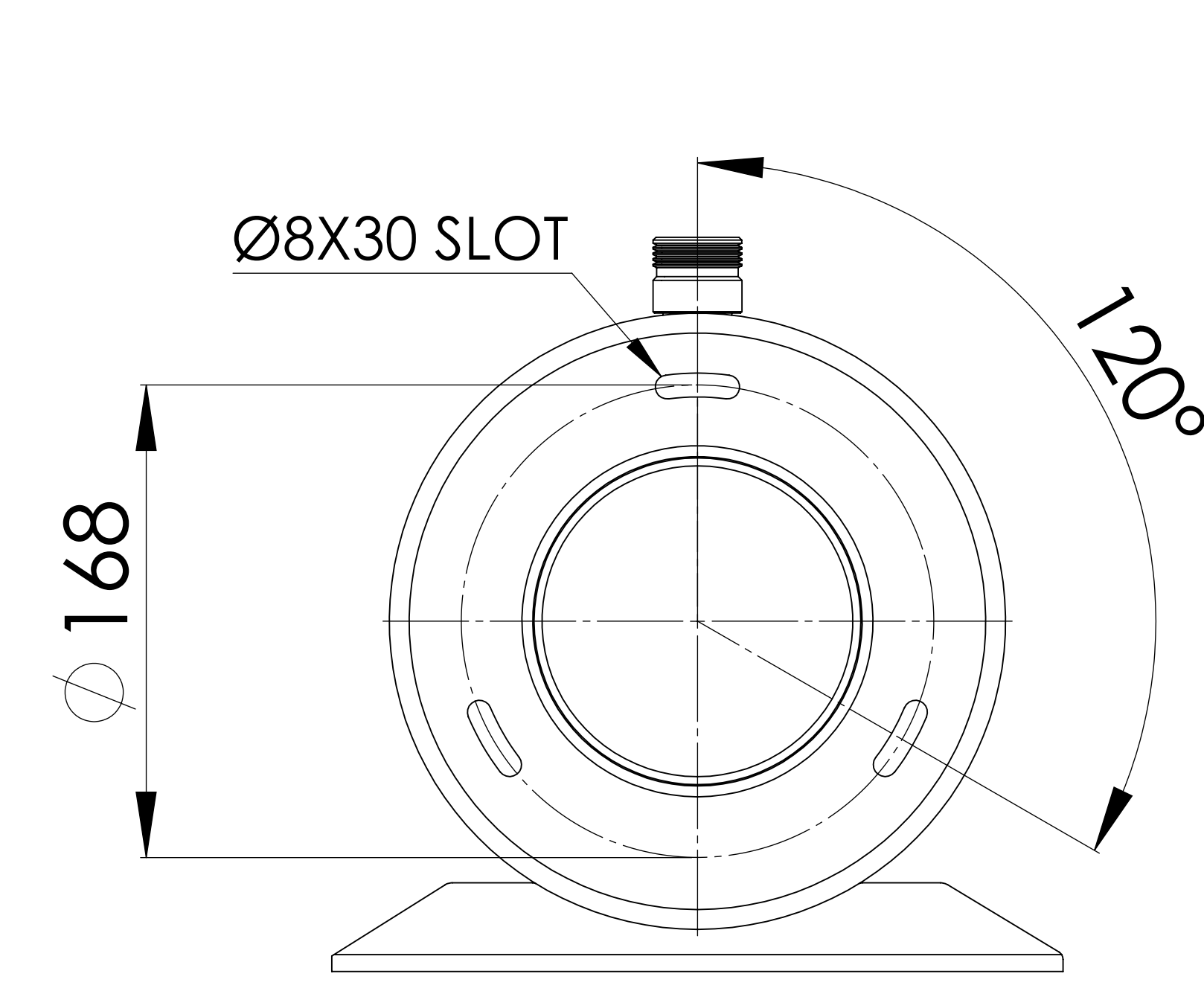
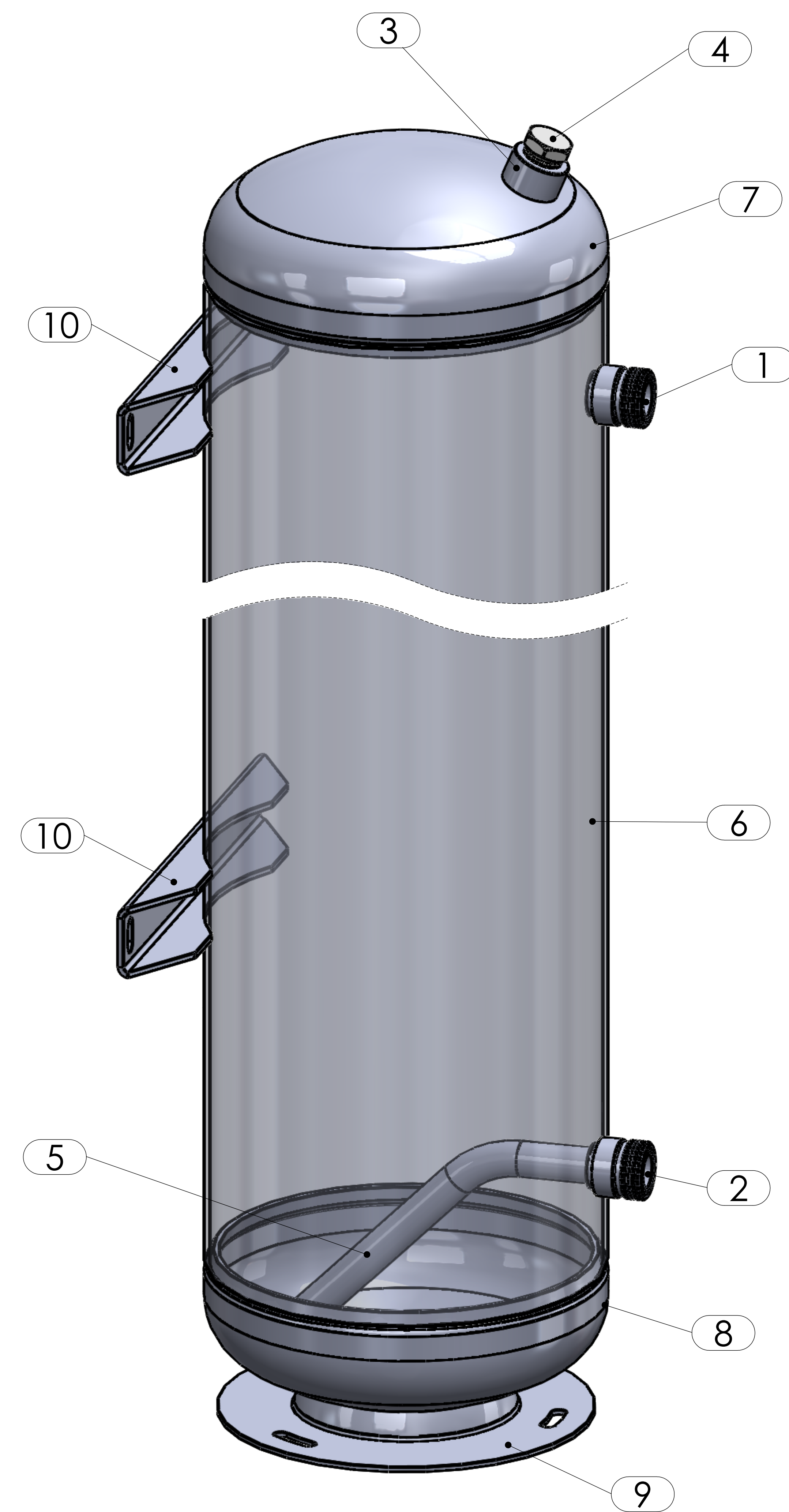
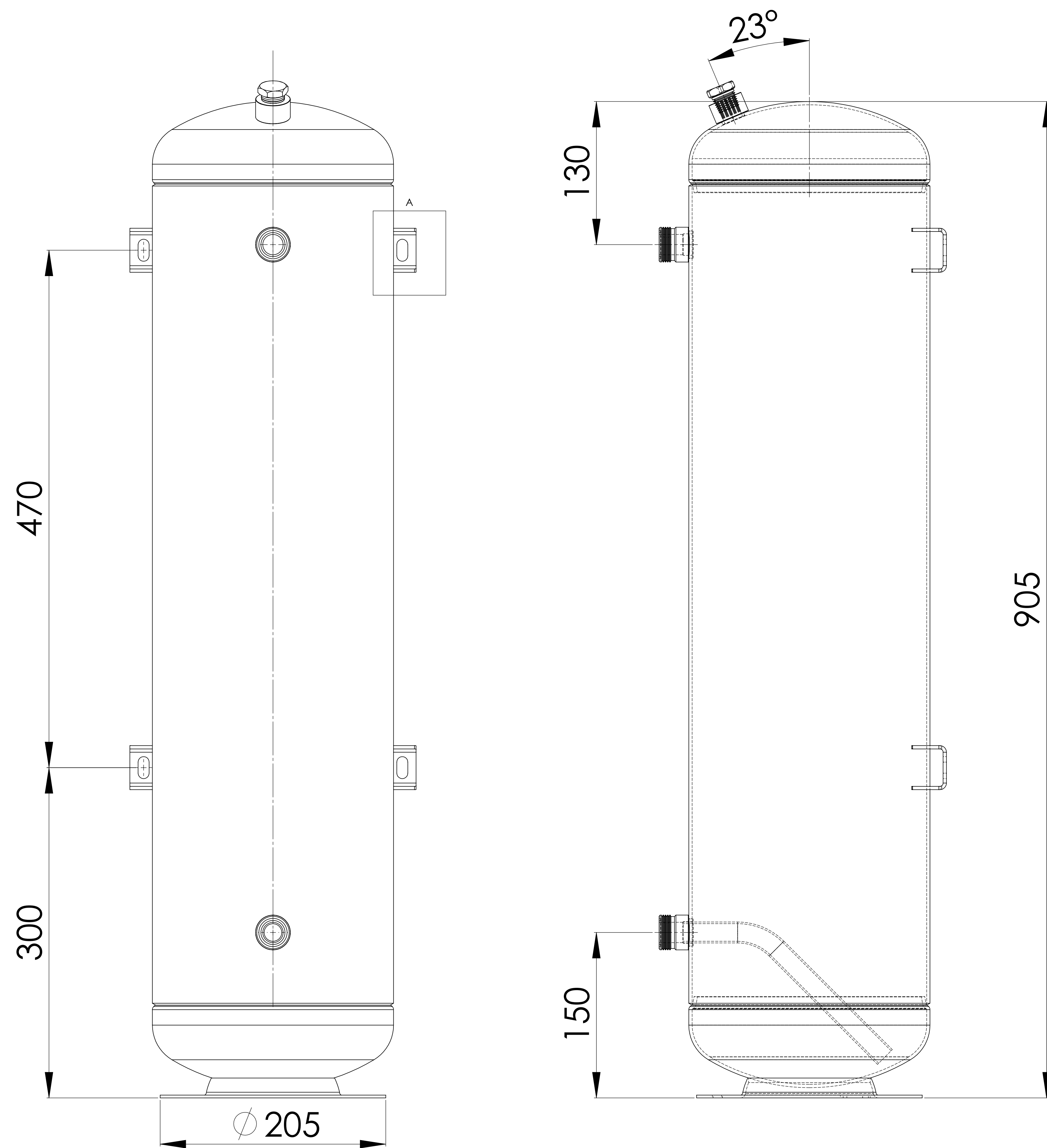

BOTTOM VIEW

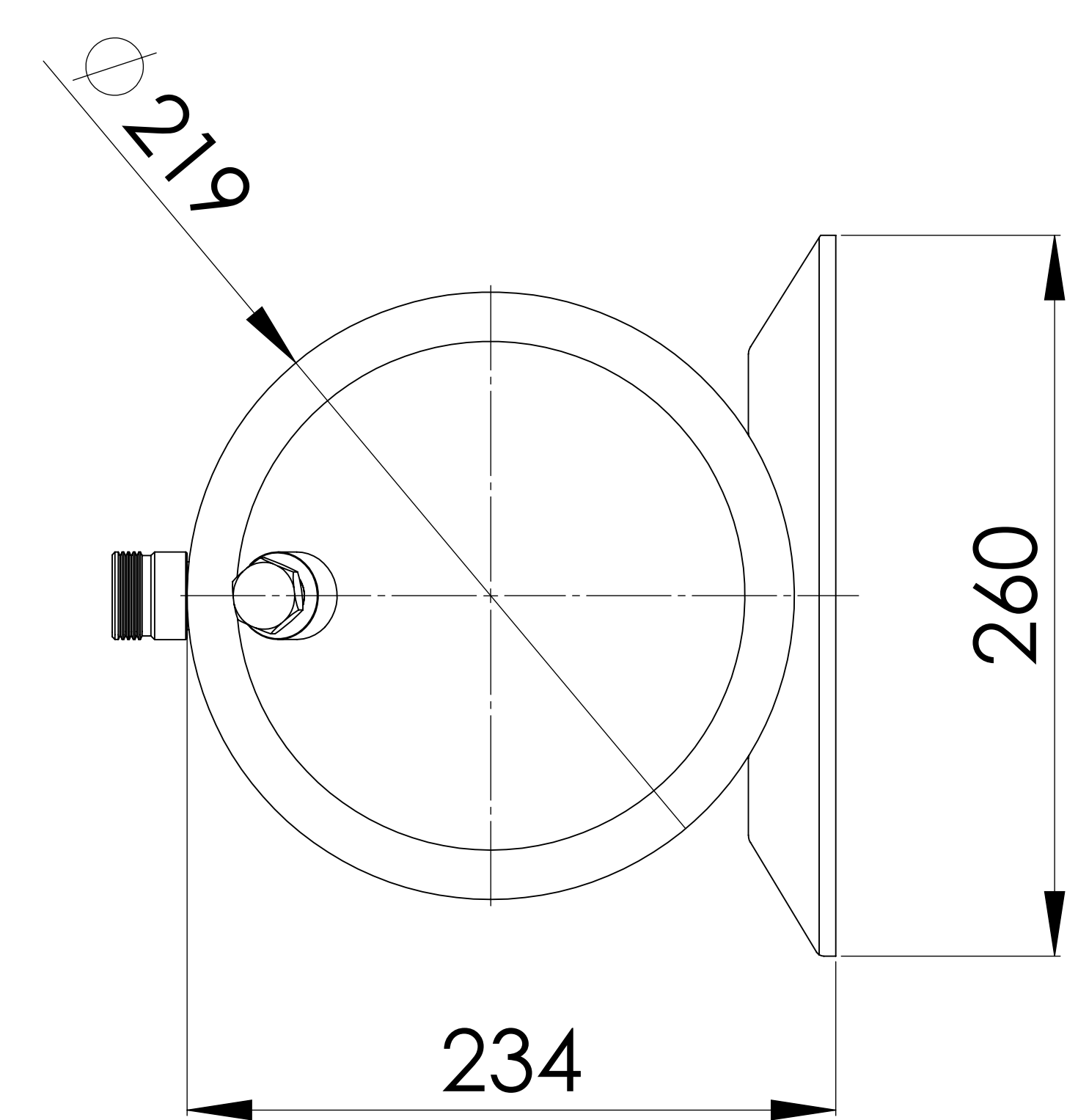

TOP VIEW

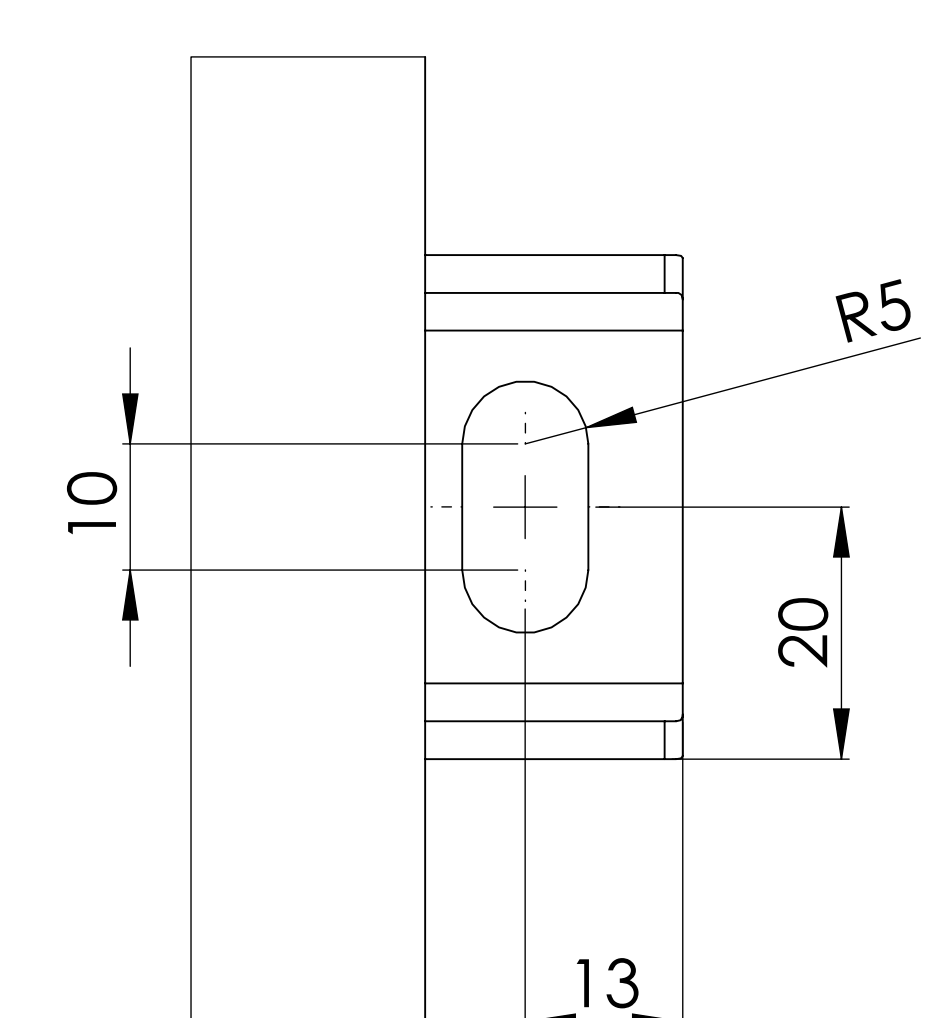

Detail: A
1 : 0.6

No	Assembly Codes	Qty
1	M002.000096	1