

GVN STANDART PRODUCT

Customer

UNIVERSAL LIQUID RECEIVERS

Product

HV9.33b.50.A4.A4.F4

Code

Customer Code

DESIGN DATA

Capacity [Lt.]	50 Lt.
Design Pressure [PS]	33 Bar
Pneumatic Test Pressure [PT]	36 Bar
Hydraulic Test Pressure	48 Bar
Design Temperature [TS]	Min.-20C / Max.+130C
Cooler Fluid Type	HFC-CFC-HCFC
Fluid Group	2
Category	CAT III / H
Desing Calculation	EN 14276-1/EN 13445-3
Welded Joint Efficiency	0.85
Material Group (Shell / Head)	1.2
Testing Group	3b
Corrasion Allowance	0,5 mm
Ndt	10%
Packaging Size & Weight	00*00*00 & 00 Kg.
Drawed By	Ö.TÜRKER
Approved By	D.GÜL
Date	27.04.2022
Color	RAL 5009

MATERIAL DATA

No	Connection	Model	Code	Material	Qty
1	Inlet Connection	ROT.1 3/4" H:32	106.060.A04.001.001	E 275	1
2	Outlet Connection	ROT.1 3/4" H:32	106.060.A04.001.001	E 275	1
3	Safety Valve Conn.	NPT 1/2" H:18	106.060.F04.000.001	E275-S144	1
4	Blind Plug	NPT 1/2" Plug	106.130.F04.001.001	E275	1
5	Pipe	RV MNS 1 3/4" Ø28,5x1,5	204.B28.015.324.240	E235	1
6	Shell	Ø323,9x4 H:504	204.HV9.33B.050.001	P355NH EN10217-3	1
7	Head Torispheric	Ø324x4 H:100	201.033.324.001.002	P355GH EN 10028-2	1
8	Head - Torispheric	Ø323,9x4 H:100	101.033.324.001.000	P355GH EN 10028-2	1
9	Skirt With	Ø320x2,5 H:27	105.004.320.001.001	EN 10111 DD-13	1
10	Foot	400x50x50,6 t:3	105.002.324.001.001	EN10111-DD13	2

GENERAL NOTES

- Max. allowable operating pressure (PS) according to the temperature range;
- 1) Allowable operating temperature : min. -20C° / max. +130C° PS1 = 33 Bar
- 2) Allowable operating temperature : min. -20C° / max. -40C° PS2 = 24 Bar
- Unless otherwise specified dimensions in MM
- Unless otherwise specified do not scale
- Unless otherwise specified tube must be clean&free form burrs inside&outside&uitable for soldering
- Unless otherwise specified do not scale indicated thickness are min. after forming or machining
- Unless otherwise specified dimension tolerances according to EN 113445-4

REVISIONS

No	Details Of Change	Date	By
01			
02			
03			

RELATED DRAWINGS

No	Description	Drawing No
01		
02		

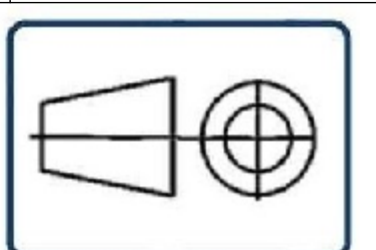

No	Assembly Codes	Qty
1	M002.000104	1

We reserve all rights in this document and in the information contained therein. Reproduction use or disclosure to third parties without express authority is strictly forbidden.

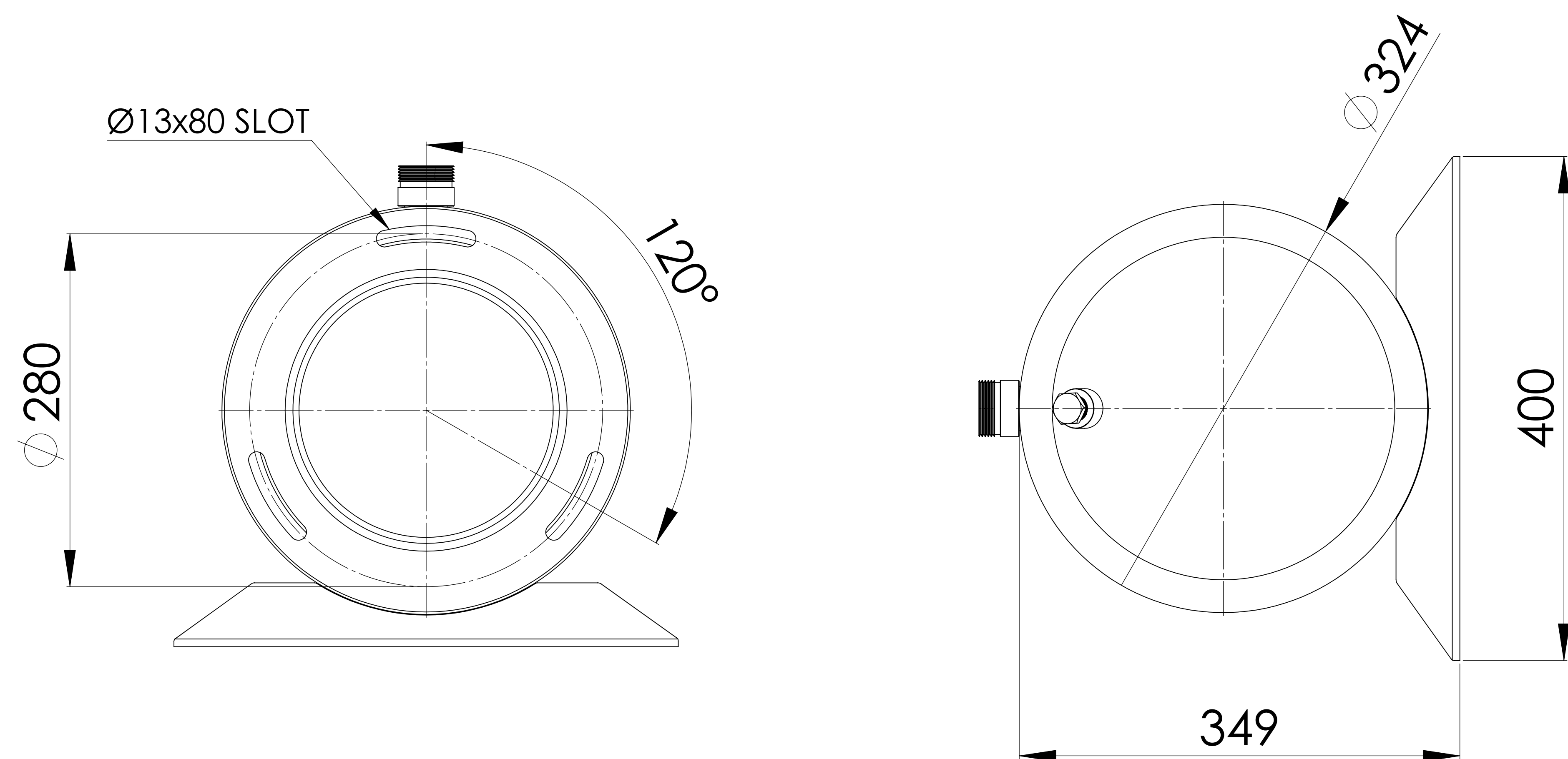
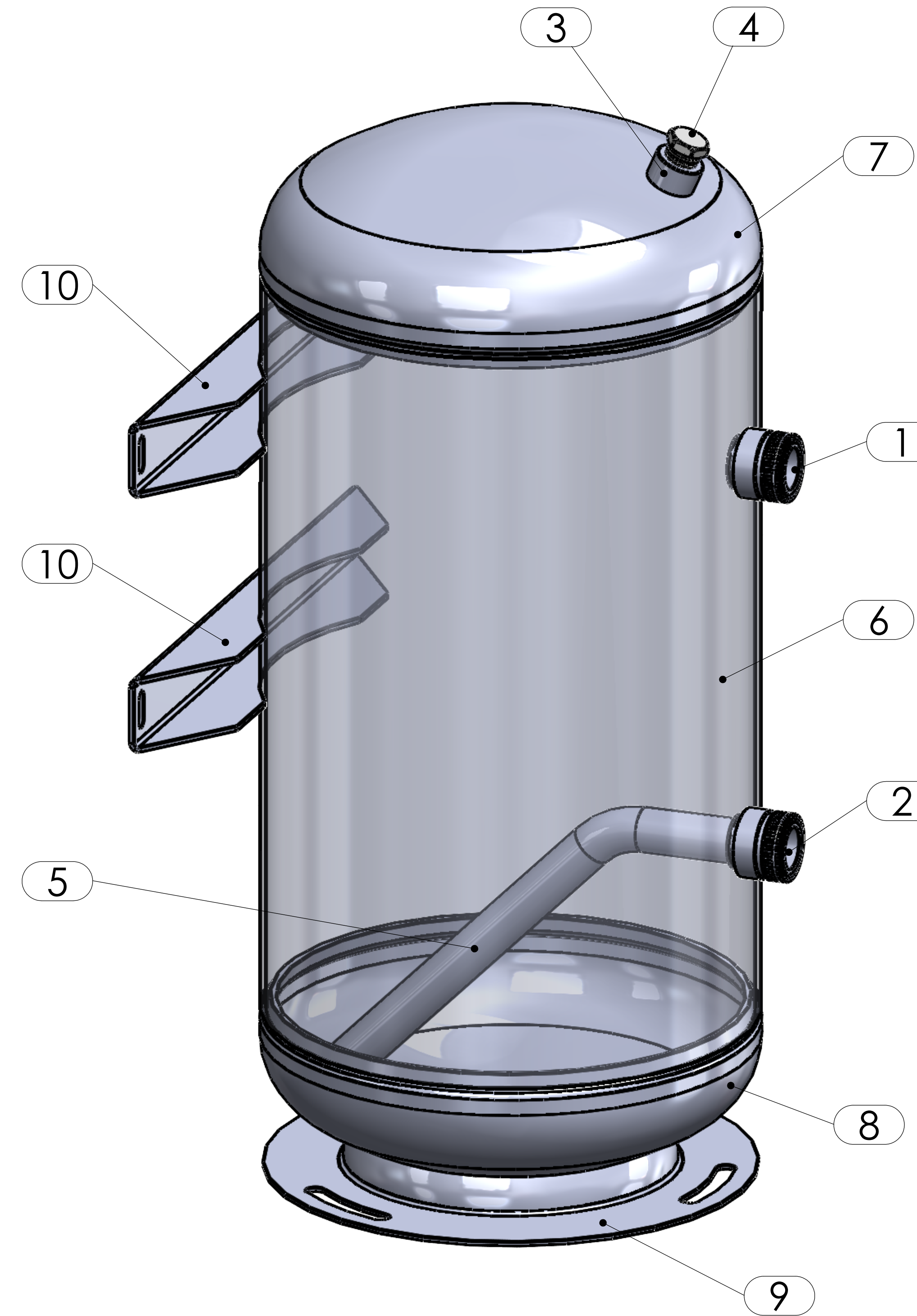
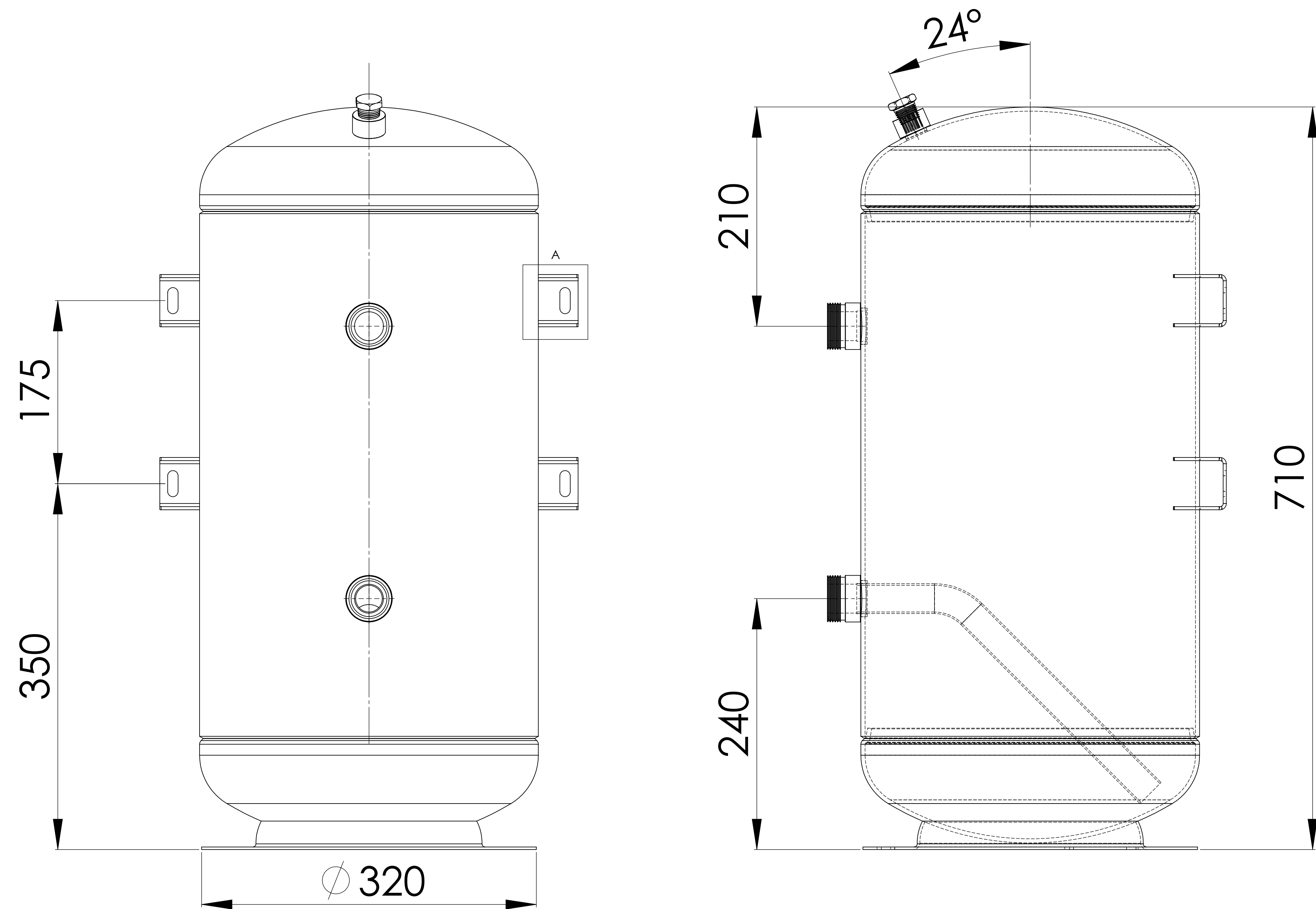

BOTTOM VIEW

TOP VIEW

Detail: A
2 : 1.5