

GÜVEN SOĞUTMA
ÜNİTELERİ SAN. VE TİC. A.Ş.

Add.: Hastane Mah. Hadimköy İstanbul Cd. No:78/1
34555, Arnavutköy, İstanbul, TURKEY
Tel: +90 212 771 51 12 - 771 51 13
Fax: +90 212 771 51 10
www.gvn.com.tr



GVN STANDARD PRODUCT

Customer

COALESCENT OIL SEPARATORS

Product

OS.C.130b.54.1

Code

Customer Code

DESIGN DATA

Pre-charge / Capacity [Lt.]	4,1/26,9
Design Pressure [PS]	130 Bar
Pneumatic Test Pressure [PT]	143 Bar
Hydraulic Test Pressure	186 Bar
Design Temperature [TS]	Min.-20C / Max.+130C
Cooler Fluid Type	HFC-CFC-HCFC-R744
Fluid Group	2
Category	CAT IV / H1
Desing Calculation	EN 14276-1/EN 13445-3
Welded Joint Efficiency	0.85
Material Group (Shell / Head)	1.2
Testing Group	3b
Corrasion Allowance	0,5 mm
Ndt	10%
Packaging Size & Weight	00*00*00 & 00 Kg.
Drawed By	M.ABDULAZİZ
Approved By	D.GÜL
Date	03.04.2023
Color	RAL 5009

MATERIAL DATA

No	Connection	Model	Code	Material	Qty
1	Inlet Connection	ODS 2 1/8" H:83,5	106.130.B10.000.003	ST44-E275	1
2	Extra Connection	ODS 2 1/8"	106.130.B10.000.001	E275	1
3	Outlet Connection	ODS 1/4" H:50	106.130.B01.000.002	S235JR	1
4	Pipe	Ø9x1	204.A09.010.000.200	EN10297-1 E235	1
5	Level Sensor Conn.	NPT 1/2"	106.130.F04.000.001	E275	1
6	Blind Plug	NPT 1/2"Plug	106.130.F04.001.001	E275	1
7	Elbow	60,3x2,9	114.060.001.001.001	S235JR	1
8	Holder Support	Ø92x49	105.010.FK0.145.003	S235	1
9	Filter Holder	Ø175x10	105.010.FK0.145.005	S235	1
10	Threaded Rod	M10x450	109.100.450.088.CO1	8.8	1
11	Filter	FK.165.1	FK.165.1		1
12	Plastic Washer	Ø55x2	109.100.000.000.P01		1
13	Metal Washer	Ø55x3	105.010.FK0.145.004	S235JR	1
14	Plastic Washer	M10	109.100.000.000.P02		1

GENERAL NOTES

- Max. allowable operating pressure [PS] according to the temperature range;
- 1) Allowable operating temperature : min. -20C° / max. +130C° PS1 = 130 Bar
- 2) Allowable operating temperature : min. -40C° / max. -20C° PS2 = 97,5 Bar
- Unless otherwise specified dimensions in MM
- Unless otherwise specified do not scale
- Unless otherwise specified tube must be clean&free from burrs inside&outside& suitable for soldering
- Unless otherwise specified do not scale indicated thickness are min. after forming or machining
- Unless otherwise specified dimension tolerances according to EN 113445-4

REVISIONS

No	Details Of Change	Date	By
01			
02			
03			

RELATED DRAWINGS

No	Description	Drawing No
01		
02		

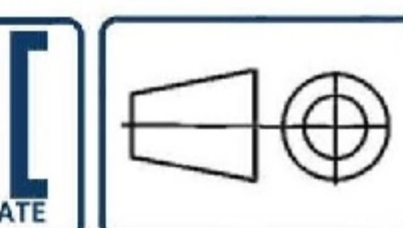

We reserve all rights in this document and in the information contained therein. Reproduction use or disclosure to third parties without express authority is strictly forbidden.

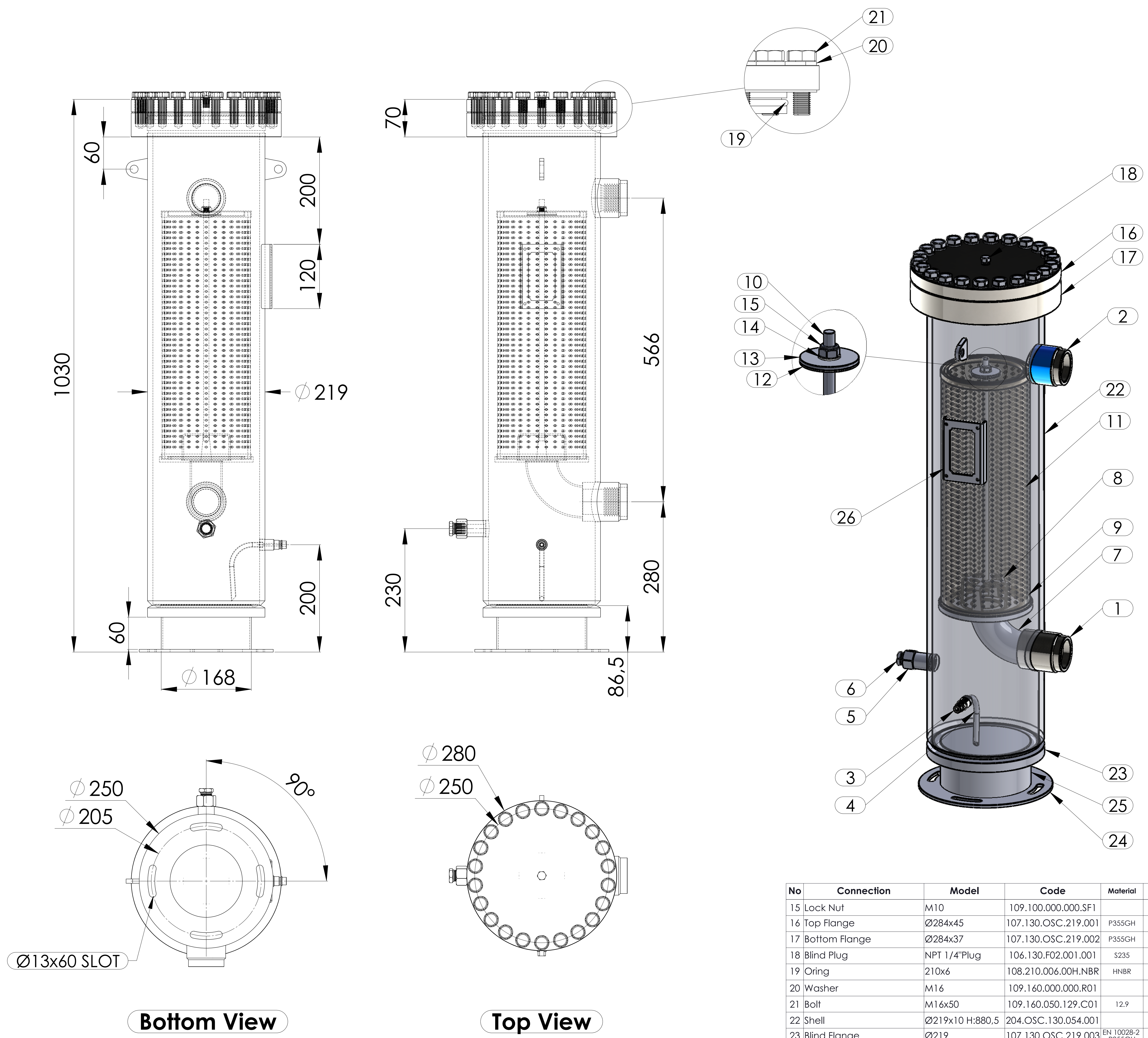

No	Connection	Model	Code	Material	Qty
15	Lock Nut	M10	109.100.000.000.SF1		1
16	Top Flange	Ø284x45	107.130.OSC.219.001	P355GH	1
17	Bottom Flange	Ø284x37	107.130.OSC.219.002	P355GH	1
18	Blind Plug	NPT 1/4"Plug	106.130.F02.001.001	S235	1
19	Oring	210x6	108.210.006.00H.NBR	HNBR	1
20	Washer	M16	109.160.000.000.R01		22
21	Bolt	M16x50	109.160.050.129.CO1	12.9	22
22	Shell	Ø219x10 H:880,5	204.OSC.130.054.001		1
23	Blind Flange	Ø219	107.130.OSC.219.003	EN 10028-2 P355GH	1
24	Base Plate	Ø250x5	105.005.250.001.001	S235	1
25	Pipe	Ø168x60	104.130.H60.250.168	S235	1
26	Label Plate	120x80x2	105.006.002.120.080	DD-13	1

No	Assembly Codes	Qty
1	M005.000434	1