

GVN STANDART PRODUCT

Customer

COALESCENT OIL SEPARATORS & RESERVOIR

Product

OS.CR.45b.28.1

Code

Customer Code

**DESIGN DATA**

Pre-charge / Capacity [Lt.]	3,0 / 5,6
Design Pressure [PS]	45 Bar
Pneumatic Test Pressure [PT]	50 Bar
Hydraulic Test Pressure	65 Bar
Design Temperature [TS]	Min.-20C / Max.+130C
Cooler Fluid Type	HFC-CFC-HCFC-R744
Fluid Group	2
Category	CAT II / D1
Desing Calculation	EN 14276-1/EN 13445-3
Welded Joint Efficiency	0.85
Material Group (Shell / Head)	1.2
Testing Group	3b
Corrasion Allowance	0,5 mm
Ndt	10%
Packaging Size & Weight	00*00*00 & 00 Kg.
Drawed By	M.ABDULAZİZ
Approved By	D.GÜL
Date	18.05.2023
Color	RAL 5009

**MATERIAL DATA**

No	Connection	Model	Code	Material	Qty
1	Inlet Connection	ODS 1 1/8" H:53	106.060.B07.000.007	E275	1
2	Outlet Connection	ODS 1 1/8" H:40	106.060.B07.000.002	E275	1
3	Oil Return Connection	ROT. 1" H:25	106.060.A02.001.001	E275-ST44	1
4	Outlet Valve	RV.45b-3/8S			1
5	Pipe	Ø13x1	204.A13.010.000.120	EN10297-1 E235	1
6	Sight Glass Type Conn.	SG-SW38 H:27	106.05W.038.001.001	E275	2
7	Sight Glass	SW38	SW-38	E275-ST44	2
8	Elbow	33.7x2.6	114.033.001.001.001	S235JR	1
9	Holder Support	Ø46x30	105.010.FK0.065.003	S235	1
10	Filtre Holder	Ø80x5	105.010.FK0.065.001	S235	1
11	Threaded Rod	M8 x 250mm	109.080.250.088.CO1	8.8	1
12	Filter	FK.65.1	FK.65.1		1
13	Plastic Washer	M8	109.080.000.000.P03		1
14	Metal Washer	M8	109.080.000.000.P02		1

**GENERAL NOTES**

- Max. allowable operating pressure (PS) according to the temperature range:
- 1) Allowable operating temperature : min. -20C° / max. +130C° PS1 = 45 Bar
- 2) Allowable operating temperature : min. -40C° / max. -20C° PS2 = 33 Bar
- Unless otherwise specified dimensions in MM
- Unless otherwise specified do not scale
- Unless otherwise specified tube must be clean&free from burrs inside&outside&uitable for soldering
- Unless otherwise specified do not scale indicated thickness are min. after forming or machining
- Unless otherwise specified dimension tolerances according to EN 113445-4

**REVISIONS**

No	Details Of Change	Date	By
01			
02			
03			

**RELATED DRAWINGS**

No	Description	Drawing No
01		
02		



We reserve all rights in this document and in the information contained therein. Reproduction use or disclosure to third parties without express authority is strictly forbidden.

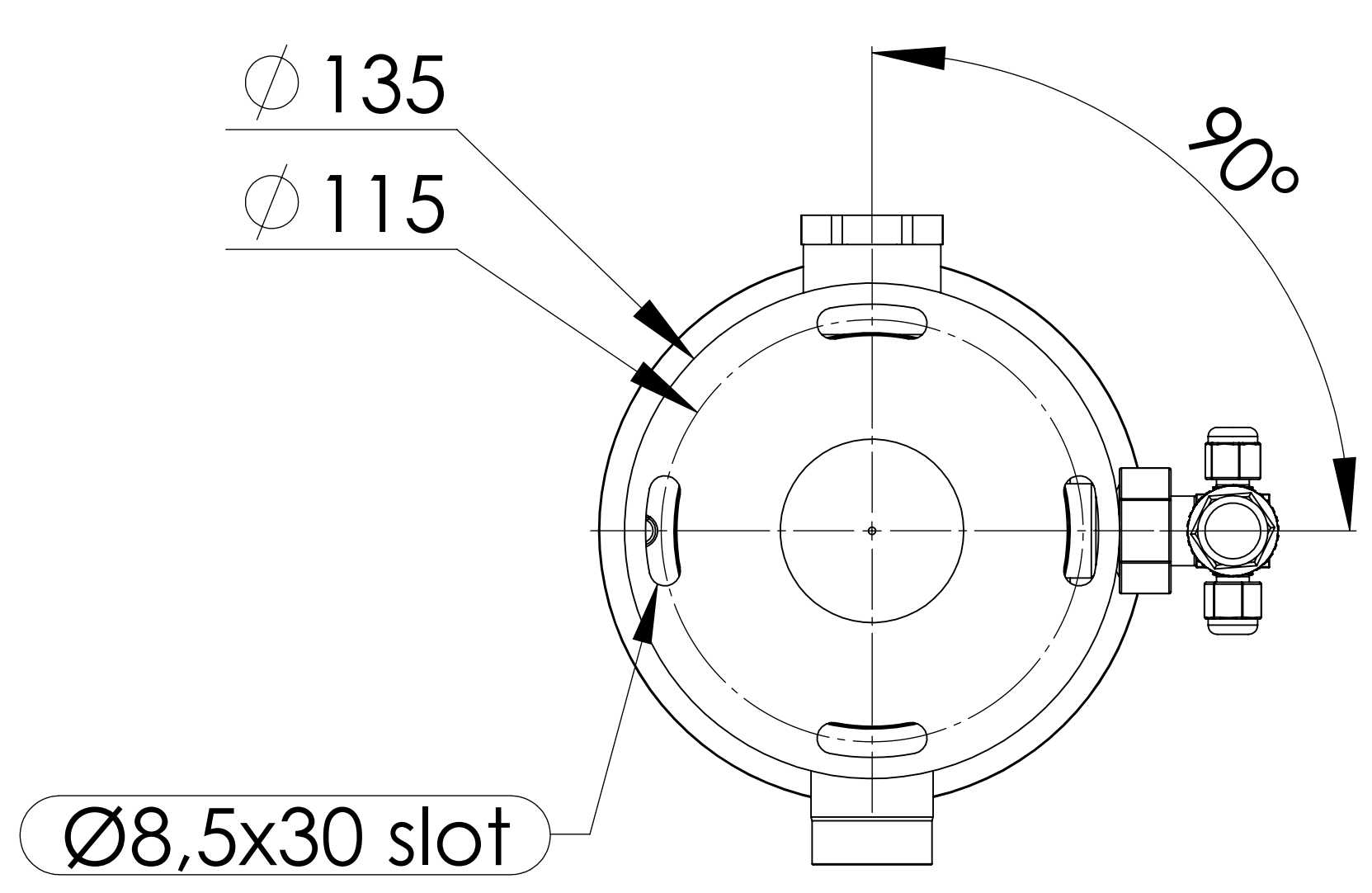
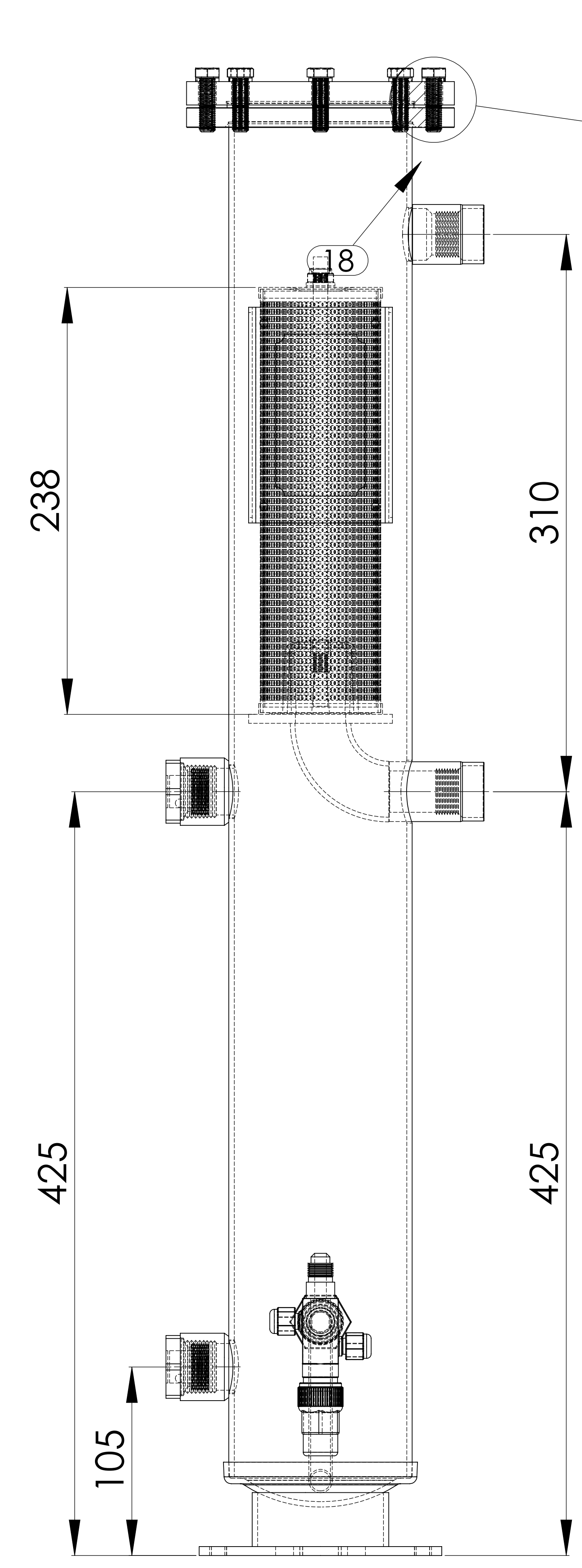
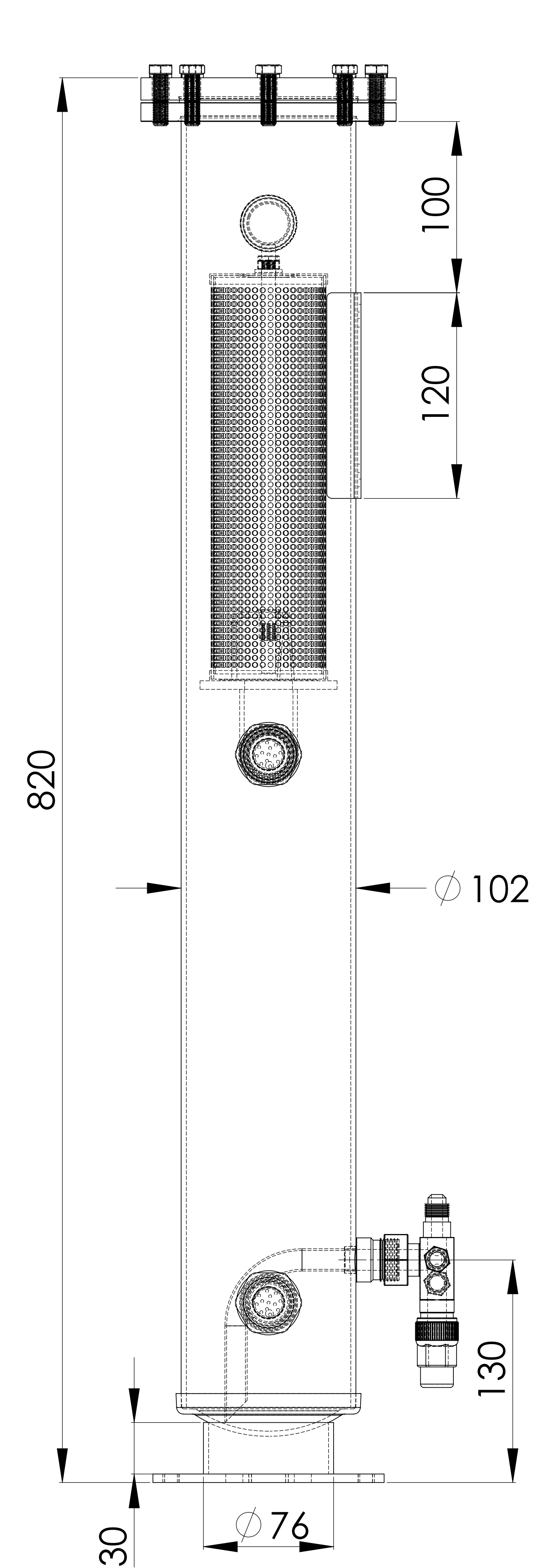
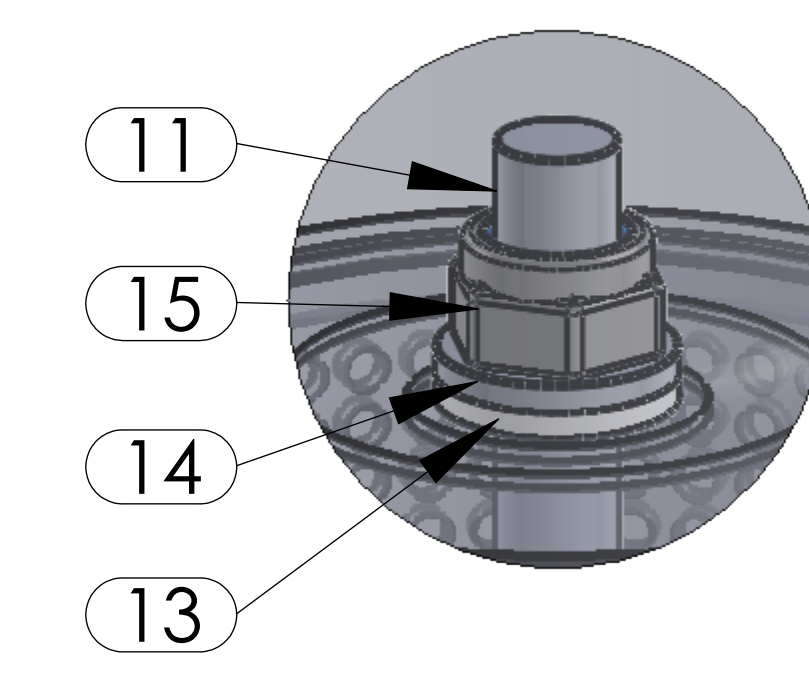
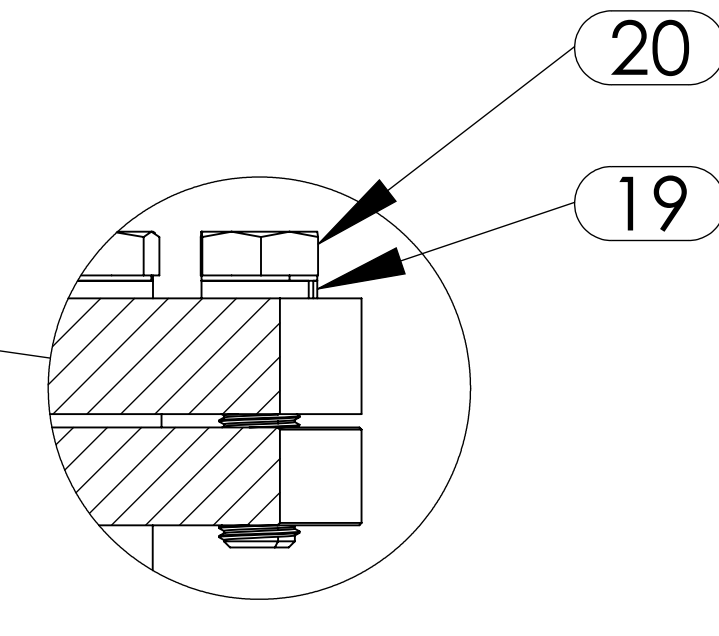
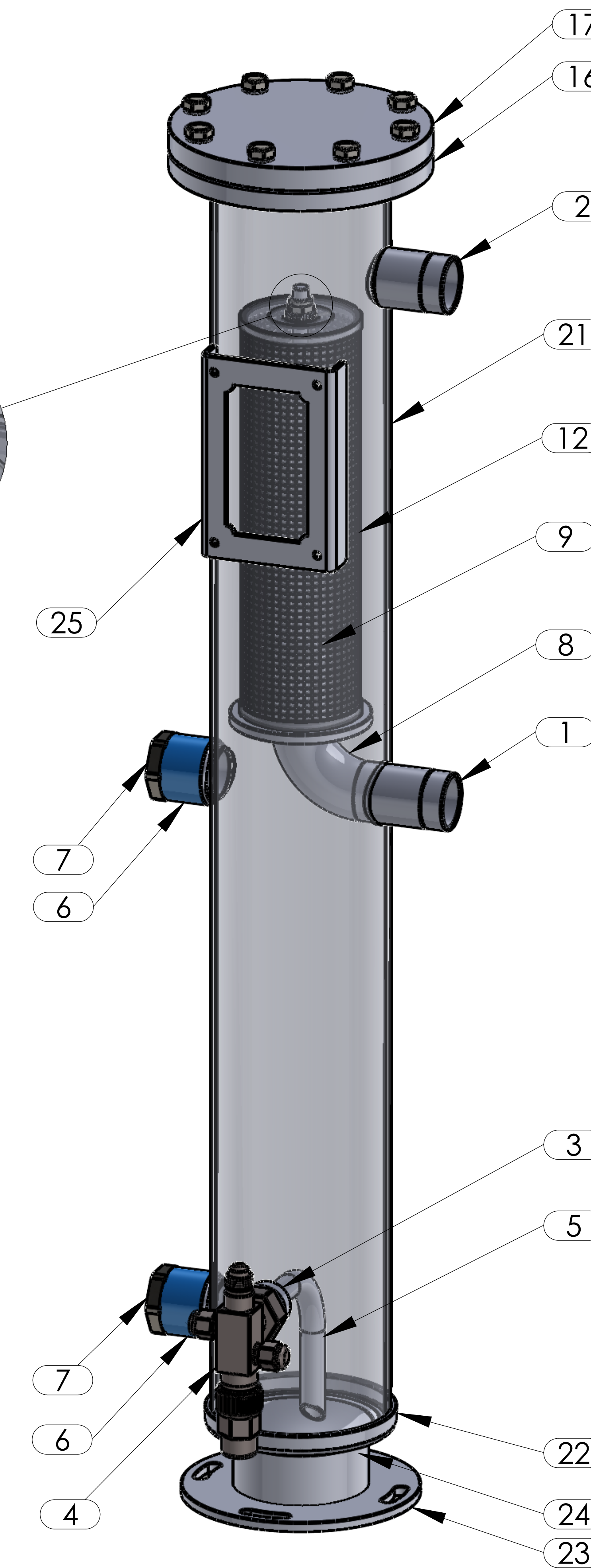

**Bottom View**

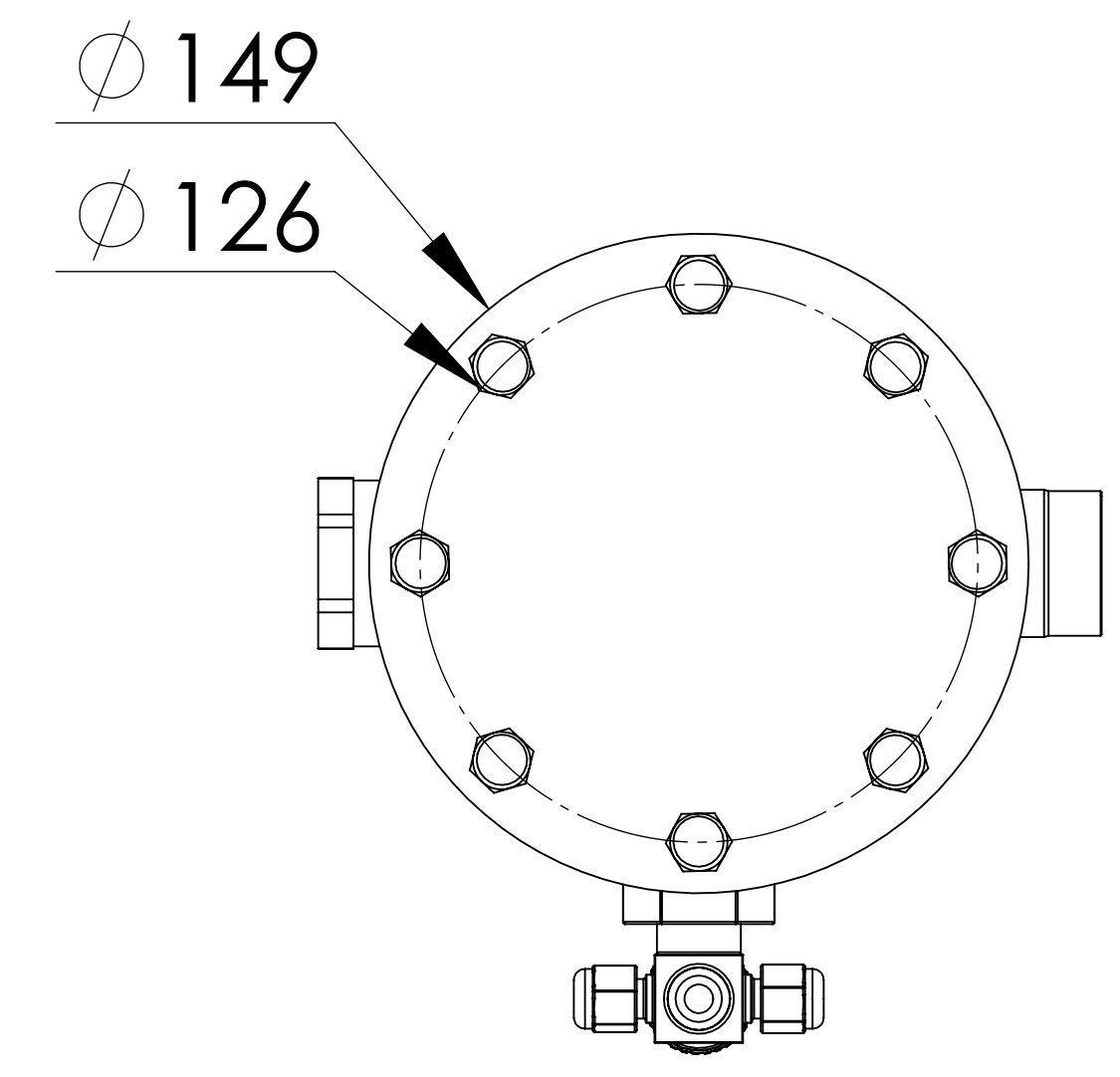

**Top View**

No	Assembly Codes	Qty
1	M005.000437	1

No	Connection	Model	Code	Material	Qty
15	Lock Nut	M8	109.080.000.000.SF1		1
16	Bottom Flange	Ø149x95x13,5	107.045.OSC.102.004	P355GH+N	1
17	Top Flange	Ø149x13	107.045.OSC.102.003	P355GH+N	1
18	Gasket	KLINGERIT	108.104.095.000.K01	GP-150	1
19	Washer	M8	109.080.000.000.R01		8
20	Bolt	M8x30	109.080.030.088.C01	8.8	8
21	Shell	Ø102x3 H:753,5	204.OSC.R60.028.001	P355NH-EN10217-3	1
22	Cover	Ø102x3	101.045.102.001.000	P355GH-EN10028-2	1
23	Base Plate	Ø135 t:5	105.005.135.001.001	S235	1
24	Skirt	Ø76x3 H:30	104.045.H30.135.076	S235	1
25	Label Plate	120x80x2	105.006.002.120.080	DD-13	1