

GÜVEN SOĞUTMA
ÜNİTELERİ SAN. VE TİC. A.Ş.

Addr.: Hastane Mah. Hadimköy İstanbul Cd. No:78/1
 34555, Arnavutköy, İstanbul, TÜRKİYE
 Tel: +90 212 771 51 12 - 771 51 13
 Fax: +90 212 771 51 10
 www.gvn.com.tr



GVN STANDARD PRODUCT	Customer
HELICAL OIL SEPARATORS	Product
OS.H.45b.42.1	Code
	Customer Code

DESIGN DATA	
Pre-charge / Capacity [Lt.]	1,46 / 6,1
Design Pressure [PS]	45 Bar
Pneumatic Test Pressure [PT]	50 Bar
Hydraulic Test Pressure	65 Bar
Design Temperature [TS]	Min.-20C / Max.+130C
Cooler Fluid Type	HFC-CFC-HCFC
Fluid Group	2
Category	CAT II / D1
Desing Calculation	EN 14276-1/EN 13445-3
Welded Joint Efficiency	0.85
Material Group (Shell / Head)	1.2
Testing Group	3b
Corrasion Allowance	0,5 mm
Ndt	10%
Packaging Size & Weight	00*00*00 & 00 Kg.
Drawed By	M.ABDULAZİZ
Approved By	D.GÜL
Date	13.09.2022
Color	RAL 5009

MATERIAL DATA						
No	Connection	Model	Code	Material	Qty	
1	Inlet Connection	ODS 1 5/8" H:40	106.060.B09.000.001	E275	1	
2	Outlet Connection	ODS 1 5/8" H:40	106.060.B09.000.002	E275	1	
3	Oil Return Connection	SAE 3/8"	106.060.Y02.001.005	S235	1	
4	Head - Torispheric	Ø140x3 H:45	101.060.140.001.000	EN10028-2 P355GH	1	
5	Shell	Ø140x3 H:371	204.OSH.060.042.001	EN 10217-3 P355NH	1	
6	Head - Torispheric	Ø140x3 H:45	201.060.140.001.006	EN10028-2 P355GH	1	
7	Skirt With	Ø136X2,5 H:17	105.004.136.001.001	S235JR	1	

GENERAL NOTES

- Max. allowable operating pressure (PS) according to the temperature range:
- 1) Allowable operating temperature : min. -20C° / max. +130C° PS1 = 45 Bar
- 2) Allowable operating temperature : min. -20C° / max. -40C° PS2 = 33 Bar
- Unless otherwise specified dimensions in MM
- Unless otherwise specified do not scale
- Unless otherwise specified tube must be clean&free form burrs inside&outside&uitable for soldering
- Unless otherwise specified do not scale indicated thickness are min. after forming or machining
- Unless otherwise specified dimension tolerances according to EN 113445-4

REVISIONS			
No	Details Of Change	Date	By
01			
02			
03			

RELATED DRAWINGS		
No	Description	Drawing No
01		
02		



We reserve all rights in this document and in the information contained therein. Reproduction use or disclosure to third parties without express authority is strictly forbidden.

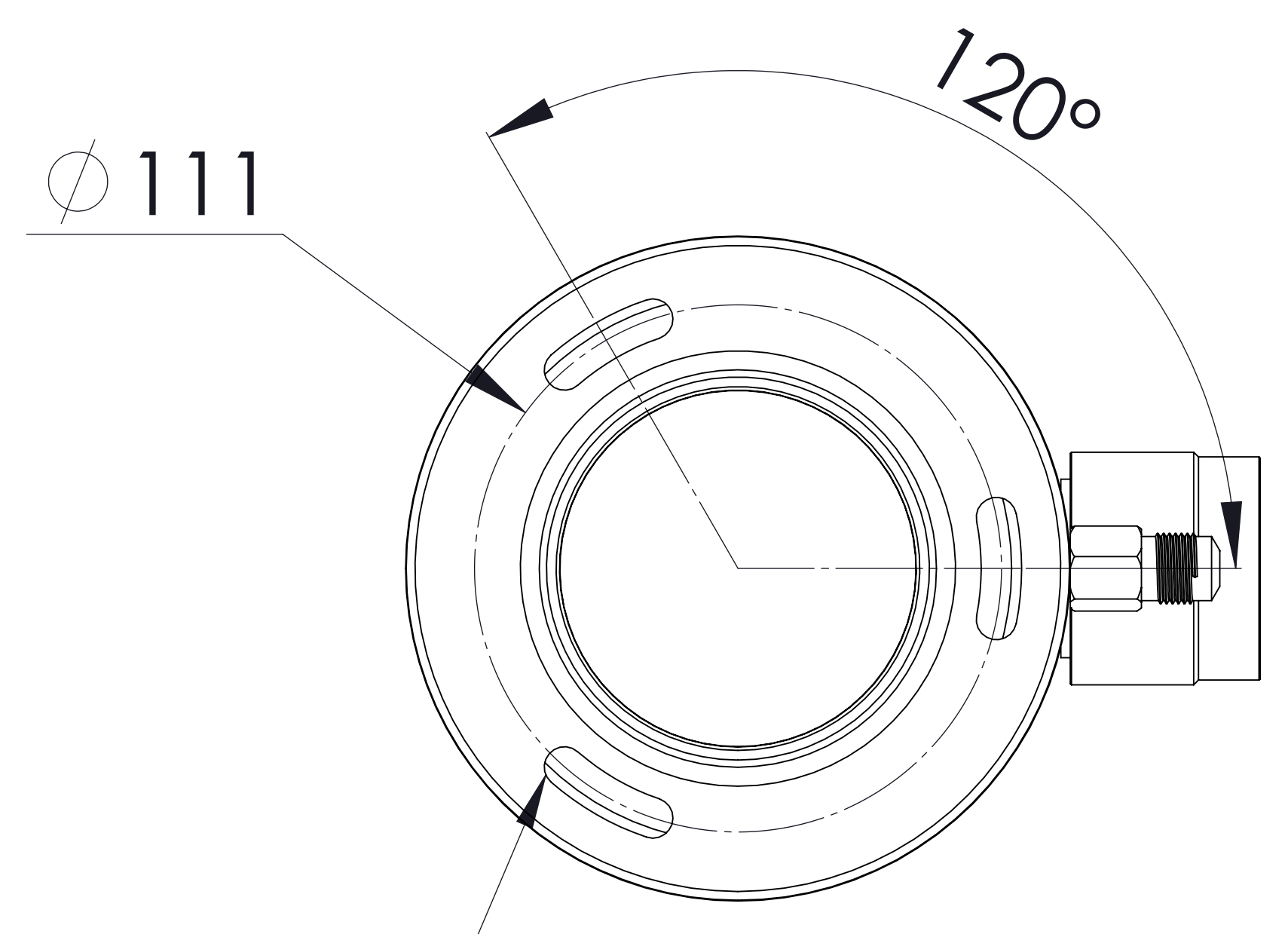
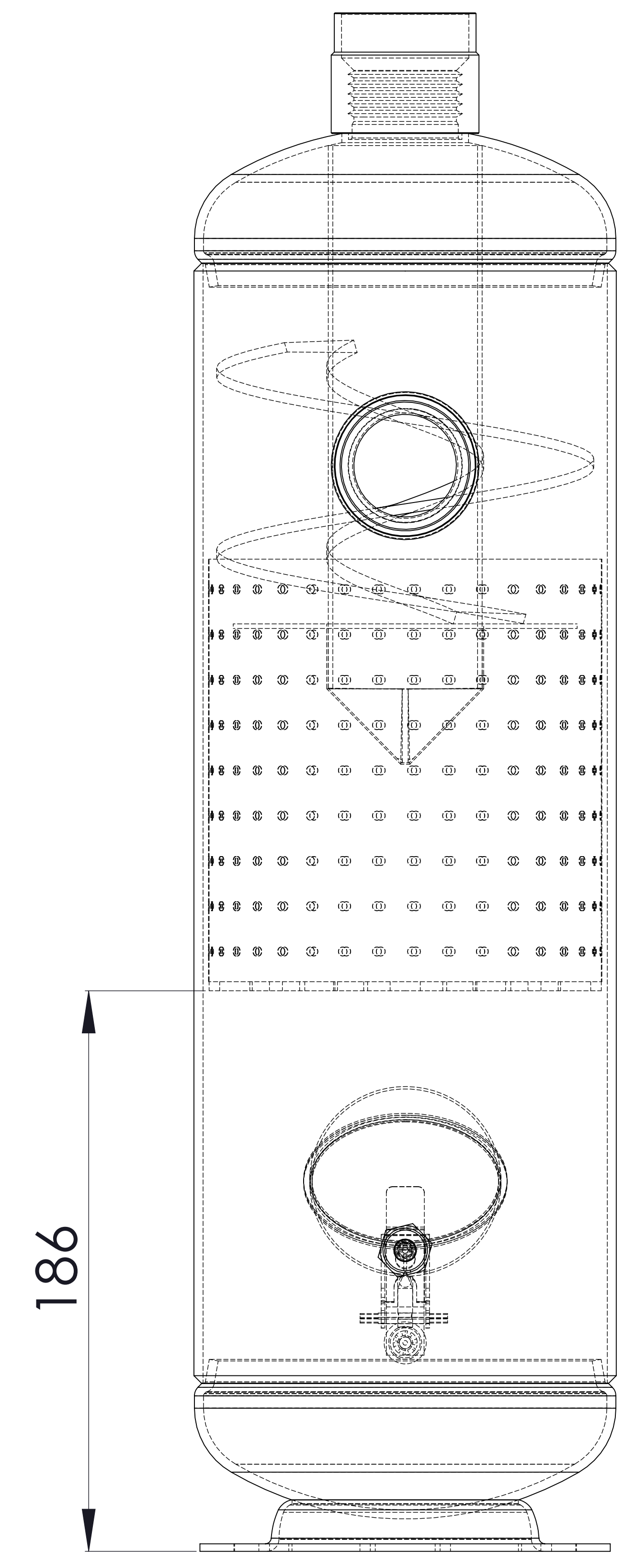
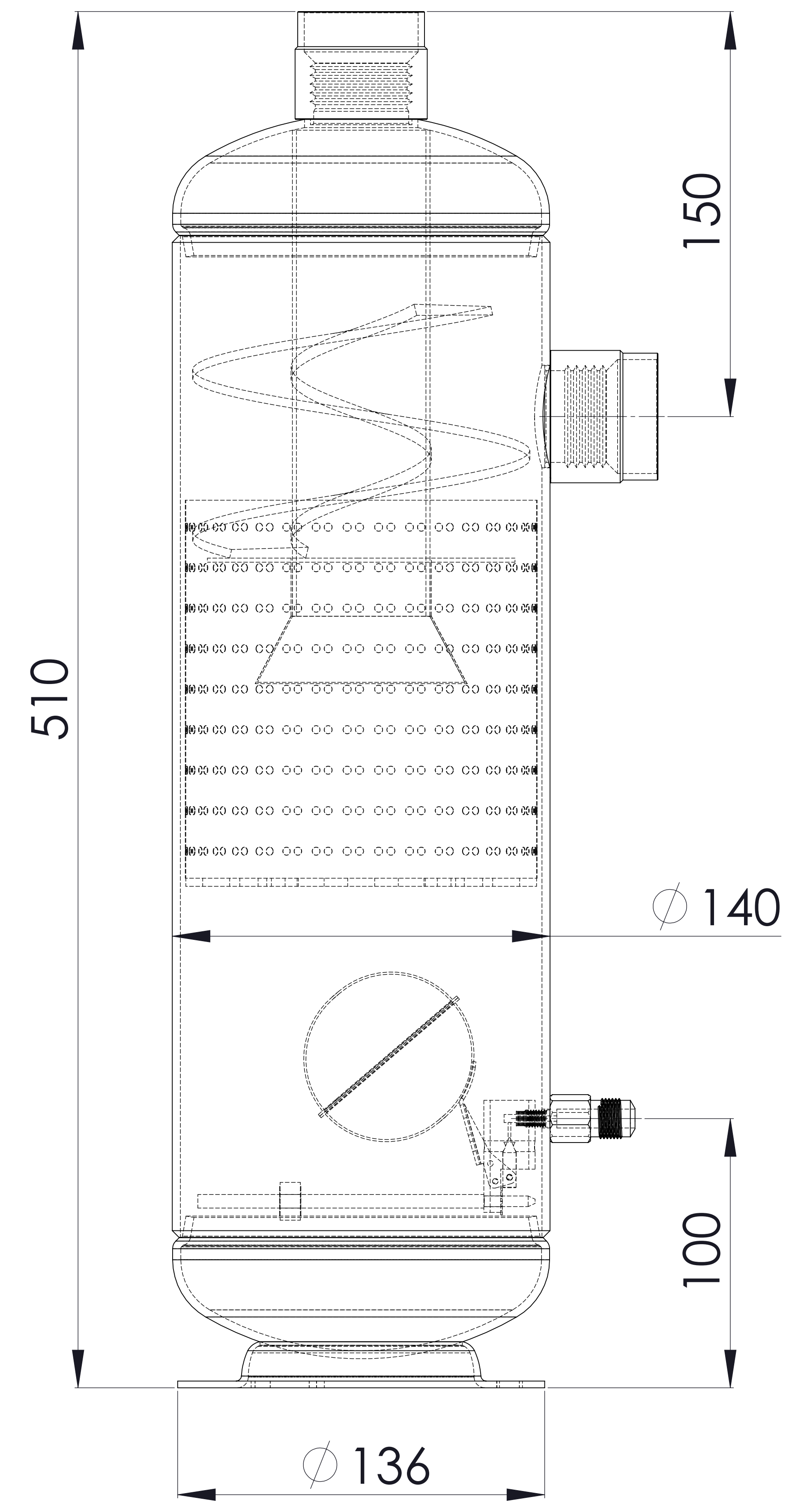

Bottom View

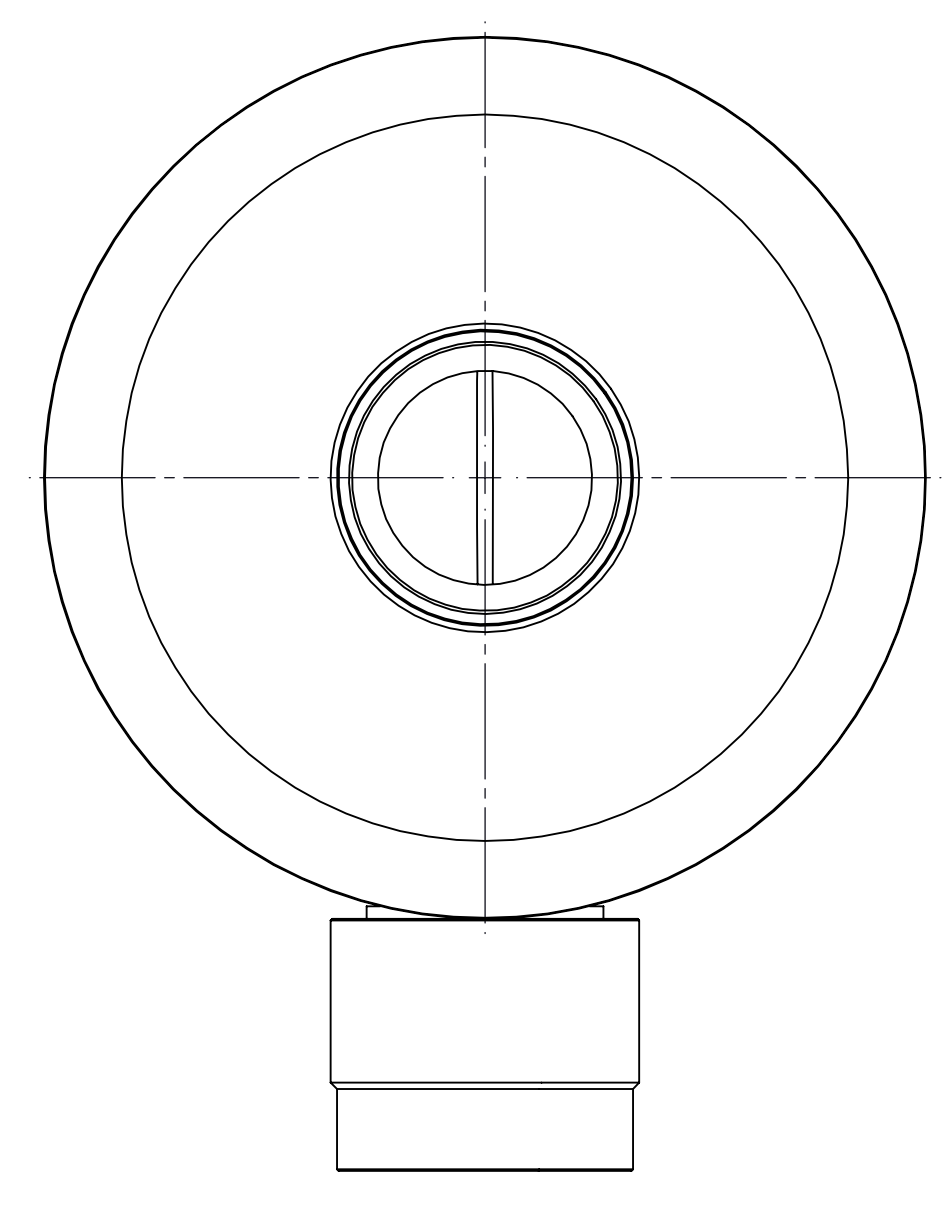

Top View

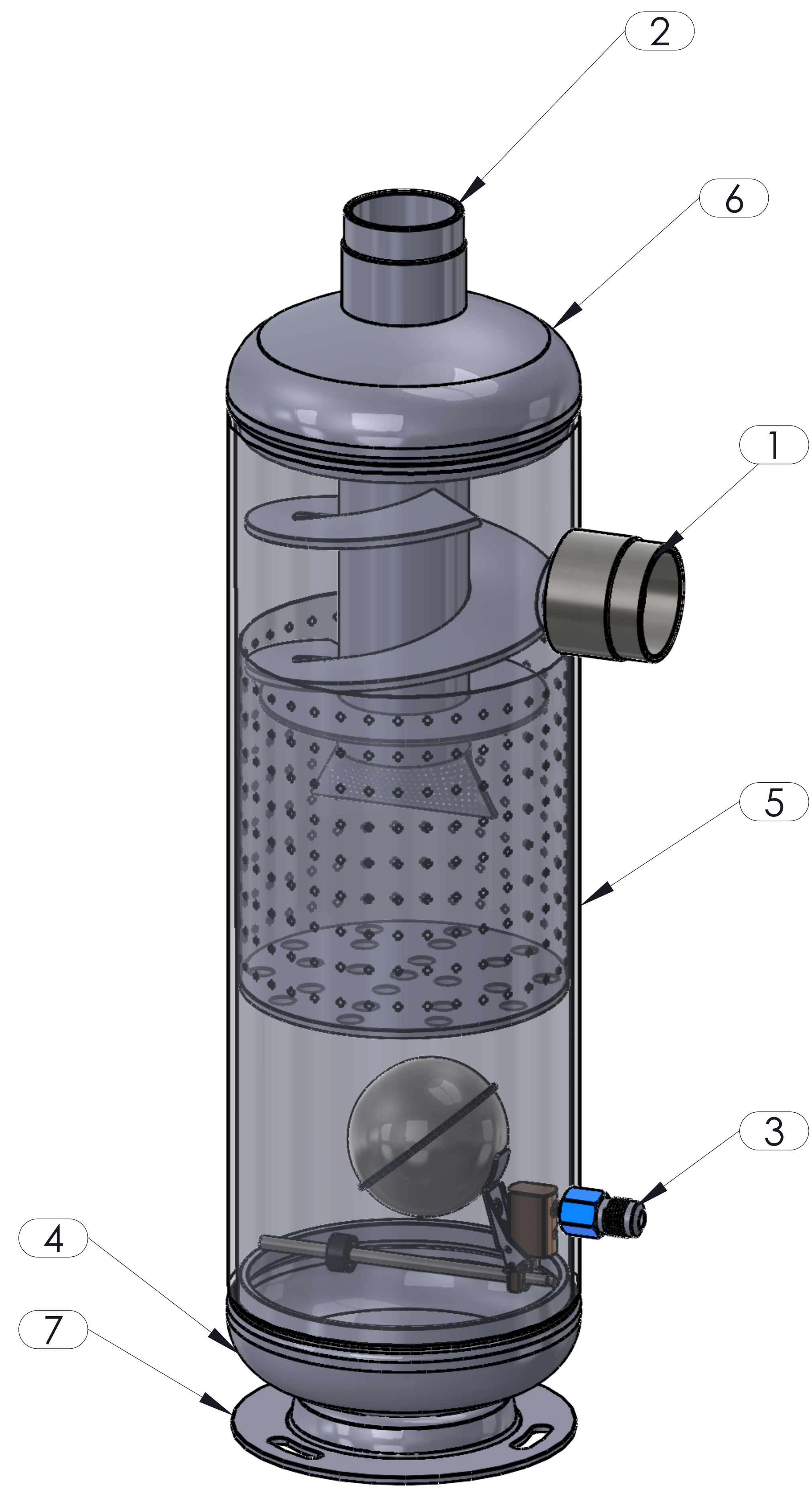

No	Assembly Code	Qty
1	M005.000321	1