

GÜVEN SOĞUTMA
ÜNİTELERİ SAN. VE TİC. A.Ş.
 Add.: Hastane Mah. Hadimköy İstanbul Cd. No:78/1
 34555, Arnavutköy, İstanbul, TÜRKİY
 Tel: +90 212 771 51 12 - 771 51 13
 Fax: +90 212 771 51 10
 www.gvn.com.tr



GVN STANDART PRODUCT	Customer
SUCTION LINE ACCUMULATORS	Product
SLA.A.45B.35.6.F4	Code
	Customer Code

DESIGN DATA	
Capacity [Lt.]	6 Lt.
Design Pressure [PS]	45 Bar
Pneumatic Test Pressure [PT]	50 Bar
Hydraulic Test Pressure	65 Bar
Design Temperature [TS]	Min.-20C / Max.+130C
Cooler Fluid Type	HFC-CFC-HCFC-R744
Fluid Group	2
Category	CAT II / D1
Desing Calculation	EN 14276-1/EN 13445-3
Welded Joint Efficiency	0.85
Material Group (Shell / Head)	1.2
Testing Group	3b
Corrasion Allowance	0,5 mm
Ndt	10%
Packaging Size & Weight	00*00*00 & 00 Kg.
Drawed By	Ö.TÜRKER
Approved By	D.GÜL
Date	19.12.2022
Color	RAL 5009

MATERIAL DATA					
No	Connection	Model	Code	Material	Qty
1	Inlet Connection	ODS 1 3/8" H:40	106.060.B08.000.001	E275	1
2	Outlet Connection	ODS 1 3/8" H:40	106.060.B08.000.002	E275	1
3	Safety Valve Conn.	NPT 1/2" H:18	106.060.F04.000.001	E275-ST44	1
4	Blind Plug	NPT 1/2" Plug	106.130.F04.001.001	E275	1
5	Pipe	Ø35x1,5	204.035.015.SLA.000	E235	1
6	Pipe	Ø60x1,5	204.060.015.SLA.000	E235	1
7	Shell	Ø140x3 H:346	204.SLA.060.140.003	P355NH EN 10217-3	1
8	Head - Torispheric	Ø140x3 H:45	101.060.140.001.000	EN10028-2 P355GH	1
9	Head - Torispheric	Ø140x3 H:45	201.060.140.001.006	EN10028-2 P355GH	1
10	Head Torispheric	Ø66,5x3 H:26	202.033.060.001.000	P355GH EN 10028-2	1
11	Skirt With	Ø136x2,5 H:17	105.004.136.001.001	S235JR	1

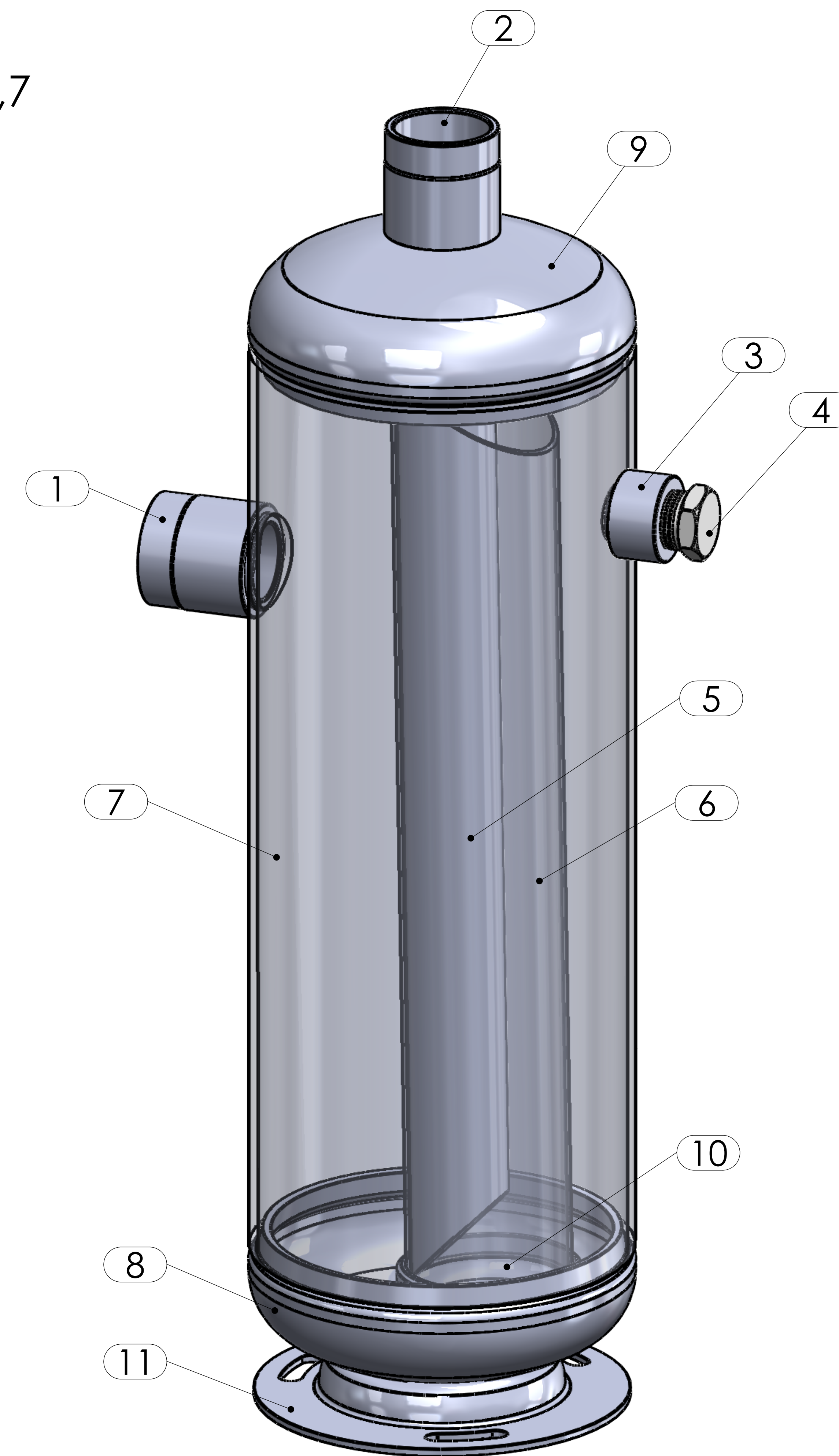

GENERAL NOTES

- Max. allowable operating pressure (PS) according to the temperature range:
- 1) Allowable operating temperature : min. -20C° / max. +130C° PS1 = 45 Bar
- 2) Allowable operating temperature : min. -40C° / max. -20C° PS2 = 33 Bar
- Unless otherwise specified do not scale
- Unless otherwise specified tube must be clean&free from burrs inside&outside&suitable for soldering
- Unless otherwise specified do not scale indicated thickness are min. after forming or machining
- Unless otherwise specified dimension tolerances according to EN 113445-4

REVISIONS			
No	Details Of Change	Date	By
01			
02			
03			

RELATED DRAWINGS		
No	Description	Drawing No
01		
02		

No	Assembly Codes	Qty
1	M005.000409	1



We reserve all rights in this document and in the information contained therein. Reproduction use or disclosure to third parties without express authority is strictly forbidden.