

STANDARD PRODUCTION	Customer
VERTICAL LIQUID RECEIVERS	Product
V10A.60B.100.B7.B7.B7.F4.H32	Code
	Customer Code

DESIGN DATA	
Capacity [Lt.]	100 Lt.
Design Pressure [PS]	60 Bar
Pneumatic Test Pressure [PT]	66 Bar
Hydraulic Test Pressure	86 Bar
Design Temperature [TS]	Min.-20C / Max.+130C
Cooler Fluid Type	HFC-CFC-HCFC-CO2
Fluid Group	2
Category	CAT IV / HI
Desing Calculation	EN 14276-1/EN 13445-3
Welded Joint Efficiency	0.85
Material Group (Shell / Head)	1.2
Testing Group	3b
Corrasion Allowance	0,5 mm
Ndt	10%
Packaging Size & Weight	00*00*00 & 00 Kg.
Drawed By	İ.TOMBUL
Approved By	D.GÜL
Date	04.04.2022
Color	RAL 5009

MATERIAL DATA					
No	Connection	Model	Code	Material	Qty
1	Inlet Connection	ODS 1 1/8" H:55	106.060.B07.000.011	ST44-E275	1
2	Outlet Connection	ODS 1 1/8" H:55	106.060.B07.000.012	ST44-E275	1
3	Extra Outlet Connection	ODS 1 1/8" H:55	106.060.B07.000.012	ST44-E275	1
4	Safety Valve Conn.	NPT 1/2" H:18	106.060.F04.000.001	E275-ST44	1
5	Blind Plug	NPT 1/2" Plug	106.130.F04.001.001	E275	1
6	Sight Glass Type Conn.	SG-SW38	106.0SW.038.001.040	E275	3
7	Sight Glass	SW38	SW-38	E275	3
8	Outlet Pipe	Ø28,5x1,5	204.A28.015.000.255	EN10297-1-E235	2
9	Shell	Ø406x8	204.V10.60B.100.001	P355NH-EN10217-3	1
10	Head	Ø406x8 H:134	101.060.406.001.000	P355GH	1
11	Head	Ø406x8 H:134	201.060.406.001.001	P355GH	1
12	Skirt	Ø324x45	104.130.H45.415.324	S235	1
13	Base Plate	Ø270x8	105.005.415.001.002	S235	1
14	Label Plate	120x80x2	105.006.002.120.080	DD-13	1
15	Lifting	50x50x5	105.011.MPO.050.050	S235	1

GENERAL NOTES

- Max. allowable operating pressure (PS) according to the temperature range:
- 1) Allowable operating temperature : min. -20C° / max. +130C° PS1 = 60 Bar
- 2) Allowable operating temperature : min. -20C° / max. -40C° PS2 = 45 Bar
- Unless otherwise specified dimensions in MM
- Unless otherwise specified do not scale
- Unless otherwise specified tube must be clean&free from burrs inside&outside&uitable for soldering
- Unless otherwise specified do not scale indicated thickness are min. after forming or machining
- Unless otherwise specified dimension tolerances according to EN 113445-4

REVISIONS			
No	Details Of Change	Date	By
01			
02			
03			

RELATED DRAWINGS		
No	Description	Drawing No
01		
02		



We reserve all rights in this document and in the information contained therein. Reproduction use or disclosure to third parties without express authority is strictly forbidden.

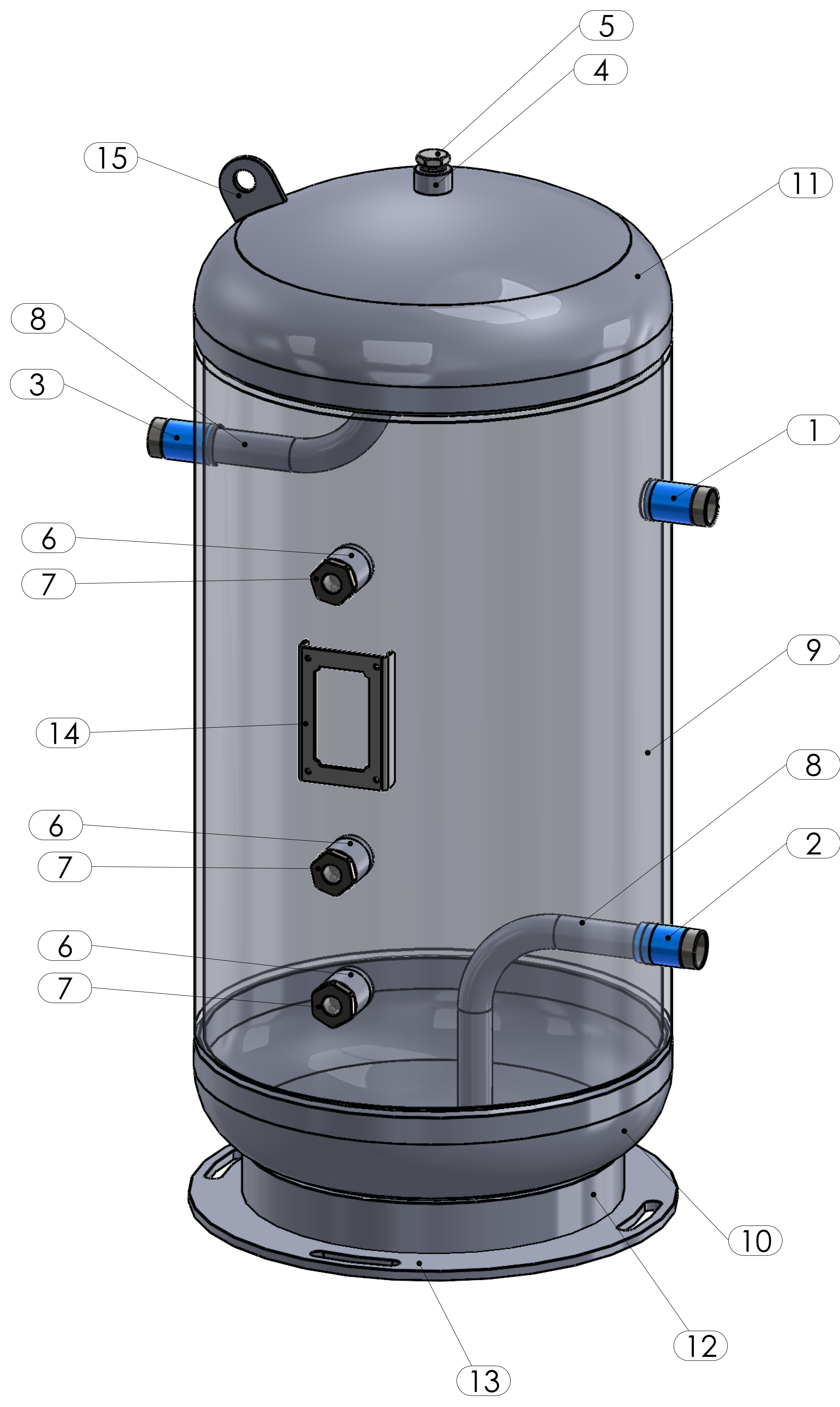
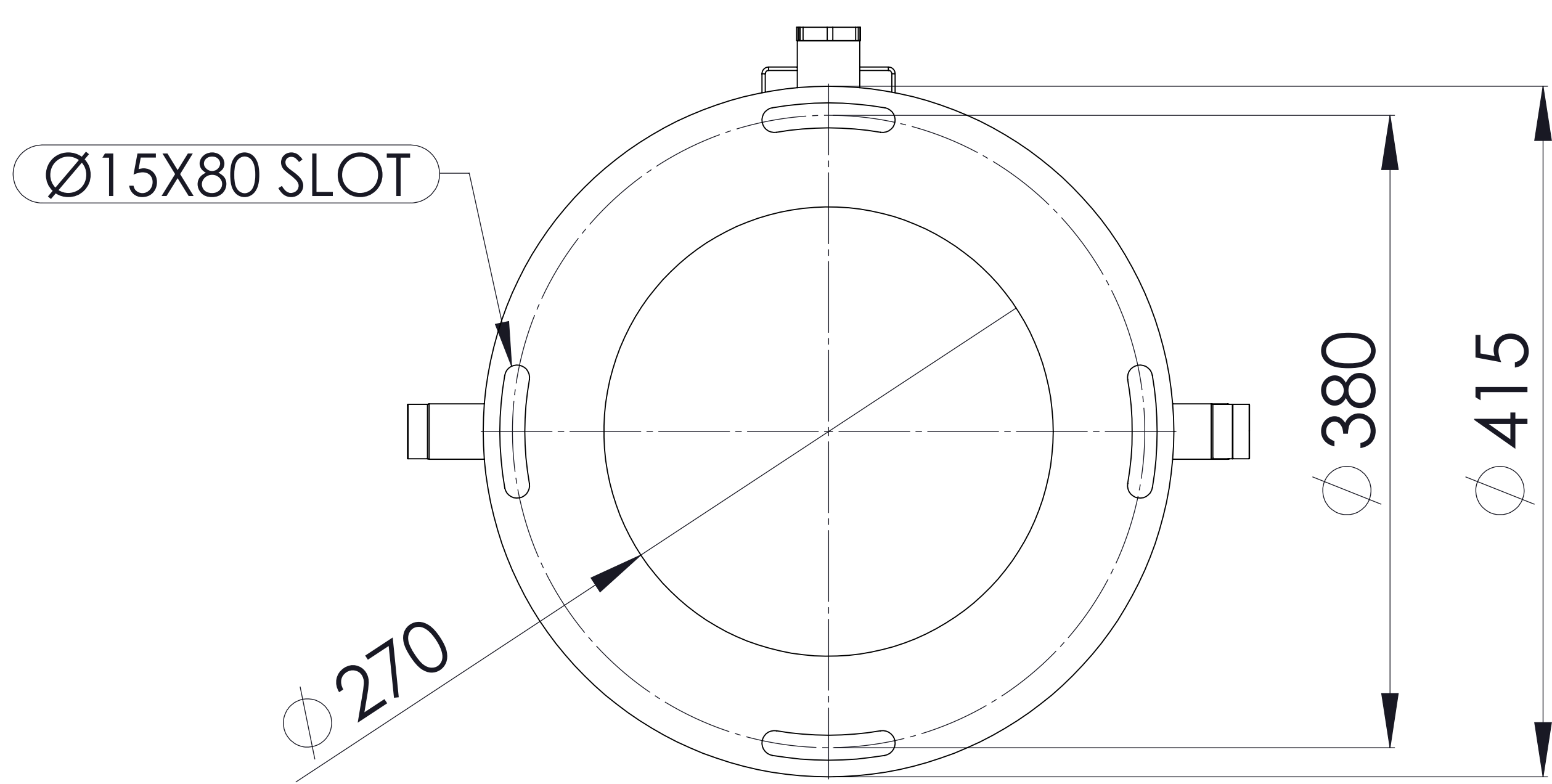
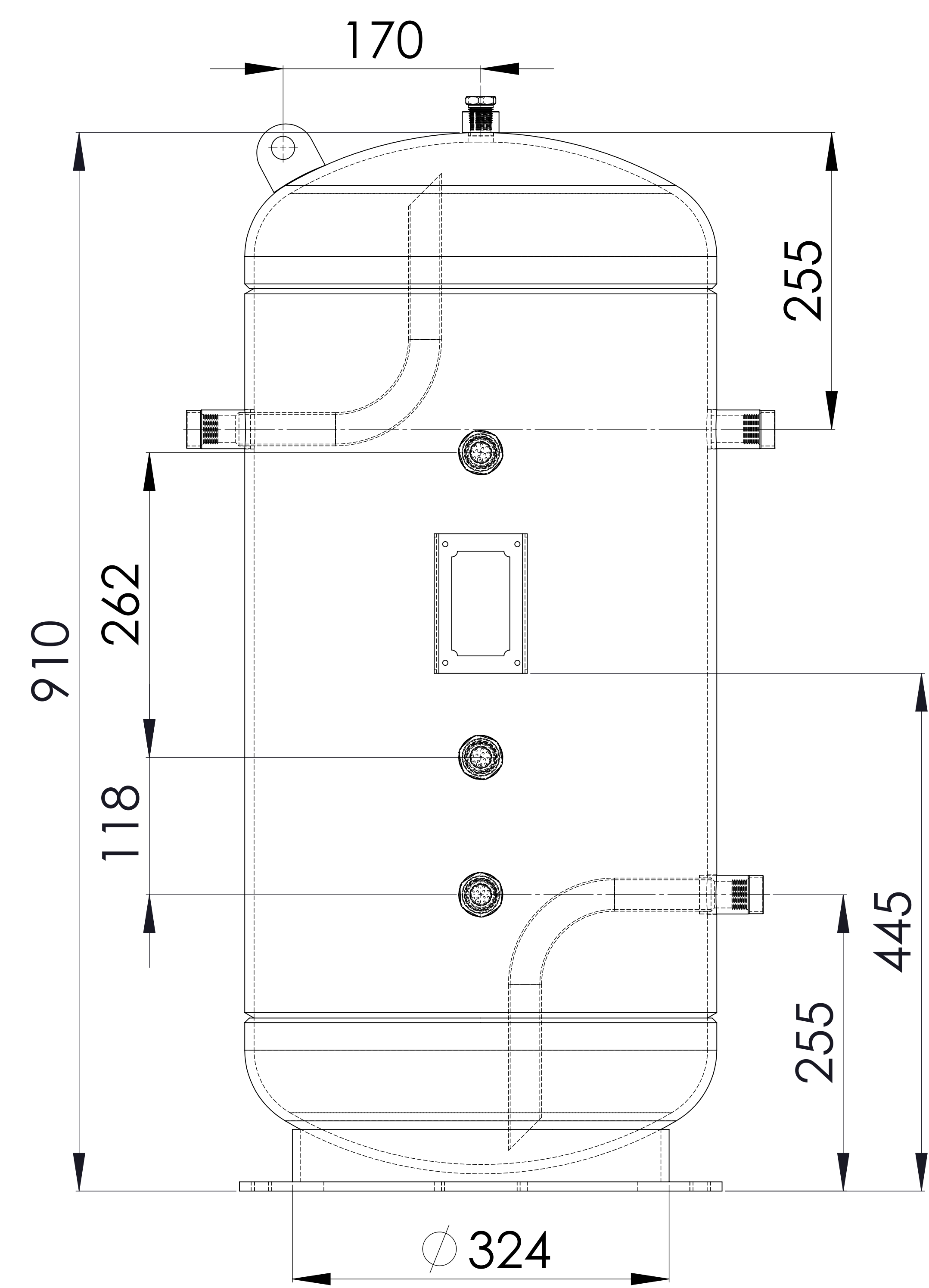
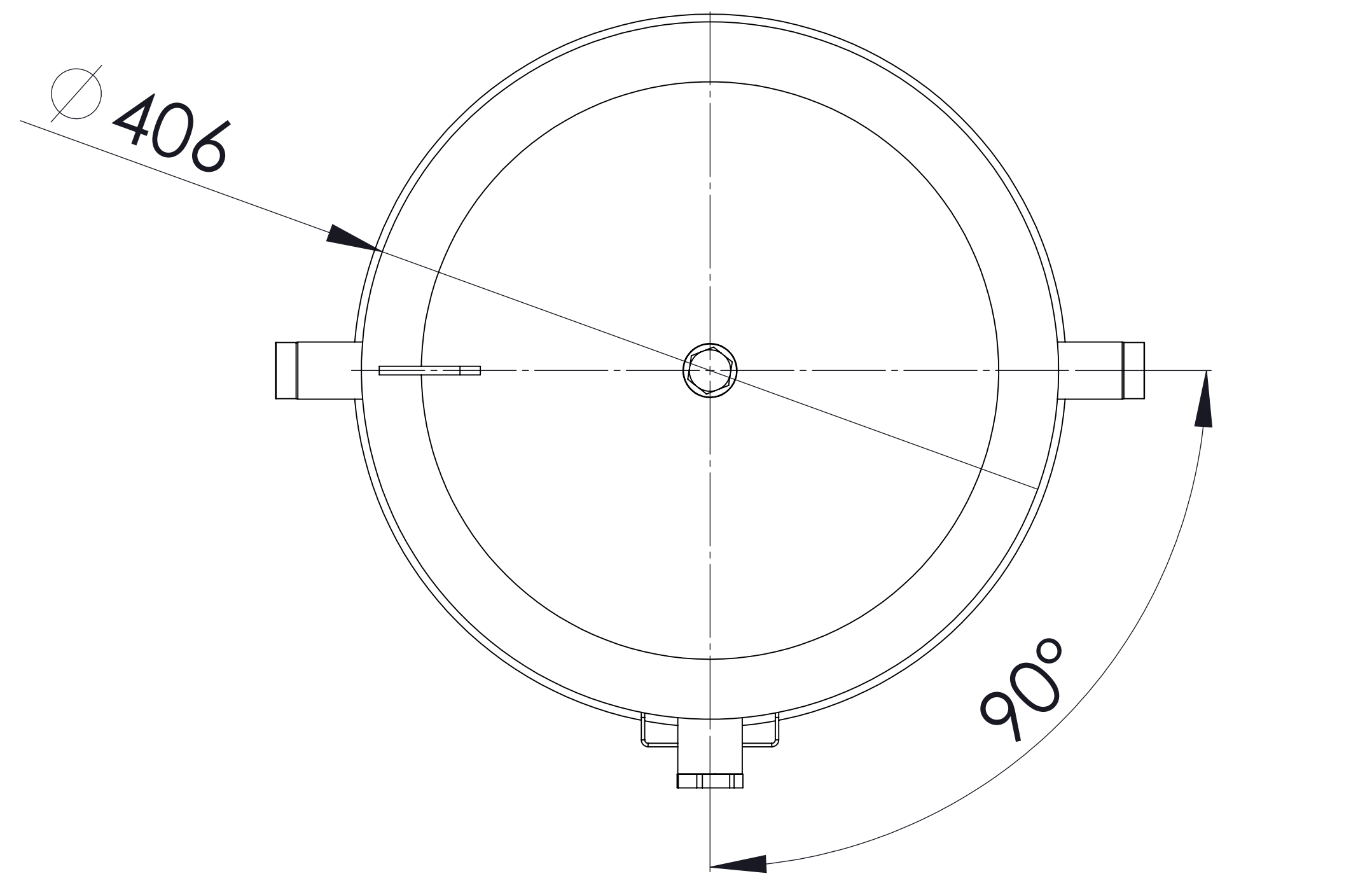

No	Assembly Codes	Qty
1	M005.000114	1