

BOTTOM VIEW

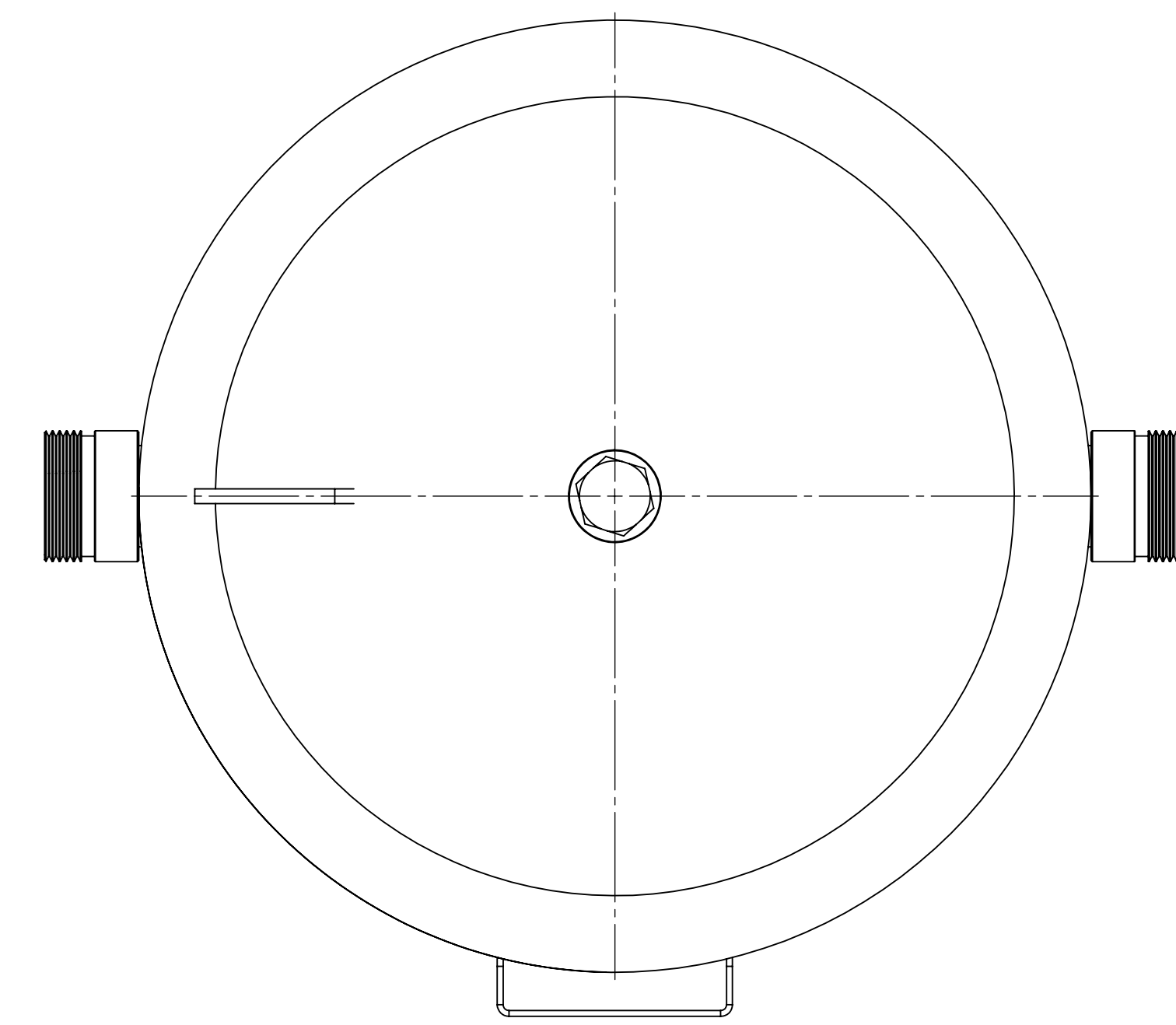

TOP VIEW

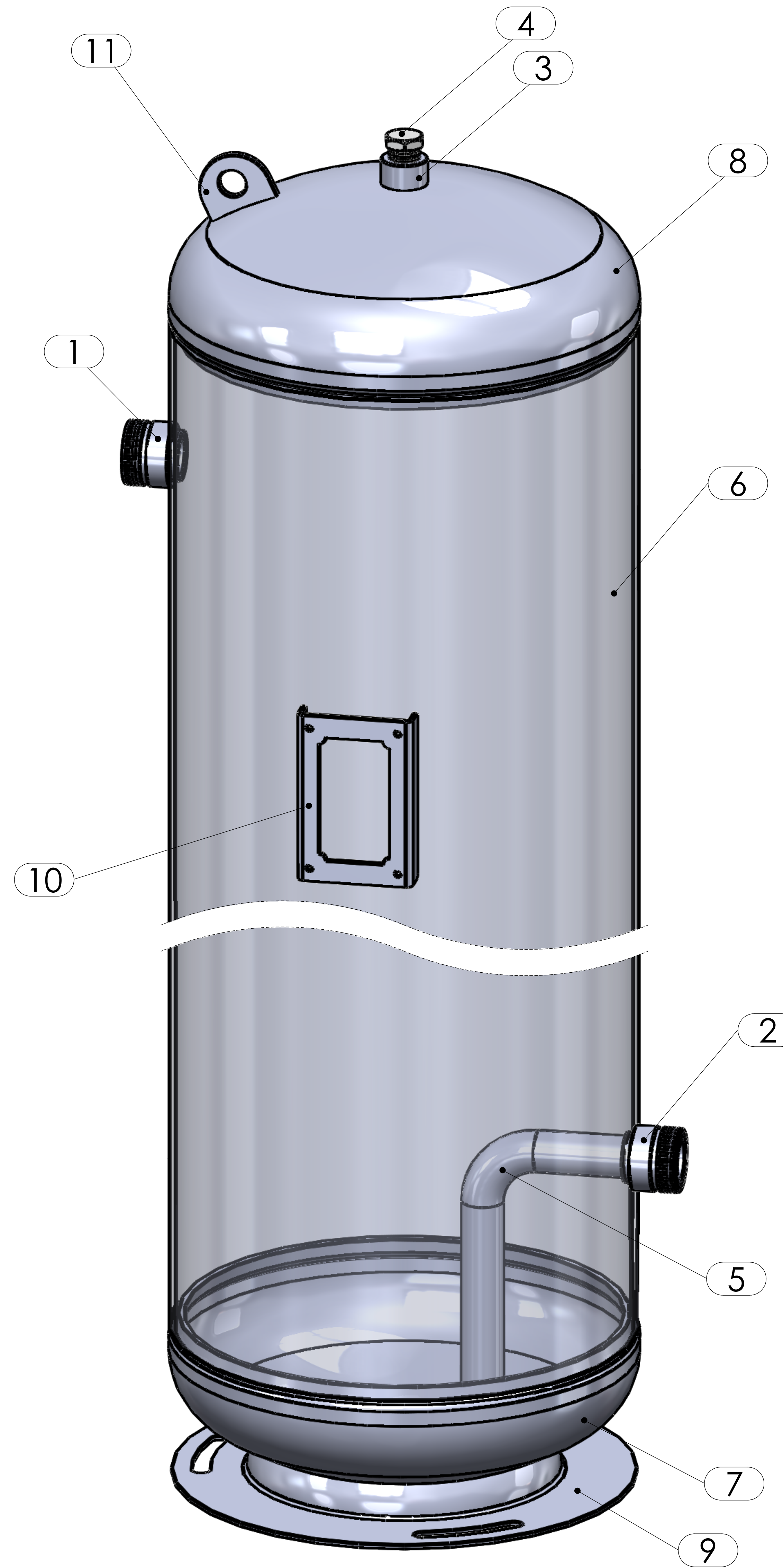

GÜVEN SOĞUTMA
ÜNİTELERİ SAN. VE TİC. A.Ş.

Addr: Hastane Mah. Hadimköy İstanbul Cd. No:78/1
34555, Arnavutköy, İstanbul, TURKEY
Tel: +90 212 771 51 12 - 771 51 13
Fax: +90 212 771 51 10
www.gvn.com.tr



GVN STANDART PRODUCT **Customer**

VERTICAL LIQUID RECEIVERS **Product**

V9A.33b.70.A4.A4.F4 **Code**

Customer Code

DESIGN DATA

Capacity [Lt.]	70 Lt.
Design Pressure [PS]	33 Bar
Pneumatic Test Pressure [PT]	36 Bar
Hydraulic Test Pressure	48 Bar
Design Temperature [TS]	Min.-20C / Max.+130C
Cooler Fluid Type	HFC-CFC-HCFC
Fluid Group	2
Category	CAT III / H
Desing Calculation	EN 14276-1/EN 13445-3
Welded Joint Efficiency	0.85
Material Group (Shell / Head)	1.2
Testing Group	3b
Corrasion Allowance	0,5 mm
Ndt	10%
Packaging Size & Weight	00*00*00 & 00 Kg.
Drawed By	Ö.TÜRKER
Approved By	D.GÜL
Date	22.03.2022
Color	RAL 5009

MATERIAL DATA

No	Connection	Model	Code	Material	Qty
1	Inlet Connection	ROT.1 3/4" H:32	106.060.A04.001.001	E 275	1
2	Outlet Connection	ROT.1 3/4" H:32	106.060.A04.001.001	E 275	1
3	Safety Valve Conn.	NPT 1/2" H:18	106.060.F04.000.001	E275-S144	1
4	Blind Plug	NPT 1/2" Plug	106.130.F04.001.001	E275	1
5	Pipe	Ø28,5X1,5	204.A28.015.000.240	E235	1
6	Shell	Ø323,9x4 H:764	204.V09.33B.070.001	EN10217-3 P355NH	1
7	Head - Torispheric	Ø323,9x4 H:100	101.033.324.001.000	P355GH EN 10028-2	1
8	Head Torispheric	Ø324x4 H:100	201.033.324.001.001	EN10217-3 P355NH	1
9	Skirt With	Ø320x2,5 H:27	105.004.320.001.001	EN 10111 DD-13	1
10	Label Plate	120x80x2	105.006.002.120.080	DD-13	1
11	Lifting	50x40	105.011.MP0.050.040	S235	1

GENERAL NOTES

- Max. allowable operating pressure (PS) according to the temperature range;
- 1) Allowable operating temperature : min. -20C° / max. +130C° PS1 = 33 Bar
- 2) Allowable operating temperature : min. -20C° / max. -40C° PS2 = 24 Bar
- Unless otherwise specified dimensions in MM
- Unless otherwise specified do not scale
- Unless otherwise specified tube must be clean&free from burrs inside&outside&uitable for soldering
- Unless otherwise specified do not scale indicated thickness are min. after forming or machining
- Unless otherwise specified dimension tolerances according to EN 113445-4

REVISIONS

No	Details Of Change	Date	By
01			
02			
03			

RELATED DRAWINGS

No	Description	Drawing No
01		
02		



No	Assembly Codes	Qty
1	M005.000068	1

We reserve all rights in this document and in the information contained therein. Reproduction use or disclosure to third parties without express authority is strictly forbidden.