

GÜVEN SOĞUTMA
ÜNİTELERİ SAN. VE TİC. A.Ş.

Addr.: Hastane Mah. Hadimköy İstanbul Cd. No:78/1
34555, Arnavutköy, İstanbul, TÜRKİY
Tel: +90 212 771 51 12 - 771 51 13
Fax: +90 212 771 51 10
www.gvn.com.tr



GVN STANDART PRODUCT **Customer**

VERTICAL LIQUID RECEIVER **Product**

VLR.A.30b.05.B2.C2 **Code**

Customer Code

DESIGN DATA

Capacity [Lt.]	5 Lt.
Design Pressure [PS]	30 Bar
Pneumatic Test Pressure [PT]	33 Bar
Hydraulic Test Pressure	43 Bar
Design Temperature [TS]	Min.-20C / Max.+130C
Cooler Fluid Type	HFC-CFC-HCFC
Fluid Group	2
Category	CAT I / A
Desing Calculation	EN 14276-1/EN 13445-3
Welded Joint Efficiency	0.85
Material Group (Shell / Head)	1.2
Testing Group	3b
Corrasion Allowance	0,5 mm
Ndt	10%
Packaging Size & Weight	00*00*00 & 00 Kg.
Drawed By	Ö.TÜRKER
Approved By	D.GÜL
Date	20.06.2022
Color	RAL 5009

MATERIAL DATA

No	Connection	Model	Code	Material	Qty
1	Inlet Connection	ODS 3/8" H:30	106.060.B02.000.004	ST44-E275	1
2	Outlet Connection	ROT. 1" H:25	106.060.A02.001.001	E275-ST44	1
3	Outlet Valve	RV.45b-3/8			1
4	Pipe	Ø13x1	204.A13.010.000.220	EN 10297-1 E235	1
5	Deep Drawn	Ø160x2,5 H:145	203.050.001.001.001	EN 10111-DD-13	1
6	Deep Drawn	Ø160x2,5 H:145	103.050.002.001.000	EN 10111-DD-13	1
7	Skirt With	Ø162x2,5 H:18	105.004.162.001.001	DD-13	1

GENERAL NOTES

-Max. allowable operating pressure (PS) according to the temperature range;
1) Allowable operating temperature : min. -10C° / max. +100C° PS1 = 33 Bar
2) Allowable operating temperature : min. -10C° / max. -40C° PS2 = 24 Bar
-Unless otherwise specified dimensions in MM
-Unless otherwise specified do not scale
-Unless otherwise specified tube must be clean&free from burrs inside&outside&uitable for soldering
-Unless otherwise specified do not scale indicated thickness are min. after forming or machining
-Unless otherwise specified dimension tolerances according to EN 113445-4

REVISIONS

No	Details Of Change	Date	By
01			
02			
03			

RELATED DRAWINGS

No	Description	Drawing No
01		
02		



We reserve all rights in this document and in the information contained therein. Reproduction use or disclosure to third parties without express authority is strictly forbidden.

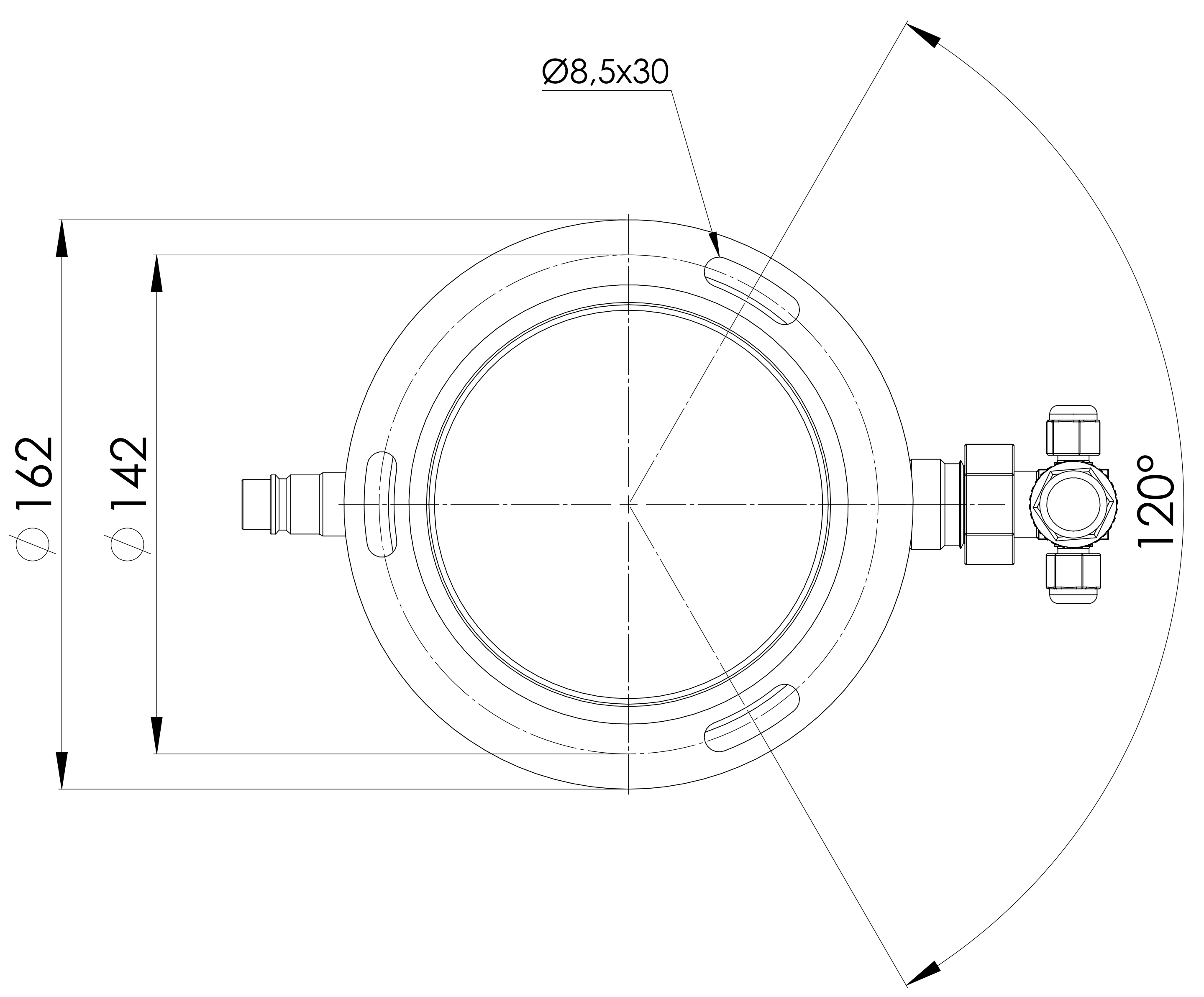
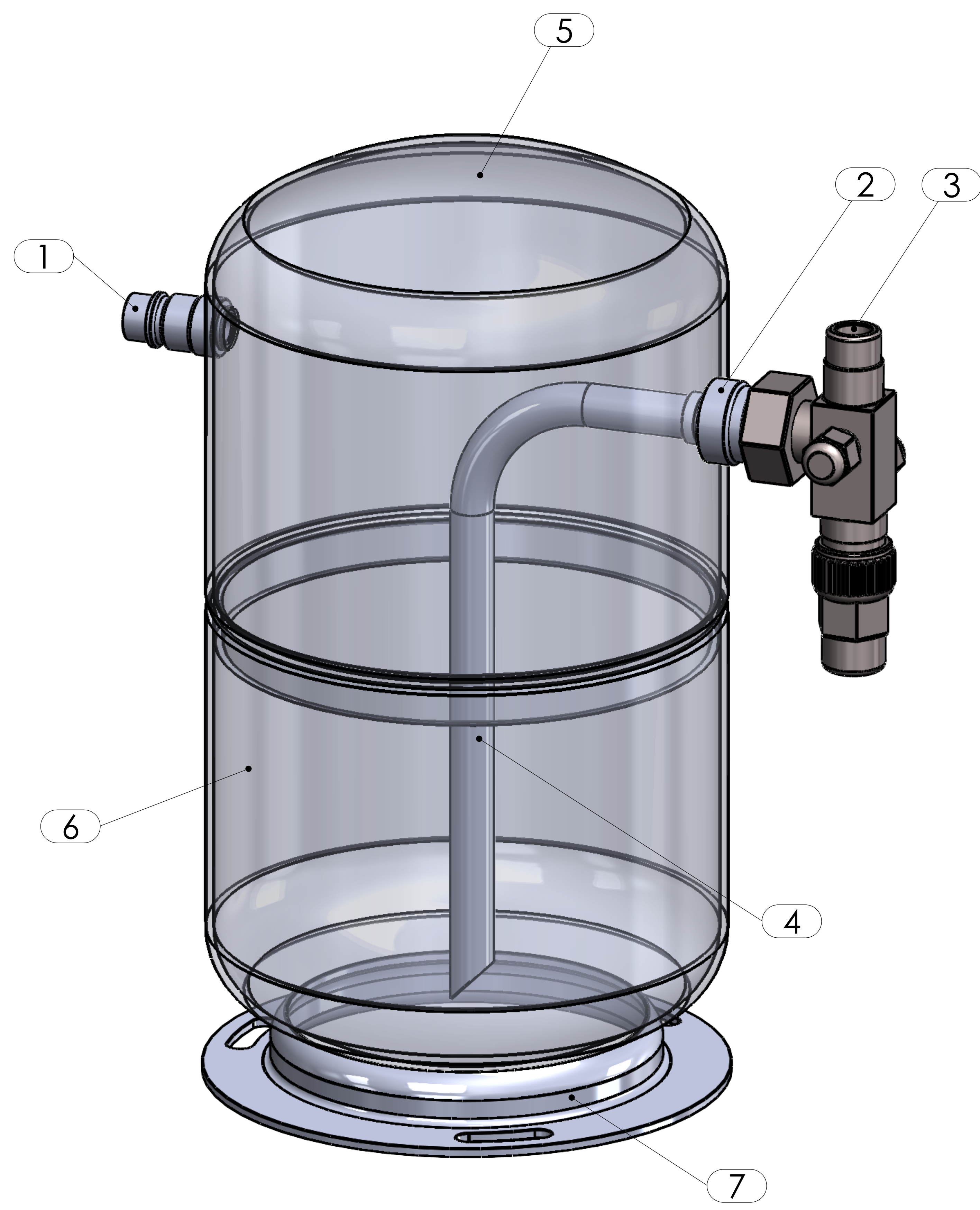
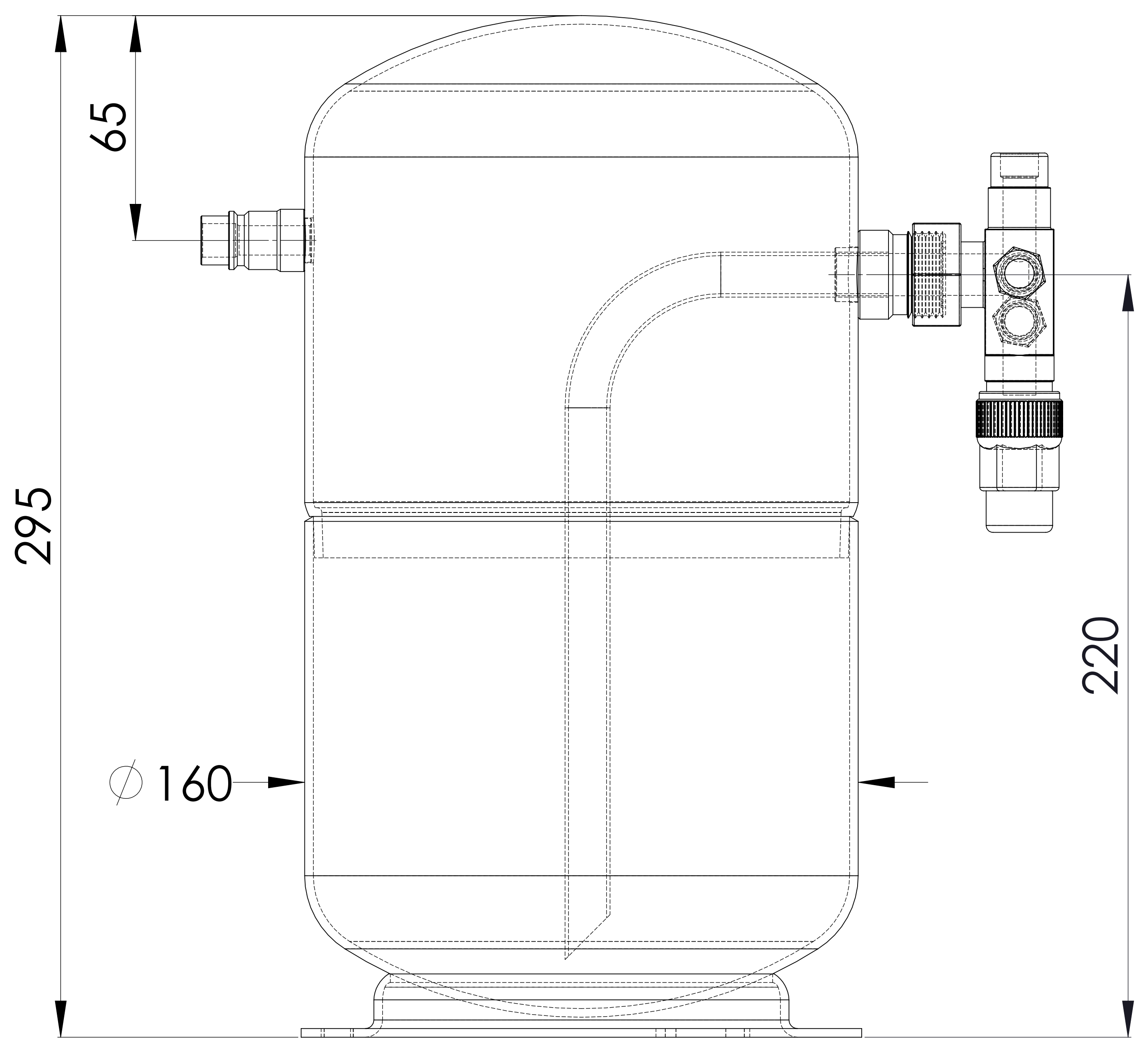

No	Assembly Codes	Qty
1	M005.000020	1