

Yolculuk Bizimle Başlar!

DOMETIC Whale

BABARVY ALKO Eberspächer

LIPPERT truma indelB

THULE SWEDEN victron energy BLUE POWER

SOLARA module. komponenten. systeme CBE Fischer Panda

THETFORD ARANA

COMET SMART • EQUIPMENT • SOLUTIONS ACRYFORM PLASTOFORM autoterm

POLYPLASTIC Linetech ECOFLOW Bio

ABL SANJO ilse REICH jokon Competence in Lighting

FIAMMA EP Kampa



Markalar üzerine tıklayarak ilgili kataloğa ulaşabilirsiniz.

Introduction

Application examples



Automotive

The automotive market comprises a broad range of applications requiring a reliable power supply. In vehicles such as fire engines, ambulances and police cars a human life may depend on an autonomous system. So it is vital that all systems function flawlessly. Victron Energy offers you such an answer. We are proud to offer you our modern translation for freedom and independence. Energy. Anytime. Anywhere.

Autonomous systems

Our products are being used in all vehicles requiring an extra power supply, for example ambulances, firetrucks, police cars, motorhomes, service vehicles, luxurious horse trailers, military vehicles and broadcasting vehicles.



Motorhomes



Ambulances

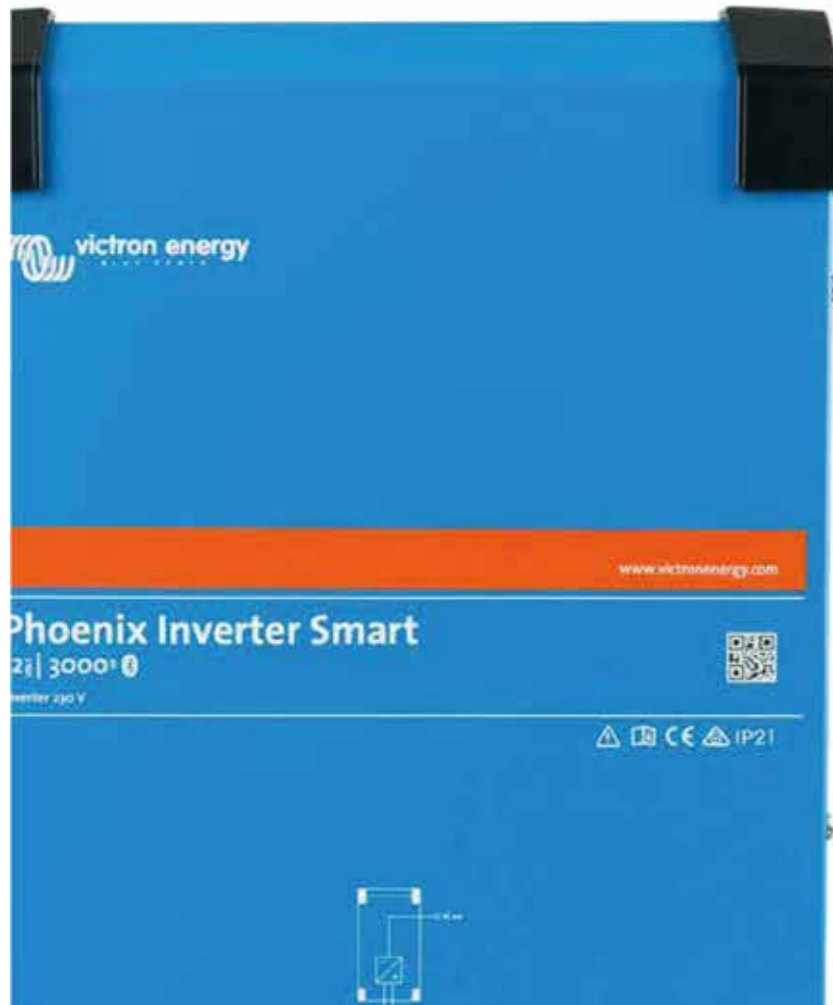

Coffee cart

[Application Examples](#)

[Motorhomes](#)

[Ambulances](#)

[Coffee cart Espresso](#)

[Systems](#)

[Accessories](#)

[Tools](#)

[Technical information](#)



On adventure with a motorhome
 For those who are looking for real adventure during their vacation, proper equipment and good transport are the basic needs. The Australian company 'SLR Caravans & Motorhomes' builds four wheel drive motor homes, expedition vehicles and caravans, especially made to withstand harsh Australian conditions.

Adventurer
 The most advanced vehicle for extreme conditions is the Adventurer 4x4 motorhome/expedition from SLR. This vehicle is the gateway to spectacular and usually inaccessible destinations all over the globe. Thanks to the purpose designed and engineered body, the Adventurer is capable of tackling tough terrain such as the desert, rivers, mountains and sandy roads.



Victron Energy equipment
 An almost indispensable option for the off-road vehicles is the Victron Phoenix MultiPlus: a powerful true sine wave inverter. In the event of generator power being disconnected, the inverter within the Multi is automatically activated and takes over the supply to the connected loads. So even in the middle of nowhere the off-road vehicles are assured of a reliable power supply.



The inverter converts 12 Volt power to 240 Volt power, which can be used for appliances such as the air conditioner, microwave, washing machine, refrigeration compressor, etc. The higher Watt units provide even more 'start up power', which is generally required by these appliances.





The company Petit Picot has installed MultiPlus 12/1600/70 in ambulances in the Parisian region. The MultiPlus provides a pure sinusoidal 230 volt alternating current power supply for the different medical devices (incubators, monitors, defibrillators, etc.) on board. These important medical devices need to be operational at all times. The MultiPlus UPS function provides the ambulances a 230Vac permanent power supply.

So an ambulance can function whether it is connected to the mains when idle or in autonomous mode when driving. With the MultiPlus on board it has been possible to simplify wiring, compared with a separately installed inverter and charger, with the consequent cost saving in the installation.



Global market leader in ambulances

Victron Energy is global market leader in power supply equipment for ambulances. Our products are considered to be very reliable and extremely suitable for rescue vehicles such as ambulances.

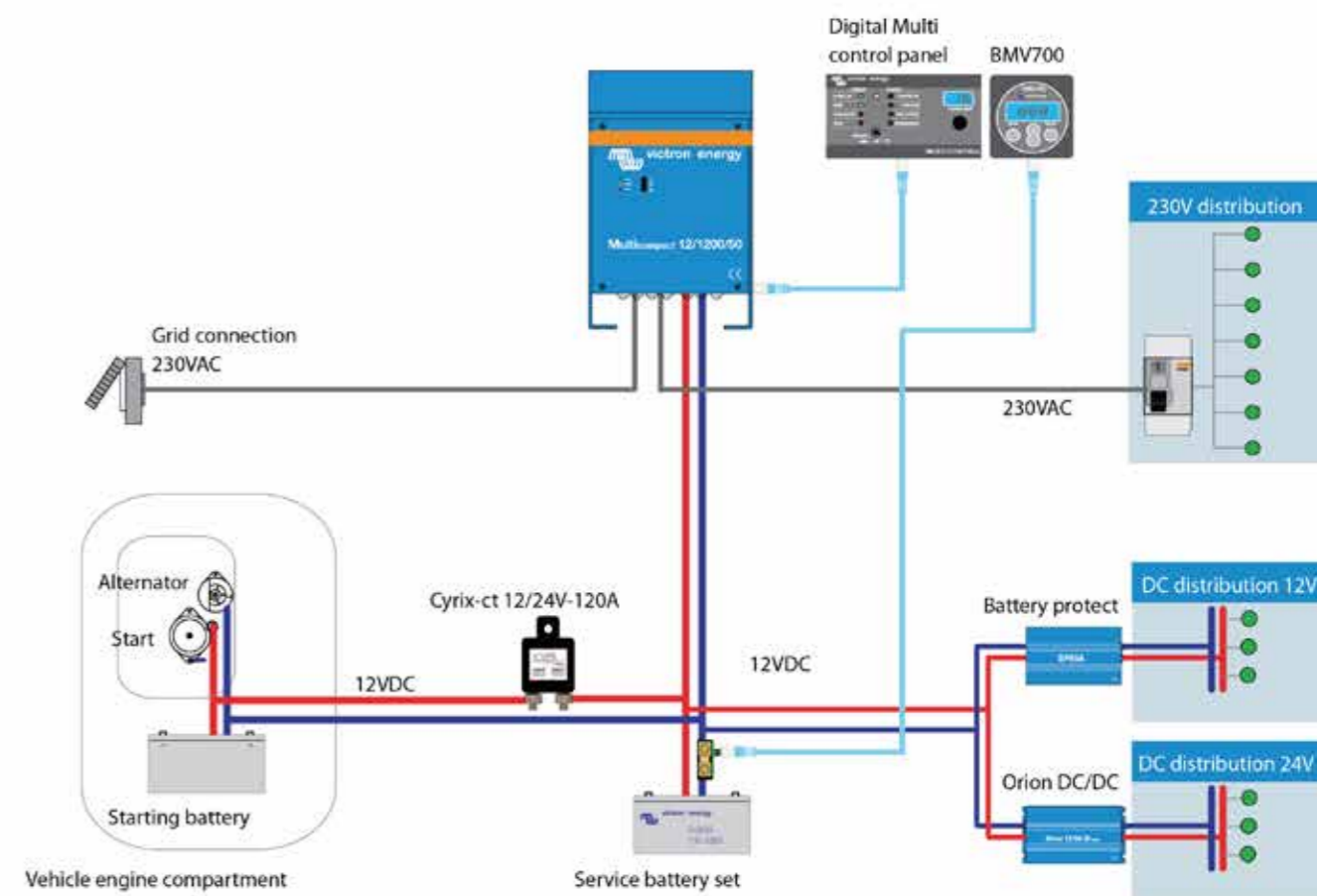

Schematic overview of the installation in the ambulances in Paris.



Coffee cart

Dutch-based company Espresso, which rents out various types of mobile espresso machines, has developed a coffee cart that is powered exclusively by electricity. The coffee cart can be driven and operated on electricity and used in any location, thanks to its on board equipment. The electric coffee cart can be used for a diversity of events: weddings, openings, business functions, exhibitions, festivals and conferences.

Victron equipment

To ensure that the coffee cart can be operated without any need whatsoever for mains electricity, the vehicle is equipped with the following:

- 1 x Quattro 48V 10kVA
- 1 x Battery Monitor BMV-700
- 48V 1000A OPzV batteries

Devices

The following devices are powered by the electricity stored in the batteries:

- Coffee machine
- Refrigeration system
- Sun screen
- Coffee grinder
- Lighting
- The vehicle's drive system

The coffee cart has a special switch to operate the electrical devices and the vehicle's drive system separately and so avoid using too much electricity at the same time.

Consumption

When the batteries are fully charged, the coffee cart can make coffee for up to 5 hours. That equates to around 1000 cups of coffee. When all devices are running simultaneously the total power consumption is 8kW.

When the coffee machine is not being used, the coffee cart has a range of 300 kilometres.

The Battery Monitor checks on how full the batteries are so that the coffee cart is always able to get back home.

Go to www.espressi.nl to find out more about Espresso's coffee carts.



1. Simple system with only DC consumers

The battery charger charges the battery and functions as a power supply for the consumers.

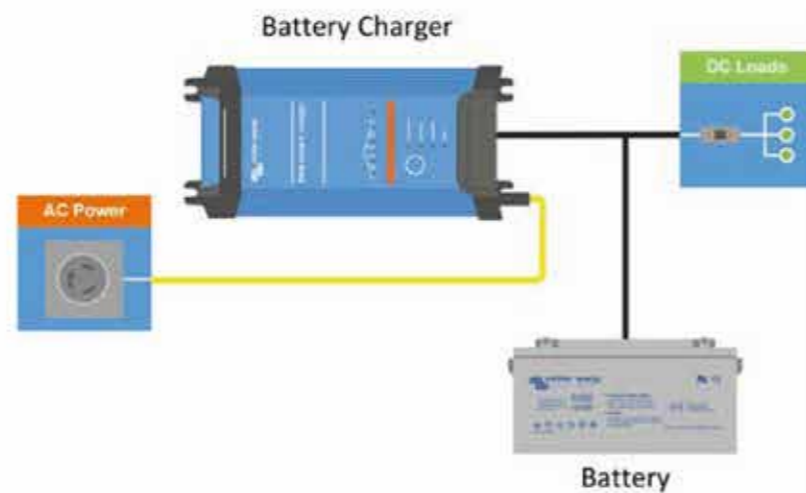

2. Charger system with inverter

This system contains a charger with three isolated outputs in order to charge three isolated battery banks. The inverter in this system provides 230VAC loads.

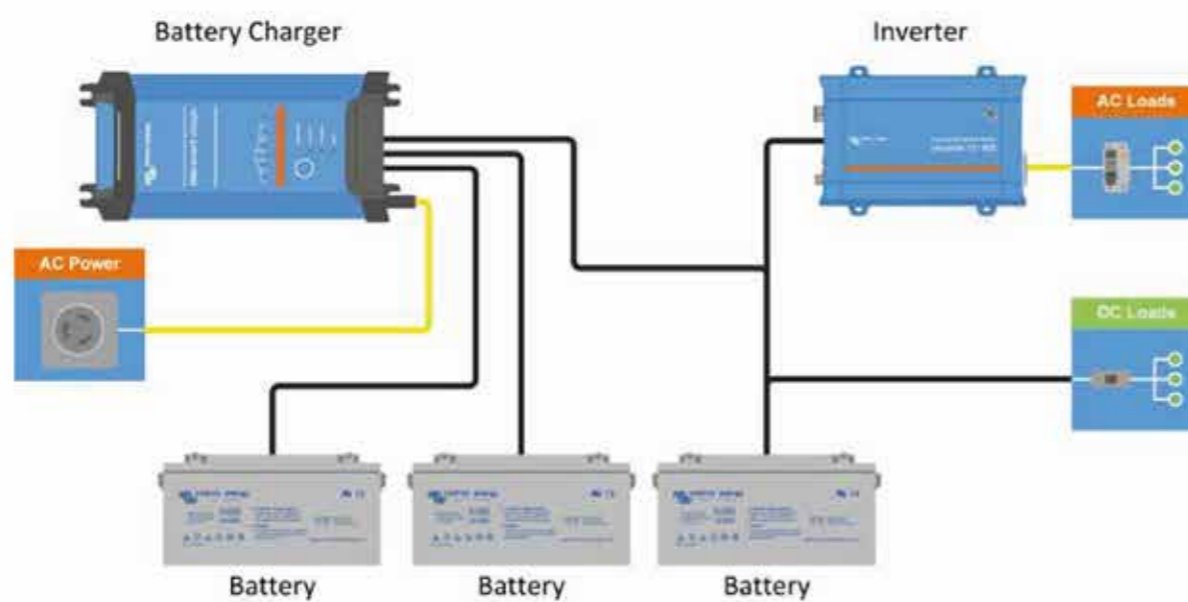

3. Multi system

The MultiPlus combines the charger and inverter functionality. This will result in easy installation and features like PowerControl and PowerAssist.

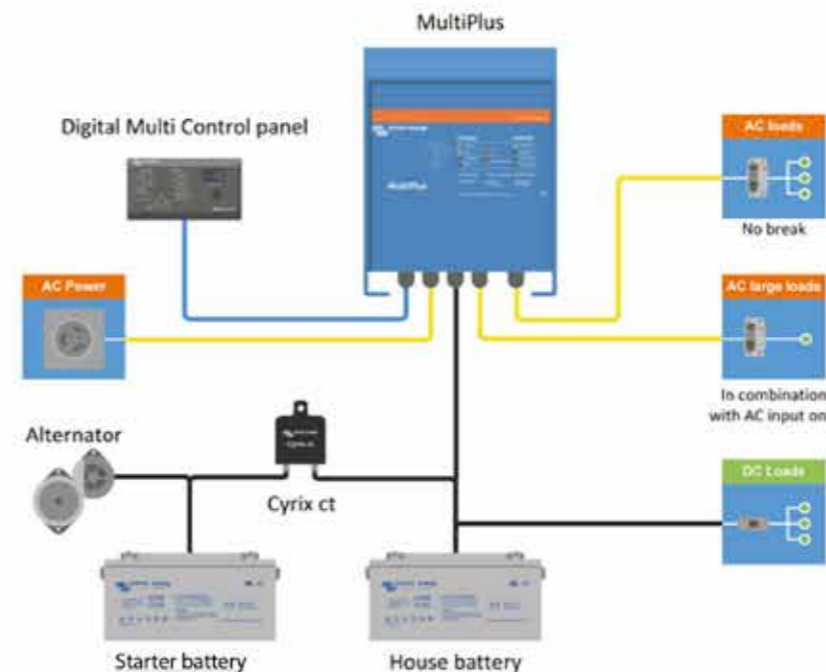

MultiPlus vs Quattro

The MultiPlus and Quattro products play a central role in both AC and DC systems. They are both powerful battery chargers and inverters in one box.

The amount of available AC sources is the deciding factor when choosing between the Quattro and the Multi.

The big difference is that a Quattro can take two AC sources, and switch between them based on intelligent rules. It has a built-in transfer-switch. The MultiPlus can take only one AC source.

4. Quattro system

The Quattro has the same functions as the MultiPlus, but with an extra addition: a transfer system which automatically selects the available input.

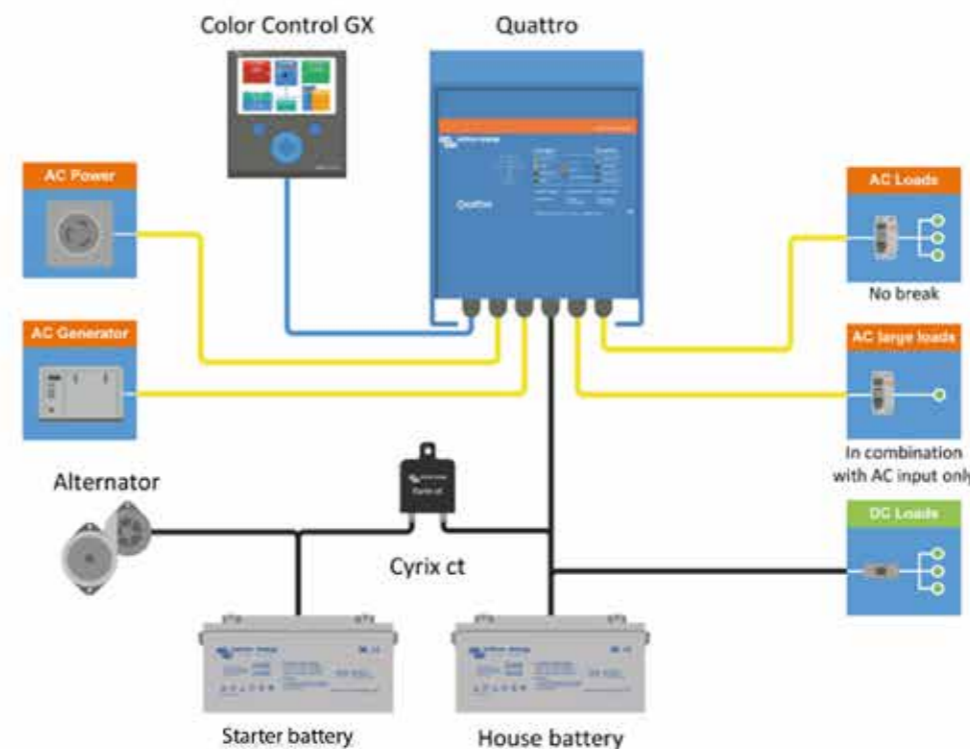

- [Application Examples](#)
- [Motorhomes](#)
- [Ambulances](#)
- [Coffee cart Espresso](#)
- [Systems](#)
- [Accessories](#)
- [Tools](#)
- [Technical information](#)

5. Parallel system

Our inverters, Multis and Quattros can be paralleled to meet higher power requirements. A simple setting with our VEConfigure configuration software is sufficient.

Easy to configure

Configuring parallel and three-phase systems is easy. Our VEConfigure software tool allows the installer to put components together, without any hardware changes or dipswitches. Just using standard products.

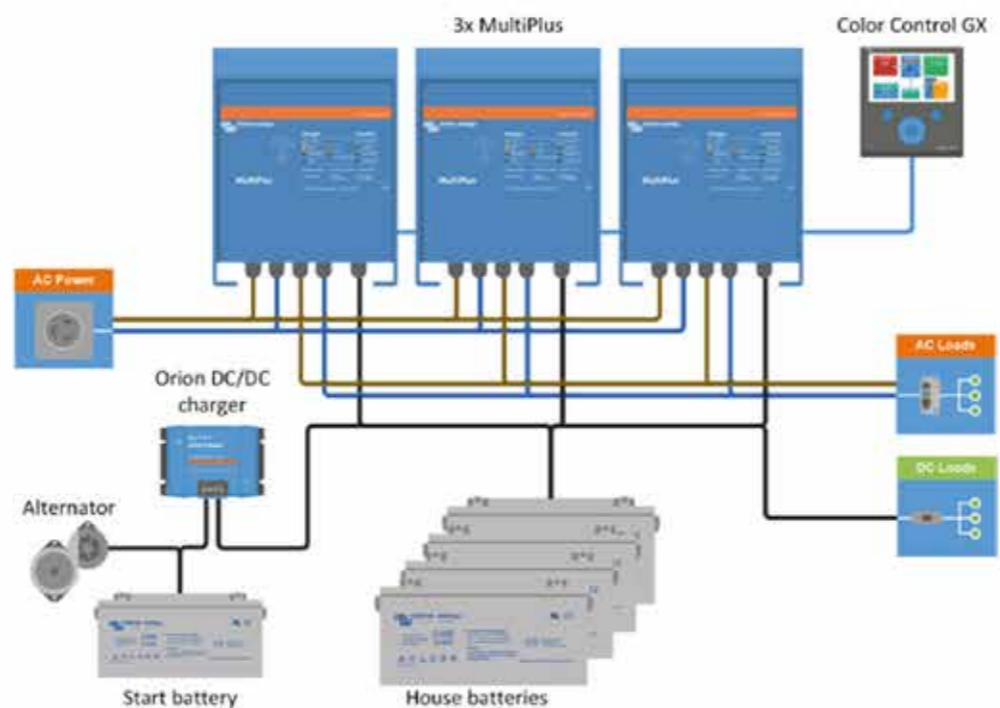

6. Three-phase system

Similar to connecting units in parallel they can also be connected in split-phase and three-phase configurations.

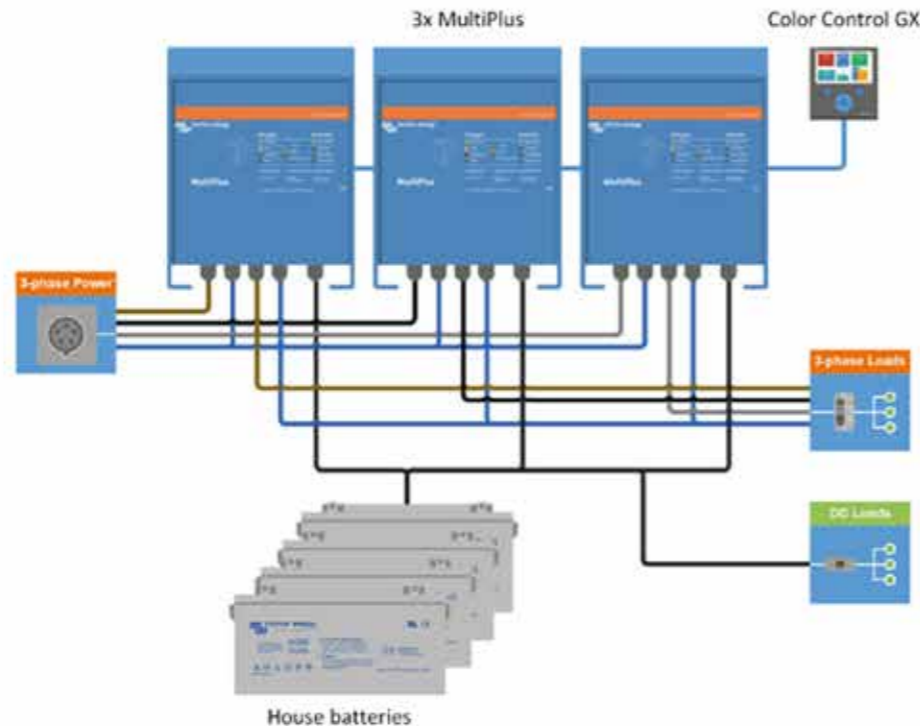

7. MultiPlus system with a solar panel

In this configuration the batteries are being charged by solar power, the alternator and AC power.

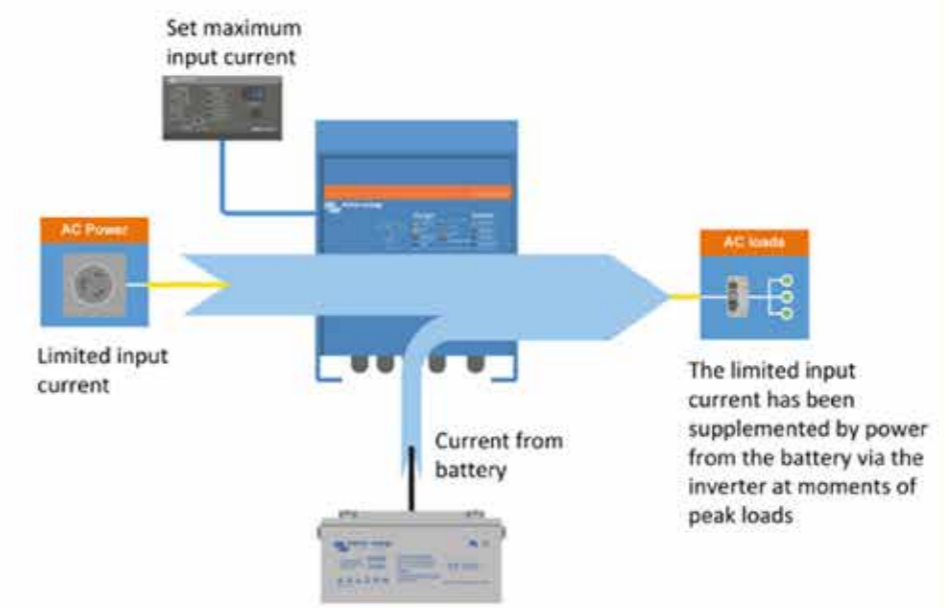
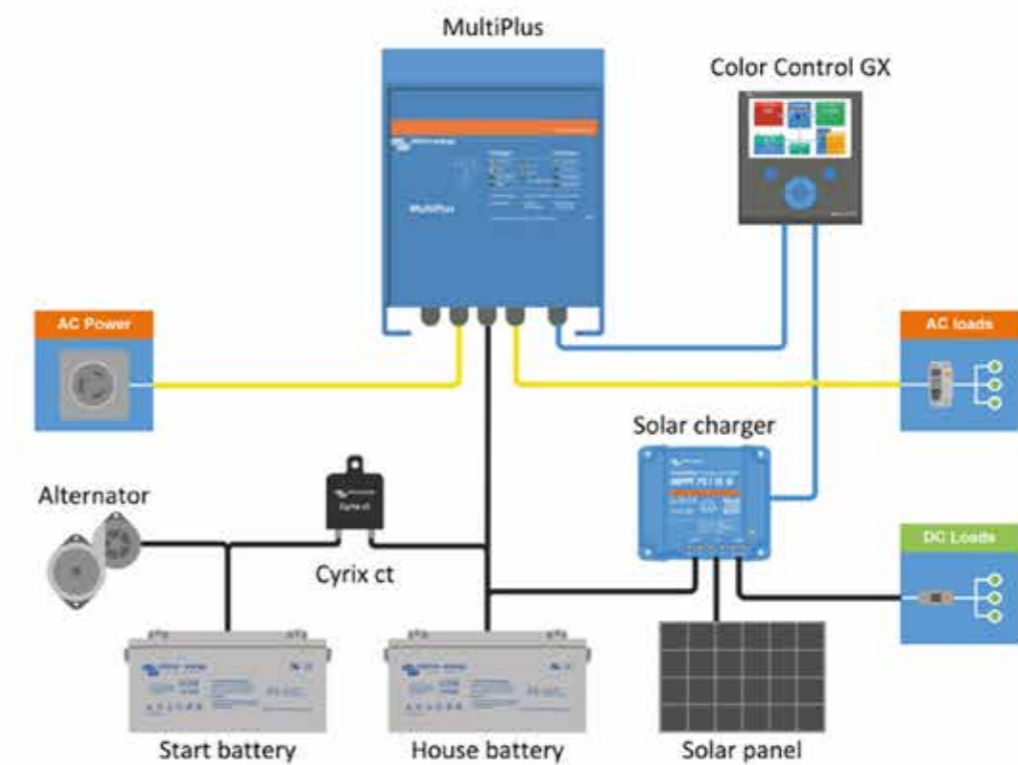

PowerAssist - boosting the capacity of AC or generator power

This unique Victron feature allows the MultiPlus to supplement the capacity of the mains or generator power. Where peak power is so often required only for a limited period, the MultiPlus will make sure that insufficient mains or generator power is immediately compensated with power from the battery. When the load reduces, the spare power is used to recharge the battery bank.

It is therefore no longer necessary to size a generator on the maximum peak load. Use the most efficient size generator instead.

Note: this feature is available in both the MultiPlus and the Quattro.

Accessories

Our systems are comprised of various components. Some of which are specifically designed for specific markets. Other Victron components are applicable for a wide range of applications. You are able to find the specifications and other detailed information about these components in the 'Technical Information' section.



Battery Monitor

Key tasks of the Victron Battery Monitor are measuring charge and discharge currents as well as calculating the state-of-charge and time-to-go of a battery. An alarm is sent when certain limits are exceeded (such as an excessive discharge). It is also possible for the battery monitor to exchange data with the Victron Global Remote. This includes sending alarms.



Filax 2: the ultra fast transfer switch

The Filax has been designed to switch sensitive loads, such as computers or modern entertainment equipment from one AC source to another. The priority source typically is the mains, a generator or shore power. The alternate source typically is an inverter.



Color Control GX

The Color Control GX provides intuitive control and monitoring for all products connected to it. The list of Victron products that can be connected is endless: Inverters, Multis, Quattros, MPPT 150/70, BMV-600 series, BMV-700 series, Skylla-i, Lynx Ion and even more. The Color Control GX is now also equipped with a generator start/stop function using the internal relay. Besides monitoring and controlling products on the Color Control GX, the information is also forwarded to our free remote monitoring website: the VRM Online Portal.



BatteryProtect Models 12/24V: 65A, 100A & 220A Model 48V: 100A

The BatteryProtect disconnects the battery from non-essential loads before it is completely discharged (which would damage the battery) or before it has insufficient power left to crank the engine.



GX Touch 50

The GX Touch 50 is the display accessory for our Cerbo GX. The five inch touch screen display gives an instant overview of your system and allows to adjust settings in the blink of an eye. Simply connected to the Cerbo GX with one cable, its super slim waterproof design, top-mountable setup and its simple installation bring a lot of flexibility when creating a crisp and clean dashboard.



Shore power cable

Waterproof Shore Power Cable and Inlet IP56
Moulded Plug and Connector
Power indication LED
Protection Cap
Stainless Steel Inlet



Digital Multi Control Panel GX

With this panel you are able to remotely monitor and control MultiPlus and Quattro systems. A simple turn of the button can limit the power supply of for example a generator and/or shore-side current. The setting range is up to 200A.

Tools

We have a couple of tools available that make it easy for Victron distributors, installers and customers to work with Victron Energy products. Whether you want to configure and read out your Victron products with VictronConnect using your smartphone, tablet or computer or you want to show your VRM site to friends and family, it is all possible with these Victron tools.



VRM Online Portal: Remotely monitor Victron equipment
 Victron Remote Management (VRM) is provided by Victron Energy to remotely monitor electrical equipment all over the world. Once you have a VRM account you will be able to view live feed from your installation, such as generated solar energy, state of charge of your batteries and the consumption.

To get an impression of the VRM Online Portal, please visit: <https://vrm.victronenergy.com> and use the 'Take a look inside' button. The portal is free of charge.



Victron Community

The Victron Community is a place for questions and answers about Victron related subjects.
<https://community.victronenergy.com/>



Instruction videos on Victron youtube channel

On our YouTube channel you can watch Victron Energy instruction videos.
<https://www.youtube.com/user/VictronEnergyBV>



VictronConnect

VictronConnect lets you get live status info and configure Victron products with built-in Bluetooth support, such as the SmartSolar and the Blue Smart IP65 Charger, or using a VE.Direct Bluetooth Smart dongle or VE.Direct USB interface. Firmware updates are included inside VictronConnect.

VictronConnect is available for both Windows PCs, Max OS X, IOS and Android phones as well as tablets. Download VictronConnect from our software page: <https://www.victronenergy.com/support-and-downloads/software#victronconnect-app>



Victron Energy Blog

On the Victron Energy Blog you can read about the latest news, new products and a lot of success stories with Victron Energy.

Subscribe to the Victron Energy Blog:
<https://www.victronenergy.com/blog/>

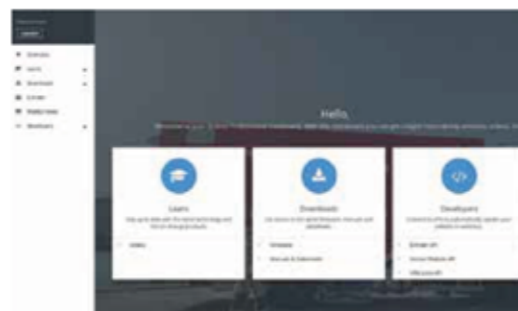

Victron Professional

Victron Professional is a new online portal, available to both distributors as well as other professionals and end users that work with Victron equipment.

With Victron Professional you can get insight into training sessions, videos, firmware files, APIs and the latest news. If you already use E-Order you can login with those credentials.

Sign up for Victron Professional here:
<https://professional.victronenergy.com>

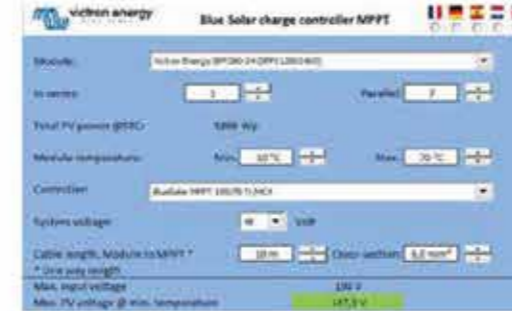

MPPT Calculator Excel sheet

With the MPPT Calculator Excel sheet you can match solar modules to MPPT charge controllers.

Download the Excel sheet from our software page:



VRM World: View shared VRM sites around the world

Ever wanted to show your clients, friends, colleagues how much solar energy your installation is generating or indeed any other data that you can see on your VRM site? Well now you can – using VRM World. You need a VRM account to be able to view shared VRM sites. In your VRM portal it is possible to publicly share on VRM World.

Visit VRM World here:
<https://vrm.victronenergy.com/world/>



Victron Live

Victron Live is a living and growing website, which is a constantly evolving information store. It is a place where you can find manuals for VEConfigure3, Assistants and other software and software products.

Visit Victron Live here:
<https://www.victronenergy.com/live/>



Campervan, the home of Pine van den Berg during her travels in Europe.

Note - for our newest datasheets please refer to our website: www.victronenergy.com

TECHNICAL INFORMATION

Phoenix inverters Smart 1600VA - 5000VA	22
Phoenix inverters 250VA - 1200VA VE-Direct	24
Phoenix inverters 1200VA - 5000VA 230V	26
MultiPlus inverter/charger 500VA - 1600VA	28
MultiPlus inverter/charger 800VA - 5kVA 230V	30
MultiPlus inverter/charger 2kVA and 3kVA 120V	32
Quattro inverter/charger 3kVA - 15kVA 230V	34
Quattro inverter/charger 3kVA - 10kVA 120V	36
Blue Smart IP22 charger	38
Blue Smart IP67 charger 230V	39
Blue Smart IP65 Charger with DC connector	41
Phoenix Smart IP43 charger	44
Centaur charger 12/24V	46
Phoenix battery charger 12/24V	48
Skylla-I battery charger 24V	50
Skylla TG charger 24/48V 230V	52
Orion-Tr Smart DC-DC charger non-isolated	54
Orion-Tr Smart DC-DC charger isolated	56
Orion-Tr DC-DC converters isolated: 100 / 250 / 400 Watt	58
Orion-Tr DC-DC converters, low power	60
Orion DC-DC converters	61
Orion IP67 24/12 and 12/24 DC-DC converters	62
Cerbo GX and GX Touch 50	64
Color Control GX	66
Venus GX	70
Buck-Boost DC-DC converter	74
Smart BatteryProtect 65A/100A/220A	75
Cyrix-ct 12/24V 120A and 230A	76
Cyrix-ct 400A 12/24V and 24/48V	78
SmartShunt 500A / 1000A / 2000A	80
BMV-712 Smart: Bluetooth inside	82
BMV-700 series: precision battery monitoring	84
Argo diode battery isolators	86
Argo FET battery isolators	87
Battery Balancer	88
GEL and AGM batteries	90
12,8 Volt Lithium Iron Phosphate Batteries Smart	94
12,8V & 25,6 Lithium SuperPack batteries	96
Telecom batteries	98
BlueSolar and SmartSolar charge controllers - overview	99
MultiPlus principle	100

Phoenix Inverters Smart 1600VA - 5000VA

[Application Examples](#)

[Motorhomes](#)

[Ambulances](#)

[Coffee cart Espresso](#)

[Systems](#)

[Accessories](#)

[Tools](#)

[Technical information](#)



Phoenix Inverter Smart 12/3000



Bluetooth built-in: fully configurable with a tablet or smartphone

- Low battery voltage alarm
- Low battery voltage cut-off and restart levels
- Dynamic cut-off: load dependent cut-off level
- Output voltage: 210 - 245V
- Frequency: 50 Hz or 60 Hz
- ECO mode on/off and ECO mode sense level
- Alarm relay

Monitoring:

- In- and output voltage, load and alarms

VE.Direct communication port

The VE.Direct port can be connected to a computer (VE.Direct to USB interface cable needed) to configure and monitor the same parameters.

Proven reliability

The full bridge plus toroidal transformer topology has proven its reliability over many years. The inverters are short circuit proof and protected against overheating, whether due to overload or high ambient temperature.

High start-up power

Needed to start loads such as power converters for LED lamps, halogen lamps or electric tools.

ECO mode

When in ECO mode, the inverter will switch to standby when the load decreases below a preset value. Once in standby the inverter will switch on for a short period every 2,5 seconds (adjustable).

If the load exceeds the preset level, the inverter will remain on.

Remote on/off

A remote on/off switch or relay contact can be connected to a two pole connector. Alternatively, the H terminal (left) of the two pole connector can be switched to battery plus, or the L terminal (right) of the two pole connector can be switched to battery minus (or the chassis of a vehicle, for example).

LED diagnosis

Please see manual for a description.

To transfer the load to another AC source: the automatic transfer switch

For our low power inverters we recommend our Filax Automatic Transfer Switch. The Filax features a very short switchover time (less than 20 milliseconds) so that computers and other electronic equipment will continue to operate without disruption. Alternatively use a MultiPlus with built-in transfer switch.

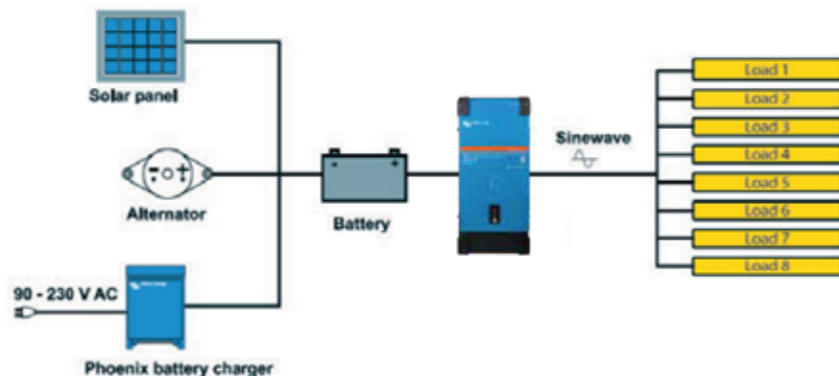

Phoenix Inverter Smart	12/1600 24/1600 48/1600	12/2000 24/2000 48/2000	12/3000 24/3000 48/3000	24/5000 48/5000
Parallel and 3-phase operation	No			
INVERTER				
Input voltage range	9.3 - 17V 18.6 - 34V 37.2 - 68V			
Output	Output voltage: 230 VAC ±2% 50 Hz or 60 Hz ± 0.1% (1)			
Cont. output power at 25°C (1)	1600 VA	2000 VA	3000 VA	5000 VA
Cont. output power at 25°C	1300 W	1600 W	2400 W	4000 W
Cont. output power at 40°C	1200 W	1450 W	2200 W	3700 W
Cont. output power at 65°C	800 W	1000 W	1700 W	2800 W
Peak power	3000 W	4000 W	6000 W	10000 W
Dynamic (load dependent) DC low shut down (fully configurable)	Dynamic cut-off, see https://www.victronenergy.com/docs/ve.direct/Phoenix%20inverters-dynamic-cutoff/			
Max. efficiency 12/ 24 /48 V	92 / 94 / 94%	92 / 94 / 94%	93 / 94 / 95%	95 / 96%
Zero load power 12 / 24 / 48 V	8 / 9 / 11 W	8 / 9 / 11 W	12 / 13 / 15 W	18 / 20 W
Zero load power in ECO mode	0.6 / 1.3 / 2.1 W	0.6 / 1.3 / 2.1 W	1.5 / 1.9 / 2.8 W	2.2 / 3.2 W
GENERAL				
Programmable relay (2)	Yes			
Stop & start power ECO-mode	adjustable			
Protection (3)	a - g			
Bluetooth wireless communication	For remote monitoring and system integration			
VE.Direct communication port	For remote monitoring and system integration			
Remote on-off	Yes			
Common Characteristics	Operating temperature range: -40 to +65°C (fan assisted cooling) Humidity (non-condensing): max 95%			
ENCLOSURE				
Common Characteristics	Material & Colour: steel (blue RAL 5012; and black RAL 9017) Protection category: IP21			
Battery-connection	M8 bolts	M8 bolts	12 V/24 V: 2+2 M8 bolts 48 V: M8 bolts	24 V: 2+2 M8 bolts 48 V: M8 bolts
230 V AC-connection	Screw terminals			
Weight	12kg	13kg	19kg	29kg / 28kg
Dimensions (hxxwxd)	485 x 219 x 125mm	485 x 219 x 125mm	533 x 285 x 150mm (12 V) 485 x 285 x 150mm (24 V/48 V)	595 x 295 x 160mm (24 V) 555 x 295 x 160mm (48 V)
STANDARDS				
Safety	EN 60335-1			
Emission Immunity	EN 55014-1 / EN 55014-2 / EN-IEC 61000-6-1 / EN-IEC 61000-6-2 / EN-IEC 61000-6-3			
Automotive Directive	ECE R10-5			
1) Non-linear load, crest factor 3:1 2) Programmable relay that can a.o. be set for general alarm, DC under voltage or genset start/stop function. AC rating: 230 V / 4 A DC rating: 4 A / 35 VDC, 1A / 60VDC 3) Protection key: a) output short circuit b) overload c) battery voltage too high d) battery voltage too low e) temperature too high f) 230 V AC on inverter output g) input voltage ripple too high				



Phoenix Inverter Control
This panel is intended for remote on/off control of all Phoenix inverters Smart



Color Control GX and other GX devices
Provides monitoring and control. Locally, and remotely on the VRM Portal.



VE.Direct to USB interface
Connects to a USB port.



Bluetooth wireless communication
Connects to a smart phone (both iOS and Android).



BMV-712 Smart Battery Monitor
The BMV Battery Monitor features an advanced microprocessor control system combined with high resolution measuring systems for battery voltage and charge/discharge current. Besides this, the software includes complex calculation algorithms, like Peukert's formula, to exactly determine the state of charge of the battery. The BMV selectively displays battery voltage, current, consumed Ah or time to go. The monitor also stores a host of data regarding performance and use of the battery.

Phoenix Inverters 250VA - 1200VA VE.Direct

- Application Examples
- Motorhomes
- Ambulances
- Coffee cart Espresso Systems
- Accessories
- Tools
- Technical information



Phoenix 12/375 VE.Direct



Phoenix 12/375 VE.Direct



VE.Direct communication port

The VE.Direct port can be connected to:

- A computer (VE.Direct to USB interface cable needed)
- Apple and Android smartphones, tablets, MacBook's and other devices (VE.Direct Bluetooth Smart dongle needed)

Fully configurable:

- Low battery voltage alarm trip and reset levels
- Low battery voltage cut-off and restart levels
- Dynamic cut-off: load dependent cut-off level
- Output voltage 210 - 245V
- Frequency 50 Hz or 60 Hz
- ECO mode on/off and ECO mode sense level

Monitoring:

- In- and output voltage, % load and alarms

Proven reliability

The full bridge plus toroidal transformer topology has proven its reliability over many years. The inverters are short circuit proof and protected against overheating, whether due to overload or high ambient temperature.

High start-up power

Needed to start loads such as power converters for LED lamps, halogen lamps or electric tools.

ECO mode

When in ECO mode, the inverter will switch to standby when the load decreases below a preset value (min load: 15W). Once in standby the inverter will switch on for a short period (adjustable, default: every 2,5 seconds). If the load exceeds a preset level, the inverter will remain on.

Remote on/off

A remote on/off switch can be connected to a two-pole connector, or between battery plus and the left-hand contact of the two-pole connector.

LED diagnosis

Please see manual for a description.

To transfer the load to another AC source: the automatic transfer switch

For our low power inverters, we recommend our Filax Automatic Transfer Switch. The Filax features a very short switchover time (less than 20 milliseconds) so that computers and other electronic equipment will continue to operate without disruption.

Available with different output sockets

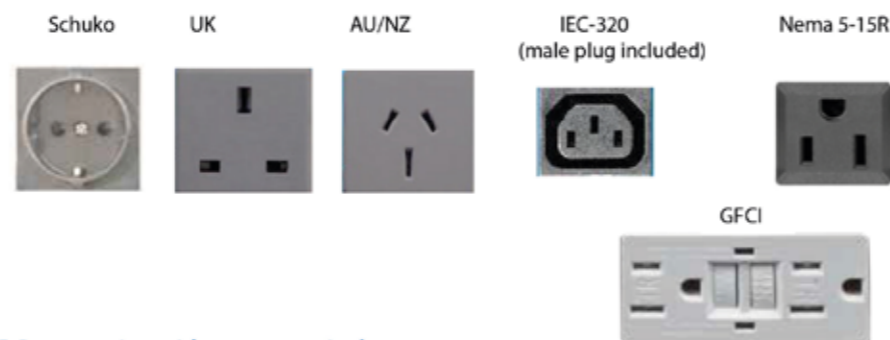

DC connection with screw terminals

No special tools needed for installation

Phoenix Inverter	12 Volt 24 Volt 48 Volt	12/250 24/250 48/250	12/375 24/375 48/375	12/500 24/500 48/500	12/800 24/800 48/800	12/1200 24/1200 48/1200
Cont. power at 25°C (1)		250VA	375VA	500VA	800VA	1200VA
Cont. power at 25°C / 40°C		200 / 175W	300 / 260W	400 / 350W	650 / 560W	1000 / 850W
Peak power		400W	700W	900W	1500W	2200W
Output AC voltage / frequency (adjustable)		230VAC or 120VAC +/- 3% 50Hz or 60Hz +/- 0.1%				
Input voltage range		9,2 - 17 / 18,4 - 34,0 / 36,8 - 62,0V				
DC low shut down (adjustable)		9,3 / 18,6 / 37,2V				
Dynamic (load dependent) DC low shut down (fully configurable)		Dynamic cut-off, see https://www.victronenergy.com/live/ve.direct/phenix-inverters-dynamic-cut-off				
DC low restart and alarm (adjustable)		10,9 / 21,8 / 43,6V				
Battery charged detect (adjustable)		14,0 / 28,0 / 56,0V				
Max. efficiency		87 / 88 / 88%	89 / 89 / 90%	90 / 90 / 91%	90 / 90 / 91%	91 / 91 / 92%
Zero-load power		4,2 / 5,2 / 7,9W	5,6 / 6,1 / 8,5W	6 / 6,5 / 9W	6,5 / 7 / 9,5W	7 / 8 / 10W
Default zero-load power in ECO mode (default retry interval: 2,5 s, adjustable)		0,8 / 1,3 / 2,5W	0,9 / 1,4 / 2,6W	1 / 1,5 / 3,0W	1 / 1,5 / 3,0W	1 / 1,5 / 3,0W
ECO mode stop and start power setting		Adjustable				
Protection (2)		a - f				
Operating temperature range		-40 to +65°C (fan assisted cooling) Derate 1,25% per °C above 40°C				
Humidity (non-condensing)		max 95%				
ENCLOSURE						
Material & Colour		Steel chassis and plastic cover (blue Ral 5012)				
Battery-connection		Screw terminals				
Maximum cable cross-section		10mm ² / AWG8	10mm ² / AWG8	10mm ² / AWG8	25 / 10 / 10mm ² / AWG4 / 8 / 8	35 / 25 / 25mm ² / AWG2 / 4 / 4
Standard AC outlets		230V: Schuko (CEE 7/4), IEC-320 (male plug included) UK (BS 1363), AU/NZ (AS/NZS 3112) 120V: Nema 5-15R, GFCI				
Protection category		IP 21				
Weight		2,4kg / 5,3lbs	3,0kg / 6,6lbs	3,9kg / 8,5lbs	5,5kg / 12lbs	7,4kg / 16,3lbs
Dimensions (h x w x d, mm) (h x w x d, inch)		86 x 165 x 260 3,4 x 6,5 x 10,2	86 x 165 x 260 3,4 x 6,5 x 10,2	86 x 172 x 275 3,4 x 6,8 x 10,8	105 x 216 x 305 4,1 x 8,5 x 12,1 (12V model: 105 x 230 x 325)	117 x 232 x 327 4,6 x 9,1 x 12,9 (12V model: 117 x 232 x 362)
ACCESSORIES						
Remote on-off		Yes				
Automatic transfer switch		Filax				
STANDARDS						
Safety		EN-IEC 60335-1 / EN-IEC 62109-1				
EMC		EN 55014-1 / EN 55014-2 / IEC 61000-6-1 / IEC 61000-6-2 / IEC 61000-6-3				
Automotive Directive		ECE R10-4				



Battery Alarm
An excessively high or low battery voltage is indicated by an audible and visual alarm, and a relay for remote signalling.



BMV Battery Monitor
The BMV Battery Monitor features an advanced microprocessor control system combined with high resolution measuring systems for battery voltage and charge/discharge current. Besides this, the software includes complex calculation algorithms to exactly determine the state of charge of the battery. The BMV selectively displays battery voltage, current, consumed Ah or time to go. The monitor also stores a host of data regarding performance and use of the battery.



VE.Direct Bluetooth Smart dongle (must be ordered separately)

Phoenix Inverters 1200VA - 5000VA 230V

- [Application Examples](#)
- [Motorhomes](#)
- [Ambulances](#)
- [Coffee cart Espresso Systems](#)
- [Accessories](#)
- [Tools](#)
- [Technical information](#)



Phoenix Inverter 24/5000

SinusMax - Superior engineering

Developed for professional duty, the Phoenix range of inverters is suitable for the widest range of applications. The design criteria have been to produce a true sine wave inverter with optimized efficiency but without compromise in performance. Employing hybrid HF technology, the result is a top quality product with compact dimensions, light in weight and capable of supplying power, problem-free, to any load.

Extra start-up power

A unique feature of the SinusMax technology is very high start-up power. Conventional high frequency technology does not offer such extreme performance. Phoenix Inverters, however, are well suited to power up difficult loads such as refrigeration compressors, electric motors and similar appliances.

Virtually unlimited power thanks to parallel and 3-phase operation capability

Up to 6 units inverters can operate in parallel to achieve higher power output. Six 24/5000 units, for example, will provide 24kW / 30kVA output power. Operation in 3-phase configuration is also possible.

To transfer the load to another AC source: the automatic transfer switch

If an automatic transfer switch is required we recommend using the MultiPlus inverter/charger instead. The switch is included in these products and the charger function of the MultiPlus can be disabled. Computers and other electronic equipment will continue to operate without disruption because the MultiPlus features a very short switchover time (less than 20 milliseconds).

Communications interface

These larger Phoenix inverter models come with a VE.Bus port. All you need to connect to your PC is our MK3-USB VE.Bus to USB interface (see under accessories). Together with our VictronConnect or VEConfigure software, which can be downloaded free of charge from our website, parameters of the inverters can be customized. This includes output voltage and frequency, over and under voltage settings and programming the relay. This relay can for example be used to signal several alarm conditions, or to start a generator. The inverters can also be connected to a GX device (eg Cerbo GX) for monitoring and control.

New applications of high power inverters

The possibilities of paralleled high power inverters are truly amazing. For ideas, examples and battery capacity calculations please refer to our book 'Energy Unlimited' (available free of charge from Victron Energy and downloadable from www.victronenergy.com).



Phoenix Inverter Compact 24/1600

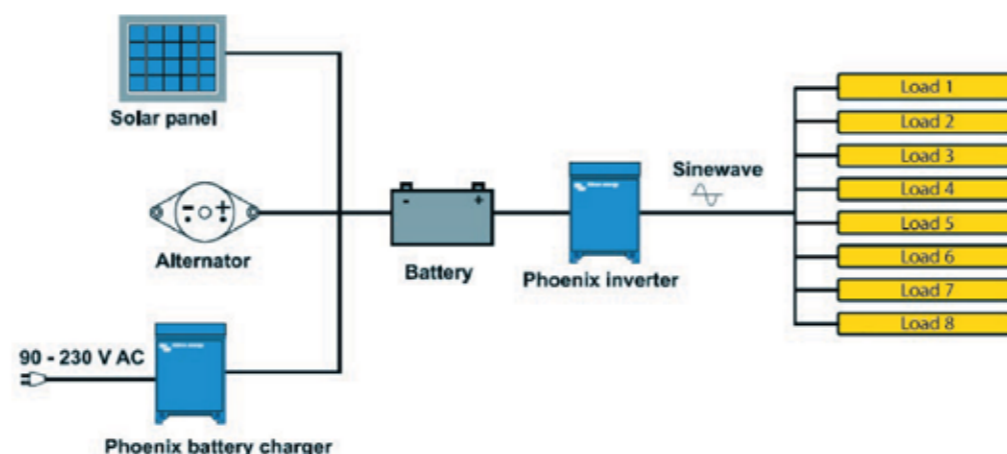

Phoenix Inverter	C12/1200 C24/1200	C12/1600 C24/1600	C12/2000 C24/2000	12/3000 24/3000 48/3000	24/5000 48/5000
Parallel and 3-phase operation	Yes				
INVERTER					
Input voltage range (V DC)	9.5 - 17V 19 - 33V 38 - 66V				
Output	Output voltage: 230 VAC ± 2% Frequency: 50 Hz ± 0.1% (1)				
Cont. output power at 25°C (VA) (2)	1200	1600	2000	3000	5000
Cont. output power at 25°C (W)	1000	1300	1600	2400	4000
Cont. output power at 40°C (W)	900	1200	1450	2200	3700
Cont. output power at 65°C (W)	600	800	1000	1700	3000
Peak power (W)	2400	3000	4000	6000	10000
Max. efficiency 12/24 / 48V (%)	92 / 94 / 94	92 / 94 / 94	92 / 92	93 / 94 / 95	94 / 95
Zero load power 12 / 24 / 48V (W)	8 / 10 / 12	8 / 10 / 12	9 / 11	20 / 20 / 25	30 / 35
Zero load power in AES mode (W)	5 / 8 / 10	5 / 8 / 10	7 / 9	15 / 15 / 20	25 / 30
Zero load power in Search mode (W)	2 / 3 / 4	2 / 3 / 4	3 / 4	8 / 10 / 12	10 / 15
GENERAL					
Programmable relay (3)	Yes				
Protection (4)	a - g				
VE.Bus communication port	For parallel and three phase operation, remote monitoring and system integration				
Remote on-off	Yes				
Common Characteristics	Operating temperature range: -40 to +65°C (fan assisted cooling) Humidity (non-condensing): max 95%				
ENCLOSURE					
Common Characteristics	Material & Colour: aluminium (blue RAL 5012) Protection category: IP21				
Battery-connection	battery cables of 1.5 meter included		M8 bolts	2+2 M8 bolts	
230 V AC-connection	G-ST18; plug		Spring-clamp	Screw terminals	
Weight (kg)	10		12	18	30
Dimensions (hwxhxd in mm)	375 x 214 x 110		520 x 255 x 125	362 x 258 x 218	444 x 328 x 240
STANDARDS					
Safety	EN 60335-1				
Emission immunity	EN 55014-1 / EN 55014-2				

1) Can be adjusted to 60 Hz and to 240 V
2) Non-linear load, crest factor 3:1
3) Programmable relay that can a.o. be set for general alarm, DC under voltage or genset start/stop function.
AC rating: 230 V / 4 A
DC rating: 4 A up to 35 VDC, 1 A up to 60VDC

A) Protection key:
a) output short circuit
b) overload
c) battery voltage too high
d) battery voltage too low
e) temperature too high
f) 230 V AC on inverter output
g) input voltage ripple too high



Phoenix Inverter Control
This panel can also be used on a MultiPlus Inverter/Charger when an automatic transfer switch but no charger function is desired. The brightness of the LEDs is automatically reduced during night time.

Computer controlled operation and monitoring

Several interfaces are available:



Color Control GX
Provides monitor and control. Locally, and also remotely on the [VRM Portal](#).



MK3-USB VE.Bus to USB interface
Connects to a USB port (see: [A guide to VEConfigure?](#))



VE.Bus to NMEA 2000 interface
Connects the device to a NMEA 2000 marine electronics network. See the [NMEA 2000 & MED integration guide](#)



BMV-700 Battery Monitor
The BMV-700 Battery Monitor features an advanced microprocessor control system combined with high resolution measuring systems for battery voltage and charge/discharge current. Besides this, the software includes complex calculation algorithms, like Peukert's formula, to exactly determine the state of charge of the battery. The BMV-700 selectively displays battery voltage, current, consumed Ah or time to go. The monitor also stores a host of data regarding performance and use of the battery.

Several models available (see battery monitor documentation).

MultiPlus Inverter/charger 500VA - 1600VA

Proven reliability

The full bridge plus toroidal transformer topology has proven its reliability over many years. The inverter is short circuit proof and protected against overheating, whether due to overload or high ambient temperature.

PowerControl - Dealing with limited generator, shore side or grid power

With the Multi Control Panel a maximum generator or shore current can be set. The MultiPlus will then take account of other AC loads and use whatever is extra for charging, thus preventing the generator or shore supply from being overloaded.

PowerAssist - Boosting the capacity of shore or generator power

Where peak power is so often required only for a limited period, the MultiPlus will make sure that insufficient shore or generator power is immediately compensated for by power from the battery. When the load reduces, the spare power is used to recharge the battery.

High start-up power

Needed to start high inrush loads such as power converters for LED lamps, halogen lamps or electric tools.

Search Mode

When Search Mode is 'on', the power consumption of the inverter in no-load operation is decreased by approx. 70%. In this mode the Multi, when operating in inverter mode, is switched off in case of no load or very low load, and switches on every two seconds for a short period. If the output current exceeds a set level, the inverter will continue to operate. If not, the inverter will shut down again.

Programmable relay

By default, the programmable relay is set as an alarm relay, i.e. the relay will de-energise in the event of an alarm or a pre-alarm (inverter almost too hot, ripple on the input almost too high, battery voltage almost too low).



12 Volt	12/500/20	12/800/35	12/1200/50	12/1600/70
24 Volt	24/500/10	24/800/16	24/1200/25	24/1600/40
48 Volt	48/500/6	48/800/9	48/1200/13	48/1600/20
PowerControl / PowerAssist	Yes / No		Yes / Yes	
Three Phase and parallel operation	Yes			
Transfer switch	16A			
INVERTER				
Input voltage range	9,5 - 17V		19 - 33V	38 - 66V
Output	Output voltage: 230VAC ± 2%		Frequency: 50Hz ± 0,1% (1)	
Cont. output power at 25°C (3)	500VA	800VA	1200VA	1600VA
Cont. output power at 25°C	430W	700W	1000W	1300W
Cont. output power at 40°C	400W	650W	900W	1100W
Cont. output power at 65°C	300W	400W	600W	800W
Peak power	900W	1600W	2400W	2800W
Maximum efficiency	90 / 91 / 92%	92 / 93 / 94%	93 / 94 / 95%	93 / 94 / 95%
Zero-load power	6 / 6 / 7W	7 / 7 / 8W	10 / 9 / 10W	10 / 9 / 10W
Zero-load power in search mode	2 / 2 / 3W	2 / 2 / 3W	3 / 3 / 3W	3 / 3 / 3W
CHARGER				
AC Input	Input voltage range: 187-265 VAC		Input frequency: 45 - 65 Hz	
Charge voltage 'absorption'	14,4 / 28,8 / 57,6V			
Charge voltage 'float'	13,8 / 27,6 / 55,2V			
Storage mode	13,2 / 26,4 / 52,8V			
Charge current house battery (4)	20 / 10 / 6A	35 / 16 / 9A	50 / 25 / 13A	70 / 40 / 20A
Charge current starter battery	1A (12V and 24V models only)			
Battery temperature sensor	Yes			
GENERAL				
Programmable relay (5)	Yes			
Protection (2)	a - g			
VE.Bus communication port	For parallel and three phase operation, remote monitoring and system integration (RJ45-splitter ASS030065510 needed for 500/800/1200VA models)			
Remote on-off	On/off/charger only		On/off	
DIP switches	Yes (6)		Yes (7)	
Internal DC fuse	125/60/30A	150/80/40A	200/100/50A	200/125/60A
Common Characteristics	Operating temp. range: -40 to +65°C (fan assisted cooling) Humidity (non-condensing): max 95%			
ENCLOSURE				
Common Characteristics	Material & Colour: Steel/ABS (blue RAL 5012)		Protection category: IP 21	
Battery-connection	16 / 10 / 10 mm ²	25 / 16 / 10 mm ²	35 / 25 / 10 mm ²	50 / 35 / 16 mm ²
230V AC-connection	G-ST18i connector			
Weight	4,4 kg	6,4 kg	8,2 kg	10,2 kg
Dimensions (h x w x d)	311 x 182 x 100 mm	360 x 240 x 100 mm	406 x 250 x 100 mm	470 x 265 x 120 mm
STANDARDS				
Safety	EN-IEC 60335-1, EN-IEC 60335-2-29, EN 62109-1			
Emission / Immunity	EN 55014-1, EN 55014-2, EN-IEC 61000-3-2, EN-IEC 61000-3-3 IEC 61000-6-1, IEC 61000-6-2, IEC 61000-6-3			
Road vehicles	ECE R10-5			
<p>1) Can be adjusted to 60Hz and to 240V 2) Protection a. Output short circuit b. Overload c. Battery voltage too high d. Battery voltage too low e. Temperature too high f. 230VAC on inverter output g. Input voltage ripple too high</p> <p>3) Non-linear load, crest factor 3:1 4) At 25 °C ambient 5) Programmable relay which can be set for: general alarm, DC under voltage or generator start/stop signal function AC rating: 230V/4A DC rating: 4A up to 35VDC, 1A up to 60VDC 6) Remote / Battery charge voltage / Inverter frequency / search mode 7) Battery charge voltage / search mode</p>				



MultiPlus inverter/charger 800VA - 5kVA 230V

Lithium Ion battery compatible

[Application Examples](#)

[Motorhomes](#)

[Ambulances](#)

[Coffee cart Espresso](#)

[Systems](#)

[Accessories](#)

[Tools](#)

[Technical information](#)



MultiPlus
24/3000/70



MultiPlus Compact
12/2000/80

Two AC Outputs

The main output has no break functionality. The MultiPlus takes over the supply to the connected loads in the event of a grid failure or when shore/generator power is disconnected. This happens so fast (less than 20 milliseconds) that computers and other electronic equipment will continue to operate without disruption. The second output is live only when AC is available on the input of the MultiPlus. Loads that should not discharge the battery, like a water heater for example can be connected to this output (second output available on models rated at 3 kVA and more).

Virtually unlimited power thanks to parallel operation

Up to 6 Multis can operate in parallel to achieve higher power output. Six 24/5000/120 units, for example, will provide 25 kW / 30 kVA output power with 720 Amps charging capacity.

Three phase capability

In addition to parallel connection, three units of the same model can be configured for three phase output. But that's not all: up to 6 sets of three units can be parallel connected for a 75 kW / 90 kVA inverter and more than 2000 Amps charging capacity.

PowerControl - Dealing with limited generator, shore side or grid power

The MultiPlus is a very powerful battery charger. It will therefore draw a lot of current from the generator or shore side supply (nearly 10 A per 5 kVA Multi at 230 VAC). With the Multi Control Panel a maximum generator or shore current can be set. The MultiPlus will then take account of other AC loads and use whatever is extra for charging, thus preventing the generator or shore supply from being overloaded.

PowerAssist - Boosting the capacity of shore or generator power

This feature takes the principle of PowerControl to a further dimension. It allows the MultiPlus to supplement the capacity of the alternative source. Where peak power is so often required only for a limited period, the MultiPlus will make sure that insufficient shore or generator power is immediately compensated for by power from the battery. When the load reduces, the spare power is used to recharge the battery.

Solar energy: AC power available even during a grid failure

The MultiPlus can be used in off grid as well as grid connected PV and other alternative energy systems. Loss of mains detection software is available.

System configuring

- In case of a stand-alone application, if settings have to be changed, this can be done in a matter of minutes with a DIP switch setting procedure.
- Parallel and three phase applications can be configured with VE.Bus Quick Configure and VE.Bus System Configurator software.
- Off grid, grid interactive and self-consumption applications, involving grid-tie inverters and/or MPPT Solar Chargers can be configured with Assistants (dedicated software for specific applications).

On-site Monitoring and control

Several options are available: Battery Monitor, Multi Control Panel, Color Control GX or other GX devices, smartphone or tablet (Bluetooth Smart), laptop or computer (USB or RS232).

Remote Monitoring and control

Color Control GX or other GX devices.

Data can be stored and displayed on our VRM (Victron Remote Management) website, free of charge.

Remote configuring

When connected to the Ethernet, systems with a Color Control GX or other GX device can be accessed and settings can be changed remotely.



Color Control GX, showing a PV application

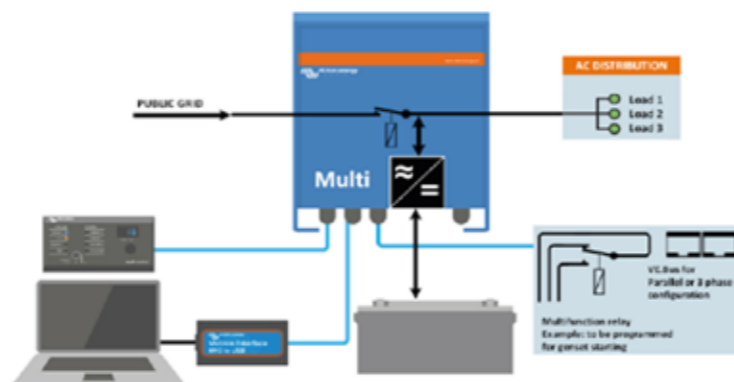

MultiPlus	12 Volt 24 Volt 48 Volt	C 12/800/35 C 24/800/16	C 12/1200/50 C 24/1200/25	C 12/1600/70 C 24/1600/40	C 12/2000/80 C 24/2000/50	12/3000/120 24/3000/70 48/3000/35	24/5000/120 48/5000/70
PowerControl		Yes	Yes	Yes	Yes	Yes	Yes
PowerAssist		Yes	Yes	Yes	Yes	Yes	Yes
Transfer switch (A)		16	16	16	30	16 or 50	100
INVERTER							
Input voltage range (V DC)		9,5 - 17 V		19 - 33 V	38 - 66 V		
Output		Output voltage: 230 VAC ± 2%		Frequency: 50 Hz ± 0.1% (1)			
Cont. output power at 25°C (VA) (3)		800	1200	1600	2000	3000	5000
Cont. output power at 25°C (W)		700	1000	1300	1600	2400	4000
Cont. output power at 40°C (W)		650	900	1200	1400	2200	3700
Cont. output power at 65°C (W)		400	600	800	1000	1700	3000
Peak power (W)		1600	2400	3000	4000	6000	10000
Maximum efficiency (%)		92 / 94	93 / 94	93 / 94	93 / 94	93 / 94 / 95	94 / 95
Zero load power (W)		8 / 10	8 / 10	8 / 10	9 / 11	20 / 20 / 25	30 / 35
Zero load power in AGS mode (W)		5 / 8	5 / 8	5 / 8	7 / 9	15 / 15 / 20	25 / 30
Zero load power in Search mode (W)		2 / 3	2 / 3	2 / 3	3 / 4	8 / 10 / 12	10 / 15
CHARGER							
AC input		Input voltage range: 187-265 VAC		Input frequency: 45 - 65 Hz		Power factor: 1	
Charge voltage 'absorption' (V DC)				14,4 / 28,8 / 57,6			
Charge voltage 'float' (V DC)				13,8 / 27,6 / 55,2			
Storage mode (V DC)				13,2 / 26,4 / 52,8			
Charge current house battery (A) (4)		35 / 16	50 / 25	70 / 40	80 / 50	120 / 70 / 35	120 / 70
Charge current starter battery (A)		4 (12 V and 24 V models only)					
Battery temperature sensor		yes					
GENERAL							
Auxiliary output (5)		n. a.	n. a.	n. a.	n. a.	Yes (16A)	Yes (50A)
Programmable relay (6)		Yes					
Protection (2)		a - g					
VE.Bus communication port		For parallel and three phase operation, remote monitoring and system integration					
General purpose com. port		n. a.	n. a.	n. a.	n. a.	Yes	Yes
Remote on-off		Yes					
Common Characteristics		Operating temp. range: -40 to +65°C (fan assisted cooling) Humidity (non-condensing): max 95%					
ENCLOSURE							
Common Characteristics		Material & Colour: aluminium (blue RAL 5012)		Protection category: IP 21			
Battery-connection		battery cables of 1.5 meter		M8 bolts	Four M8 bolts (2 plus and 2 minus connections)		
230 V AC-connection		G-ST181 connector		Spring-clamp	Screw terminals 13 mm ² (6 AWG)		M6 bolts
Weight (kg)		10	10	10	12	18	30
Dimensions (hwxwxd in mm)		375 x 214 x 110		520 x 255 x 125		362 x 258 x 218 444 x 328 x 240	
STANDARDS							
Safety		EN-IEC 60335-1, EN-IEC 60335-2-29, IEC 62109-1					
Emission, Immunity		EN 55014-1, EN 55014-2, EN-IEC 61000-3-2, EN-IEC 61000-3-3, IEC 61000-6-1, IEC 61000-6-2, IEC 61000-6-3					
Road vehicles		12V and 24V models: ECE R10-4					
Anti-islanding		See our website					
<p>1) Can be adjusted to 60 Hz. 120 V models available on request</p> <p>2) Protection key: a) output short circuit b) overload c) battery voltage too high d) battery voltage too low e) temperature too high f) 230 VAC on inverter output g) input voltage ripple too high</p> <p>3) Non-linear load, crest factor 3:1 4) At 25°C ambient 5) Switches off when no external AC source available 6) Programmable relay that can a.o. be set for general alarm, DC under voltage or genset start/stop function AC rating: 230 V/4A DC rating: 4 A up to 35 VDC, 1 A up to 60 VDC</p>							



Digital Multi Control Panel

A convenient and low cost solution for remote monitoring, with a rotary knob to set PowerControl and PowerAssist levels.



VE.Bus Smart Dongle

Measures battery voltage and temperature and allows monitoring and control of Multis and Quattros with a smartphone or other Bluetooth enabled device.



Computer controlled operation and monitoring

Several interfaces are available:



Color Control GX and other GX devices

Monitoring and control. Locally, and also remotely on the VRM Portal.



MK3-USB (VE.Bus to USB interface)

Connects to a USB port (see 'A guide to VE.Configure')



VE.Bus to NMEA 2000 interface

Connects the device to a NMEA2000 marine electronics network. See the NMEA2000 & MFD integration guide.



BMV-712 Smart Battery Monitor

Use a smartphone or other Bluetooth enabled device to:

- customize settings,
- monitor all important data on single screen,
- view historical data, and to
- update the software when new features become available.

MultiPlus inverter/charger 2kVA and 3kVA 120V

[Application Examples](#)

[Motorhomes](#)

[Ambulances](#)

[Coffee cart Espresso](#)

[Systems](#)

[Accessories](#)

[Tools](#)

[Technical information](#)



MultiPlus
24/3000/70



MultiPlus Compact
12/2000/80

Multifunctional, with intelligent power management

The MultiPlus is a powerful true sine wave inverter, a sophisticated battery charger that features adaptive charge technology, and a high-speed AC transfer switch in a single compact enclosure. Next to these primary functions, the MultiPlus has several advanced features, as outlined below.

Two AC Outputs

The main output has no-break functionality. The MultiPlus takes over the supply to the connected loads in the event of a grid failure or when shore-/generator power is disconnected. This happens so fast (less than 20 milliseconds) that computers and other electronic equipment will continue to operate without disruption.

The second output is live only when AC is available on the input of the MultiPlus. Loads that should not discharge the battery, like a water heater for example, can be connected to this output (second output available on models rated at 3kVA and more).

Virtually unlimited power thanks to parallel operation

Up to six Multis can operate in parallel to achieve higher power output. Six 24/3000/70 units, for example, provide 18kW / 18kVA output power with 420 Amps of charging capacity.

Three phase capability

In addition to parallel connection, three units can be configured for three-phase output. But that's not all: with three strings of six parallel units a 45 kW / 54 kVA three phase inverter and 1260 A charger can be built.

Split phase options

Two units can be stacked to provide 120-0-120 V, and additional units can be paralleled up to a total of 6 units per phase, to supply up to 30 kW / 36 kVA of split phase power.

Alternatively, a split phase AC source can be obtained by connecting our autotransformer (see data sheet on www.victronenergy.com) to a 'European' inverter programmed to supply 240 V / 60 Hz.

PowerControl - Dealing with limited generator, shore side or grid power

The MultiPlus is a very powerful battery charger. It will therefore draw a lot of current from the generator or shore side supply (nearly 20 A per 3 kVA MultiPlus at 120 VAC). With the Multi Control Panel a maximum generator or shore current can be set. The MultiPlus will then take account of other AC loads and use whatever is extra for charging, thus preventing the generator or shore supply from being overloaded.

PowerAssist - Boosting the capacity of shore or generator power

This feature takes the principle of PowerControl to a further dimension. It allows the MultiPlus to supplement the capacity of the alternative source. Where peak power is so often required only for a limited period, the MultiPlus will make sure that insufficient shore or generator power is immediately compensated for by power from the battery. When the load reduces, the spare power is used to recharge the battery.

Four stage adaptive charger and dual bank battery charging

The main output provides a powerful charge to the battery system by means of advanced 'adaptive charge' software. The software fine-tunes the three stage automatic process to suit the condition of the battery, and adds a fourth stage for long periods of float charging. The adaptive charge process is described in more detail on the Phoenix Charger datasheet and on our website, under Technical Information. In addition to this, the MultiPlus will charge a second battery using an independent trickle charge output intended for a main engine or generator starter battery.

System configuring has never been easier

After installation, the MultiPlus is ready to go. If settings have to be changed, this can be done in a matter of minutes with a DIP switch setting procedure. Even parallel and 3-phase operation can be programmed with DIP switches: no computer needed! Alternatively, VE.Net can be used instead of the DIP switches. And sophisticated software (VE.Bus Quick Configure and VE.Bus System Configurator) is available to configure several new, advanced, features.

PowerAssist with 2x MultiPlus in parallel

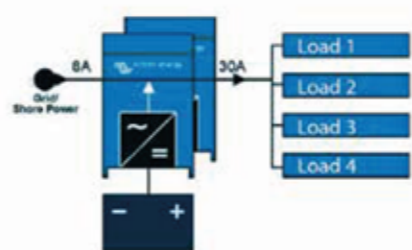

Five parallel units: output power 12,5 kW

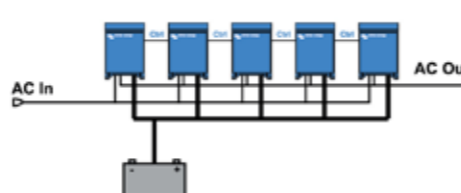

MultiPlus	12 Volt 24 Volt	12/2000/80 24/2000/50	12/3000/120 24/3000/70
PowerControl			Yes
PowerAssist			Yes
Transfer switch (A)		50	
Parallel and 3-phase operation			Yes
INVERTER			
Input voltage range (V DC)		9,5 - 17 V	19 - 33 V
Output		Output voltage: 120 VAC ± 2%	Frequency: 60 Hz ± 0,1% (1)
Cont. output power at 25°C / 77°F (VA) (3)		2000	3000
Cont. output power at 25°C / 77°F (W)		1600	2400
Cont. output power at 40°C / 104°F (W)		1450	2200
Cont. output power at 65°C / 150°F (W)		1100	1700
Peak power (W)		4000	6000
Maximum efficiency (%)		92 / 94	93 / 94
Zero load power (W)		9 / 11	20 / 20
Zero load power in AES mode (W)		7 / 8	15 / 15
Zero load power in Search mode (W)		3 / 4	8 / 10
CHARGER			
AC Input		Input voltage range: 95-140 VAC	Input frequency: 45 - 65 Hz Power factor: 1
Charge voltage 'absorption' (V DC)		14,4 / 26,8	
Charge voltage 'float' (V DC)		13,8 / 27,6	
Storage mode (V DC)		13,2 / 26,4	
Charge current house battery (A) (4)		80 / 50	120 / 70
Charge current starter battery (A)		4	
Battery temperature sensor		yes	
GENERAL			
Auxiliary output (5)		n.a.	Yes (32A)
Programmable relay (6)		Yes (1x)	Yes (3x)
Protection (2)			a - g
VE.Bus communication port		For parallel and three phase operation, remote monitoring and system integration	
General purpose com. port (7)		n.a.	Yes (2x)
Remote on-off		Yes	
Common Characteristics		Operating temp. range: -40 - +65°C / -40 to 150°F (fan assisted cooling)	Humidity (non-condensing): max 95%
ENCLOSURE			
Common Characteristics		Material & Colour: aluminium (blue RAL 5012)	Protection category: IP 21
Battery connection		M8 bolts	M8 bolts (2 plus and 2 minus connections)
120 V AC connection		Screw terminal 6 AWG (13 mm ²)	Screw terminal 6 AWG (13 mm ²)
Weight		13 kg / 28 lbs.	19kg / 40 lbs.
Dimensions (h/w/d in mm and inches)		520x255x125 mm / 20.5x10.0x5.0 inch	362x256x128 mm / 14.3x10.2x8.6 inch
STANDARDS			
Safety		EN-IEC 60335-1, EN-IEC 60335-2-29	UL 1741, UL 458, EN-IEC 60335-1, EN-IEC 60335-2-29
Emission and Immunity		EN-IEC 61000-3-2/3-3/, EN-IEC 61000-6-1/6-2/6-3	EN-IEC 61000-3-2/3-3/, EN-IEC 61000-6-1/6-2/6-3
1) Protection key:		1) Non-linear load, crest factor 3:1	
a) output short circuit		2) At 75°F ambient	
b) overload		3) Switches off when no external AC source available	
c) battery voltage too high		4) Switches off when no external AC source available	
d) battery voltage too low		5) Programmable relay that can a.o. be set for general alarm	
e) temperature too high		DC under voltage or genset start/stop function	
f) 230 VAC on inverter output		AC rating: 230 V/4 A	
g) input voltage ripple too high		DC rating: 4 A up to 35 VDC, 1 A up to 60 VDC	
		6) A.o. to communicate with a Lithium Ion battery BMS	



Digital Multi Control

A convenient and low cost solution for remote monitoring, with a rotary knob to set PowerControl and PowerAssist levels.

Computer controlled operation and monitoring

Several interfaces are available:



Color Control GX and other GX devices
Provides monitor and control. Locally, and also remotely on the [VRM Portal](#).



MK3-USB VE.Bus to USB interface
Connects to a USB port (see [A guide to VEConfigure](#))



VE.Bus Smart Dongle
Measures battery voltage and temperature and allows monitoring and control of Multis and Quattros with a smartphone or other Bluetooth enabled device.



VE.Bus to NMEA 2000 interface
Connects the device to a NMEA2000 marine electronics network. See the [NMEA2000 & MFD integration guide](#)



BMV-712 Smart Battery Monitor

Use a smartphone or other Bluetooth enabled device to:

- customize settings,
- monitor all important data on single screen,
- view historical data, and to
- update the software when new features become available.

Quattro Inverter/charger 3kVA - 15kVA 230V

Lithium Ion battery compatible

Two AC Inputs with Integrated transfer switch

The Quattro can be connected to two independent AC sources, for example the public grid and a generator, or two generators. The Quattro will automatically connect to the active source.

Two AC Outputs

The main output has no-break functionality. The Quattro takes over the supply to the connected loads in the event of a grid failure or when shore/generator power is disconnected. This happens so fast (less than 20 milliseconds) that computers and other electronic equipment will continue to operate without disruption. The second output is live only when AC is available on one of the inputs of the Quattro. Loads that should not discharge the battery, like a water heater for example, can be connected to this output.

Virtually unlimited power thanks to parallel operation

Up to 6 Quattro units can operate in parallel. Six units 48/10000/140, for example, will provide 48kW / 60kVA output power and 840 Amps charging capacity.

Split phase options

Two units can be stacked to provide 120-0-120V, and additional units can be paralleled up to a total of 6 units per phase, to supply up to 30kW / 36kVA of split phase power.

Alternatively, a split phase AC source can be obtained by connecting our autotransformer (see data sheet on www.victronenergy.com) to a 'European' inverter programmed to supply 240V / 60Hz.

Three phase capability

Three units can be configured for three phase output. But that's not all: up to 6 sets of three units can be parallel connected to provide 144kW / 180kVA inverter power and more than 2500A charging capacity.

PowerControl – Dealing with limited generator, shore side or grid power

The Quattro is a very powerful battery charger. It will therefore draw a lot of current from the generator or shore side supply (16A per 5kVA Quattro at 230VAC). A current limit can be set on each AC input. The Quattro will then take account of other AC loads and use whatever is spare for charging, thus preventing the generator or mains supply from being overloaded.

PowerAssist – Boosting shore or generator power

This feature takes the principle of PowerControl to a further dimension allowing the Quattro to supplement the capacity of the alternative source. Where peak power is so often required only for a limited period, the Quattro will make sure that insufficient mains or generator power is immediately compensated for by power from the battery. When the load reduces, the spare power is used to recharge the battery.

Solar energy: AC power available even during a grid failure

The Quattro can be used in off grid as well as grid connected PV and other alternative energy systems. Loss of mains detection software is available.

System configuring

- In case of a stand-alone application, if settings have to be changed, this can be done in a matter of minutes with a DIP switch setting procedure.
- Parallel and three phase applications can be configured with VE.Bus Quick Configure and VE.Bus System Configurator software.
- Off grid, grid interactive and self-consumption applications, involving grid-tie inverters and/or MPPT Solar Chargers can be configured with Assistants (dedicated software for specific applications).

On-site Monitoring and control

Several options are available: Battery Monitor, Multi Control Panel, Color Control GX or other GX devices, smartphone or tablet (Bluetooth Smart), laptop or computer (USB or RS232).

Remote Monitoring and control

Color Control GX or other GX devices.

Data can be stored and displayed on our VRM (Victron Remote Management) website, free of charge.

Remote configuring

When connected to the Ethernet, systems with a Color Control GX or other GX device can be accessed and settings can be changed remotely.



Quattro
48/5000/70-100/100



Quattro
48/15000/200-100/100



Color Control GX, showing a PV application

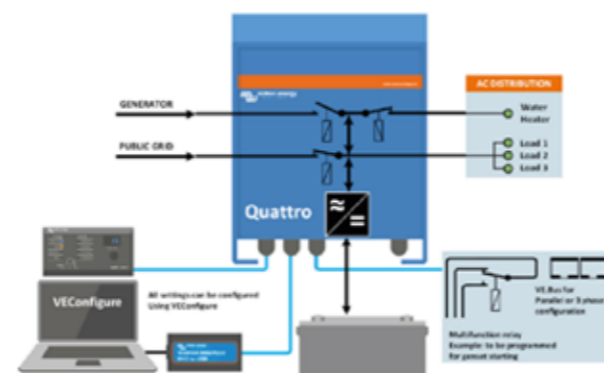

Quattro	12/3000/120-50/50 24/3000/70-50/50	12/5000/220-100/100 24/5000/120-100/100 48/5000/70-100/100	24/8000/200-100/100 48/8000/110-100/100	48/10000/140-100/100	48/15000/200-100/100
PowerControl / PowerAssist	Yes				
Integrated Transfer switch	Yes				
AC inputs (2x)	Input voltage range: 187-265 VAC Input frequency: 45 – 65 Hz Power factor: 1				
Maximum feed through current (A)	2x 50	2x100	2x100	2x100	2x100
INVERTER					
Input voltage range (V DC)	9.5 – 17V 19 – 33V 38 – 66V				
Output (1)	Output voltage: 230 VAC ± 2% Frequency: 50 Hz ± 0.1%				
Cont. output power at 25°C (VA) (3)	3000	5000	8000	10000	15000
Cont. output power at 25°C (W)	2400	4000	6500	8000	12000
Cont. output power at 40°C (W)	2200	3700	5500	6500	10000
Cont. output power at 65°C (W)	1700	3000	3600	4500	7000
Peak power (W)	6000	10000	16000	20000	25000
Maximum efficiency (%)	93 / 94	94 / 94 / 95	94 / 96	96	96
Zero load power (W)	20 / 20	30 / 30 / 35	60 / 60	60	110
Zero load power in AES mode (W)	15 / 15	20 / 25 / 30	40 / 40	40	75
Zero load power in Search mode (W)	8 / 10	10 / 10 / 15	15 / 15	15	20
CHARGER					
Charge voltage 'absorption' (V DC)	14.4 / 28.8	14.4 / 28.8 / 57.6	28.8 / 57.6	57.6	57.6
Charge voltage 'float' (V DC)	13.8 / 27.6	13.8 / 27.6 / 55.2	27.6 / 55.2	55.2	55.2
Storage mode (V DC)	13.2 / 26.4	13.2 / 26.4 / 52.8	26.4 / 52.8	52.8	52.8
Charge current house battery (A) (4)	120 / 70	220 / 120 / 70	200 / 110	140	200
Charge current starter battery (A)	4 (12V and 24V models only)				
Battery temperature sensor	Yes				
GENERAL					
Auxiliary output (A) (5)	25	50	50	50	50
Programmable relay (6)	3x	3x	3x	3x	3x
Protection (2)	a-g				
VE.Bus communication port	For parallel and three phase operation, remote monitoring and system integration				
General purpose com. port	2x	2x	2x	2x	2x
Remote on-off	Yes				
Common Characteristics	Operating temp.: -40 to +65°C Humidity (non-condensing): max. 95%				
ENCLOSURE					
Common Characteristics	Material & Colour: aluminium (blue RAL 5012) Protection category: IP 21				
Battery-connection	Four M8 bolts (2 plus and 2 minus connections)				
230 V AC-connection	Screw terminals 13 mm ² (6 AWG)	Bolts M6	Bolts M6	Bolts M6	Bolts M6
Weight (kg)	19	34 / 30 / 30	45 / 41	51	72
Dimensions (h x w x d in mm)	362 x 258 x 218	470 x 350 x 280 444 x 328 x 240 444 x 328 x 240	470 x 350 x 280	470 x 350 x 280	572 x 488 x 344
STANDARDS					
Safety	EN-IEC 60335-1, EN-IEC 60335-2-29, EN-IEC 62109-1				
Emission, immunity	EN 55014-1, EN 55014-2, EN-IEC 61000-3-2, EN-IEC 61000-3-3, IEC 61000-6-1, IEC 61000-6-2, IEC 61000-6-3				
Road vehicles	12V and 24V models: ECE R10-4				
Anti-islanding	See our website				
1) Can be adjusted to 60 Hz. 120 V models available on request	3) Non-linear load, crest factor 3:1				
2) Protection key:	4) At 25°C ambient				
a) output short circuit	5) Switches off when no external AC source available				
b) overload	6) Programmable relay that can a.o. be set for general alarm, DC under voltage or genset start/stop function				
c) battery voltage too high	AC rating: 230 V / 4 A				
d) battery voltage too low	DC rating: 4 A up to 35 VDC, 1 A up to 60 VDC				
e) temperature too high					
f) 230 VAC on inverter output					
g) input voltage ripple too high					



Digital Multi Control Panel

A convenient and low cost solution for remote monitoring, with a rotary knob to set PowerControl and PowerAssist levels.



VE.Bus Smart Dongle

Measures battery voltage and temperature and allows monitoring and control of Multis and Quattros with a smartphone or other Bluetooth enabled device.

Computer controlled operation and monitoring

Several interfaces are available:



Color Control GX and other GX devices

Monitoring and control. Locally, and also remotely on the VRM Portal.



MK3-USB (VE.Bus to USB interface)

Connects to a USB port (see [A guide to VEConfigure](#))



VE.Bus to NMEA 2000 interface

Connects the device to a NMEA2000 marine electronics network. See the [NMEA2000 & MFD integration guide](#)



BMV-712 Smart Battery Monitor

Use a smartphone or other Bluetooth enabled device to:

- customize settings,
- monitor all important data on single screen,
- view historical data, and to
- update the software when new features become available.

Quattro Inverter/charger 3kVA - 10kVA 120V

Application Examples

Motorhomes

Ambulances

Coffee cart Espresso

Systems

Accessories

Tools

Technical information

Two AC inputs with integrated transfer switch

The Quattro can be connected to two independent AC sources, for example the public grid and a generator, or two generators. The Quattro will automatically connect to the active source.

Two AC Outputs

The main output has no-break functionality. The Quattro takes over the supply to the connected loads in the event of a grid failure or when shore/generator power is disconnected. This happens so fast (less than 20 milliseconds) that computers and other electronic equipment will continue to operate without disruption.

The second output is live only when AC is available on one of the inputs of the Quattro. Loads that should not discharge the battery, like a water heater for example, can be connected to this output.

Virtually unlimited power thanks to parallel operation

Up to 6 Quattro units can operate in parallel. Six units 48/10000/140, for example, will provide 48kW / 60kVA output power and 840 Amps charging capacity.

Split phase and three phase capability

Two units can be configured for split phase, and three units can be configured for three phase output. But that's not all: up to 6 sets of three units can be parallel connected to provide 144kW / 180kVA inverter power and more than 2500A charging capacity. For more detail please enter *parallel* in the search box on our website.

PowerControl – Dealing with limited generator, shore side or grid power

A current limit can be set on each AC input. The Quattro will then take account of other AC loads and use whatever is spare for charging, thus preventing the generator or mains supply from being overloaded.

PowerAssist – Boosting shore or generator power

This feature takes the principle of PowerControl to a further dimension allowing the Quattro to supplement the capacity of the alternative source. Where peak power is so often required only for a limited period, the Quattro will make sure that insufficient mains or generator power is immediately compensated for by power from the battery. When the load reduces, the spare power is used to recharge the battery.

Solar energy: AC power available even during a grid failure

The Quattro can be used in off grid as well as grid connected PV and other alternative energy systems. Loss of mains detection software is available.

System configuring

- In case of a stand-alone application, if settings have to be changed, this can be done in a matter of minutes with a DIP switch setting procedure.
- Parallel and three phase applications can be configured with VE.Bus Quick Configure and VE.Bus System Configurator software.
- Off grid, grid interactive and self-consumption applications, involving grid-tie inverters and/or MPPT Solar Chargers can be configured with Assistants (dedicated software for specific applications).

On-site Monitoring and control

Several options are available: Battery Monitor, Multi Control Panel, Color Control GX or other GX devices, smartphone or tablet (Bluetooth Smart), laptop or computer (USB or RS232).

Remote Monitoring and control

Color Control GX or other GX devices. Data can be stored and displayed on our VRM (Victron Remote Management) website, free of charge.

Remote configuring

When connected to the Ethernet, systems with a Color Control GX or other GX device can be accessed and settings can be changed remotely.



Quattro
48/5000/70-100/100



Color Control GX, showing a PV application

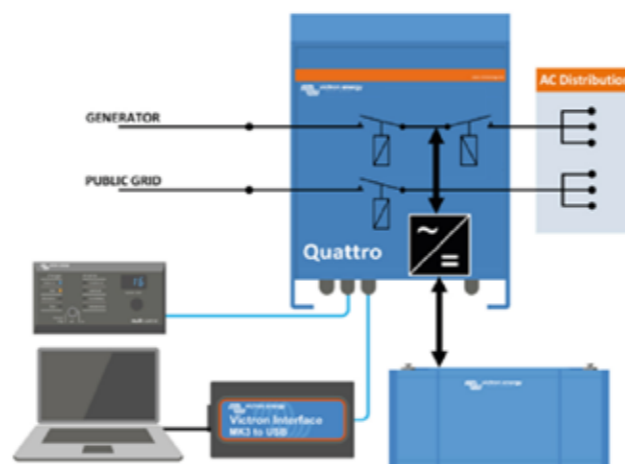

Quattro	48/3000/35-50/50 120V	12/5000/220-100/100 120V 24/5000/120-100/100 120V 48/5000/70-100/100 120V	48/10000/140-100/100 120V
PowerControl / PowerAssist		Yes	
Integrated Transfer switch		Yes	
AC inputs (2x)	Input voltage range: 90-140 VAC Input frequency: 45 – 65 Hz Power factor: 1		
Maximum feed through current	2x 50 A	2x 100 A	
INVERTER			
Input voltage range	9,5 – 17 V 19 – 33V 38 – 66 V		
Output (1)	Output voltage: 120 VAC ± 2% Frequency: 60 Hz ± 0,1%		
Cont. output power at 25°C (3)	3000 VA	5000 VA	10000 VA
Cont. output power at 25°C	2400 W	4000 W	8000 W
Cont. output power at 40°C	2200 W	3700 W	6500 W
Cont. output power at 65°C	1700 W	3000 W	4500 W
Peak power	6000 W	10000 W	20000 W
Maximum efficiency	94 %	94 / 94 / 95 %	
Zero load power	25 W	30 / 30 / 35 W	
Zero load power in AES mode	20 W	20 / 25 / 30 W	
Zero load power in Search mode	12 W	10 / 10 / 15 W	
CHARGER			
Charge voltage 'absorption' (V DC)	57,6 V	14,4 / 28,8 / 57,6 V	57,6 V
Charge voltage 'float' (V DC)	55,2 V	13,8 / 27,6 / 55,2 V	55,2 V
Storage mode (V DC)	52,8 V	13,2 / 26,4 / 52,8 V	52,8 V
Charge current house battery (A) (4)	35 A	200 / 120 / 70 A	
Charge current starter battery (A)		4 A (12V and 24V models only)	
Battery temperature sensor		Yes	
GENERAL			
Auxiliary output (5)	32 A	50 A	50 A
Programmable relay (6)		3x	
Protection (2)		a-g	
VE.Bus communication port	For parallel, split phase and three phase operation, remote monitoring and system integration		
General purpose com. port	2x		
Remote on-off	Yes		
Common Characteristics	Operating temp.: -40 to +65°C		Humidity (non-condensing): max. 95%
ENCLOSURE			
Common Characteristics	Material & Colour: aluminium (blue RAL 5012) Protection category: IP 21		
Battery-connection	Four M8 bolts (2 plus and 2 minus connections)		
120 V AC-connection	Screw terminals 13 mm ² (6 AWG)	Bolts M6	Bolts M6
Weight (kg)	42 lb 19 kg	75 / 66 / 66 lb 34 / 30 / 30 kg	128 lb 58 kg
Dimensions (hxxwxd)	14,3 x 10,2 x 8,6 inch	18,5 x 14,0 x 11,2 inch	470 x 350 x 280 mm
	36,2 x 25,8 x 21,8 mm	17,5 x 13,0 x 9,6 inch	444 x 328 x 240 mm
		17,5 x 13,0 x 9,6 inch	444 x 328 x 240 mm
STANDARDS			
Safety	EN-IEC 60335-1, EN-IEC 60335-2-29, EN-IEC 62109-1		
Emission, Immunity	EN 55014-1, EN 55014-2, EN-IEC 61000-3-2, EN-IEC 61000-3-3, IEC 61000-6-1, IEC 61000-6-2, IEC 61000-6-3		
Road vehicles	12V and 24V models: ECE R10-5		
Anti-islanding	See our website		
1) Can be adjusted to 60 Hz; 120 V 60 Hz on request	3) Non-linear load, crest factor 3:1		
2) Protection key:	4) At 25°C ambient		
a) output short circuit	5) Switches off when no external AC source available		
b) overload	6) Programmable relay that can a.o. be set for general alarm, DC under voltage or genset start/stop function		
c) battery voltage too high	AC rating: 230 V / 4 A		
d) battery voltage too low	DC rating: 4 A up to 35 VDC, 1 A up to 60 VDC		
e) temperature too high			
f) 120 VAC on inverter output			
g) input voltage ripple too high			



Digital Multi Control Panel
A convenient and low cost solution for remote monitoring, with a rotary knob to set PowerControl and PowerAssist levels.



VE.Bus Smart Dongle
Measures battery voltage and temperature and allows monitoring and control of Multis and Quattros with a smartphone or other Bluetooth enabled device.

Computer controlled operation and monitoring

Several interfaces are available:



Color Control GX and other GX devices
Monitoring and control. Locally, and also remotely on the [VRM Portal](#).



MK3-USB VE.Bus to USB interface
Connects to a USB port (see ['A guide to VEConfigure'](#))



VE.Bus to NMEA 2000 interface
Connects the device to a NMEA2000 marine electronics network. See the [NMEA2000 & MED integration guide](#)



BMV-712 Smart Battery Monitor
Use a smartphone or other Bluetooth enabled device to:

- customize settings,
- monitor all important data on single screen,
- view historical data, and to
- update the software when new features become available.

Blue Smart IP22 charger



Blue Smart IP22 12/30 (3)



Bluetooth Smart

The Blue Smart IP22 Charger is the wireless solution to monitor voltage and current, to change settings and to update the charger when new features become available.

High efficiency

With up to 94% efficiency, these chargers generate up to four times less heat when compared to the industry standard. And once the battery is fully charged, power consumption reduces to 0,5 Watt, some five to ten times better than the industry standard.

Adaptive 6-stage charge algorithm: test - bulk - absorption - recondition - float - storage

The Blue Smart Charger features a microprocessor controlled 'adaptive' battery management. The adaptive feature will automatically optimize the charging process relative to the way the battery is being used.

Storage Mode: less maintenance and aging when the battery is not in use

The storage mode kicks in whenever the battery has not been subjected to discharge during 24 hours. In the storage mode float voltage is reduced to 2,2V/cell (13,2V for a 12V battery) to minimize gassing and corrosion of the positive plates. Once a week the voltage is raised back to the absorption level to 'equalize' the battery. This feature prevents stratification of the electrolyte and sulphation, a major cause of early battery failure.

Also charges Li-Ion (LiFePO₄) batteries

LiFePO₄ batteries are charged with a simple bulk - absorption - float algorithm.

NIGHT and LOW setting

When in NIGHT or LOW mode, the output current is reduced to max. 50% of the nominal output and the charger will be totally noiseless. The NIGHT mode automatically ends after 8 hours. The LOW mode can be ended manually.

Protected against overheating

Output current will reduce as temperature increases up to 50°C, but the Blue Smart Charger will not fail.

Eleven LEDs for status indication

Charge algorithm: TEST / BULK / ABSORPTION / RECONDITION / FLOAT / STORAGE / READY.
MODE button to set: NORMAL (14,4V) / HIGH (14,7V) / RECONDITION / LI-ION.

Blue Smart IP22 Charger	12V, 1 output 15 / 20 / 30A	12V, 3 outputs 15 / 20 / 30A	24V, 1 output 8 / 12 / 16A	24V, 3 outputs 16A
Input voltage range	180 - 265 VAC		180 - 265 VAC	
Charge current, normal mode	15 / 20 / 30 A		8/12/16 A	
Charge current, NIGHT or LOW	7,5 / 10 / 15 A		4 / 6 / 8 A	
Efficiency	93%		94%	
No load power consumption	0,5 W		0,5 W	
Frequency	45 - 65 Hz		45 - 65 Hz	
Number of outputs	1	3	1	3
Charge voltage 'absorption'	Normal: 14,4V High: 14,7V Li-ion: 14,2V		Normal: 28,8V High: 29,4V Li-ion: 28,4V	
Charge voltage 'float'	Normal: 13,8V High: 13,8V Li-ion: 13,5V		Normal: 27,6V High: 27,6V Li-ion: 27,0V	
Charge voltage 'storage'	Normal: 13,2V High: 13,2V Li-ion: 13,5V		Normal: 26,4V High: 26,4V Li-ion: 27,0V	
Charge algorithm	6-stage adaptive			
Can be used as power supply	Yes			
Protection	Battery reverse polarity (fuse)	Output short circuit	Over temperature	
Operating temp. range	-20 to +50°C			
Humidity (non-condensing)	Max 98%			
ENCLOSURE				
Material & Colour	Aluminium (blue RAL 5012)			
Battery connection	Screw terminals 13 mm ² / AWG6			
230 V AC connection	Cable of 1,5 meter with CEE 7/7 plug, BS 1363 plug (UK) or AS/NZS 3112 plug (AU/NZ)			
Protection category	IP22			
Weight	1,3 kg			
Dimensions (h x w x d)	235 x 108 x 65 mm			
STANDARDS				
Safety	EN 60335-1, EN 60335-2-29			
Emission	EN 55014-1, EN 61000-6-3, EN 61000-3-2			
Immunity	EN 55014-2, EN 61000-6-1, EN 61000-6-2, EN 61000-3-3			
Automotive	E4-10R		E4-10R	

Blue Smart IP67 charger 230V



Blue Smart IP67 Charger 12/25



Bluetooth Smart enabled

The Blue Smart IP67 Charger is the wireless solution to monitor voltage and current, to change settings and to update the charger when new features become available.

With Bluetooth, the functionality of the IP67 charger is enhanced and is similar to that of our IP22 and IP65 chargers.

Completely encapsulated: waterproof, shockproof and ignition protected

Water, oil or dirt will not damage the Blue Smart IP67 Charger. The casing is made of cast aluminium and the electronics are moulded in resin.

The highest efficiency ever!

Setting a new industry standard: with 92% efficiency or better, these chargers waste three to four times less heat. And once the battery is fully charged, power consumption reduces to less than a Watt, some five to ten times better than the industry standard.

Adaptive 5-stage charge algorithm: bulk - absorption - recondition - float - storage

The Blue Smart Charger features a microprocessor controlled 'adaptive' battery management. The 'adaptive' feature will automatically optimise the charging process relative to the way the battery is being used.

Storage Mode: Less maintenance and aging when the battery is not in use

The storage mode kicks in whenever the battery has not been subjected to discharge during 24 hours. In the storage mode float voltage is reduced to 2,2 V/cell (13,2 V for a 12 V battery) to minimise gassing and corrosion of the positive plates. Once a week the voltage is raised back to the absorption level to 'equalize' the battery. This feature prevents stratification of the electrolyte and sulphation, a major cause of early battery failure.

Also charges Li-Ion (LiFePO₄) batteries

LiFePO₄ batteries are charged with a simple bulk - absorption - float algorithm.

Protected against overheating

Can be used in a hot environment such as a machine room. Output current will reduce as temperature increases up to 60°C, but the charger will not fail.

Two LEDs for status indication

Yellow LED: bulk charge (blinking fast), absorption (blinking slow), float (solid), storage (off)
Green LED: power on

Blue Smart IP67 Charger	12/7	12/13	12/17	12/25	24/5	24/8	24/12
Input voltage range and frequency	180-265 VAC 45-65 Hz						
Efficiency	93%	93%	95%	95%	94%	96%	96%
No load power consumption	0,5W						
Charge voltage 'absorption'	Normal: 14,4V High: 14,7V Li-ion: 14,2V				Normal: 28,8V High: 29,4V Li-ion: 28,4V		
Charge voltage 'float'	Normal: 13,8V High: 13,8V Li-ion: 13,5V				Normal: 27,6V High: 27,6V Li-ion: 27,0V		
Charge voltage 'storage'	Normal: 13,2V High: 13,2V Li-ion: 13,5V				Normal: 26,4V High: 26,4V Li-ion: 27,0V		
Charge current, normal mode	7A	13A	17A	25A	5A	8A	12A
Charge current, LOW	2A	4A	6A	10A	2A	3A	4A
Charge algorithm	5-stage adaptive						
Can be used as power supply	yes						
Protection	Battery reverse polarity (fuse)		Output short circuit		Over temperature		
Operating temp. range	-20 to +60°C (full rated output up to 40°C)				Derate 3% per °C above 40°C		
Humidity	Up to 100%						
Start interrupt option (SI) (12/25 and 24/12 models only)	Short circuit proof, current limit 0,5 A Output voltage: max one volt lower than main output						
ENCLOSURE							
Material & Colour	aluminium (blue RAL 5012)						
Battery-connection	Black and red cable of 1,5 meter						
230 V AC-connection	Cable of 1,5 meter with CEE 7/7 plug						
Protection category	IP67						
Weight (kg)	1,8	1,8	2,4	2,4	1,8	2,4	2,4
Dimensions (h x w x d in mm)	85 x 211 x 60	85 x 211 x 60	99 x 219 x 65	99 x 219 x 65	85 x 211 x 60	99 x 219 x 65	99 x 219 x 65
STANDARDS							
Safety	EN 60335-1, EN 60335-2-29						
Emission Immunity	EN 55014-1, EN 61000-6-3, EN 61000-3-2						
Automotive Directive	EN 55014-2, EN 61000-6-1, EN 61000-6-2, EN 61000-3-3						

Blue Smart IP65 Charger

Blue Smart IP65 Charger	12 V 4/5/7/10/15/25 A	24 V 5/8/13 A
Input voltage	230 V AC	
Efficiency	94%	95%
Standby power consumption	0,5 W	
Minimum battery voltage	Starts charging from down to 0V	
Charge voltage 'absorption'	Normal: 14,4 V High: 14,7 V Li-ion: 14,2 V	Normal: 28,8 V High: 29,4 V Li-ion: 28,4 V
Charge voltage 'float'	Normal: 13,8 V High: 13,8 V Li-ion: 13,5 V	Normal: 27,6 V High: 27,6 V Li-ion: 27,0 V
Charge voltage 'storage'	Normal: 13,2 V High: 13,2 V Li-ion: 13,5 V	Normal: 26,4 V High: 26,4 V Li-ion: 27,0 V
Charge current	4 / 5 / 7 / 10 / 15 / 25 A	5 / 8 / 13 A
Charge current in low current mode	2 / 2 / 2 / 3 / 4 / 10 A	2 / 3 / 4 A
Temperature compensation (lead-acid batteries only)	16 mV/°C	32 mV/°C
Can be used as power supply	Yes	
Back current drain	0,7 Ah/month (1 mA)	
Protection	Reverse polarity	Output short circuit Over temperature
Operating temp. range	-30 to + 50 °C (full rated output up to 30 °C) (cables retain flexibility at low temperature)	
Humidity (non condensing)	Max 95%	
ENCLOSURE		
Battery-connection	Black and red cable of 1,5 meter	
230 V AC-connection	Cable of 1,5 meter with CEE 7/7, BS 1363 plug (UK) or AS/NZS 3112 plug	
Protection category	IP65 (splash and dust proof)	
Weight	IP65 12 V 25 A - 24 V 13 A: 1,9 kg Other: 0,9 kg	
Dimensions (h x w x d)	IP65s 12 V 4/5 A : 45 x 81 x 182 mm	IP65 12 V 7 A 24 V 5 A : 47 x 95 x 190 mm
	IP65 12 V 10/15 A 24 V 8 A : 60 x 105 x 190 mm	IP65 12 V 25 A 24 V 13 A : 75 x 140 x 240 mm
STANDARDS		
Safety	EN 60335-1, EN 60335-2-29	
Emission	EN 55014-1, EN 61000-6-3, EN 61000-3-2	
Immunity	EN 55014-2, EN 61000-6-1, EN 61000-6-2, EN 61000-3-3	

victron energy BLUE POWER
 www.victronenergy.com
 Customer support: sales@victronenergy.com



Blue Smart IP65 Charger

The professional's choice



- Water, dust and chemical resistant
- Seven step smart charge algorithm
- Recovery of fully discharged 'dead' batteries
- Automatic power supply function
- Severe cold performance: down to -30°C
- Several other battery life enhancing features
- Low power mode to charge smaller batteries
- **Li-ion** battery mode
- Setup and configure, readout of voltage and current by **Bluetooth Smart**



IP65 - Charger Guide

Blue Smart IP65 Charger

Battery size Ah	4 & 5 A	7 A	12V 10 A	15 A	25 A	5 A	24V 8 A	13 A
20-30 Ah	30-40 Ah	40-50 Ah	50-60 Ah	60-70 Ah	70-80 Ah	80-90 Ah	90-100 Ah	100-120 Ah
Your IP65 Charger	12/445	12/7	12/10	12/15	12/25	24/5	24/8	24/13
CLASSIC	Green	Green	Green	Green	Green	Blue	Blue	Blue
MODERN	Green	Green	Green	Green	Green	Blue	Blue	Blue

Recommended
This is the best charger for this type of battery. The battery will be charged in the most efficient way.

OK
This charger can be used for this battery. It is possible that it takes longer to charge the battery than using a recommended charger.

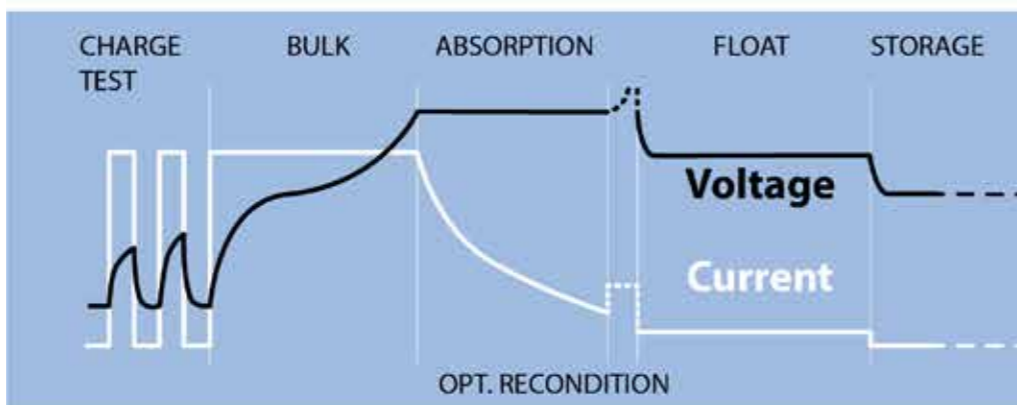

Ultra high efficiency "green" battery charger
With up to 95% efficiency, these chargers generate up to four times less heat when compared to the industry standard. And once the battery is fully charged, power consumption reduces to 0,5 Watt, some five to ten times better than the industry standard.

Reconditioning
A lead-acid battery that has been insufficiently charged or has been left discharged during days or weeks will deteriorate due to sulfation. If caught in time, sulfation can sometimes be partially reversed by charging the battery with low current up to a higher voltage.

Recovery function for fully discharged batteries
Most reverse polarity protected chargers will not recognize, and therefore not recharge a battery which has been discharged to zero or nearly zero Volts. The **Blue Smart IP65 Charger** however will attempt to recharge a fully discharged battery with low current and resume normal charging once sufficient voltage has developed across the battery terminals.



The VictronConnect app
Setup, readout and configure your **Blue Smart IP65 Charger** via your smartphone.

You can display the status of your charger and battery and even control the functions of your charger using the VictronConnect app. On your screen the readout of voltage and current is default available.

Download your app for iOS and Android here at <https://www.victronenergy.com/live/victronconnect:start>

- Durable, safe and silent**
- Low thermal stress on the electronic components.
 - Protection against ingress of dust, water and chemicals.
 - Protection against overheating: the output current will reduce as temperature increases up to 60°C, but the charger will not fail.
 - The chargers are totally silent: no cooling fan or any other moving parts.

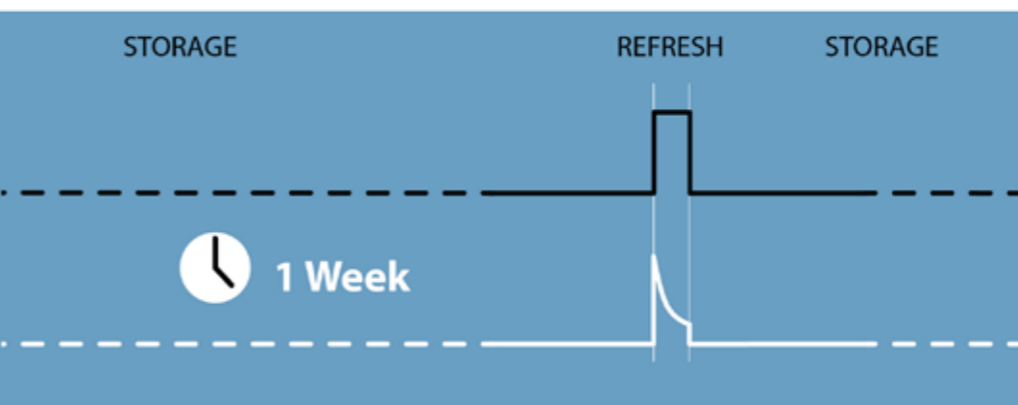

Storage mode: less corrosion of the positive plates
Even the lower float charge voltage that follows the absorption period will cause grid corrosion. It is therefore essential to reduce the charge voltage even further when the battery remains connected to the charger during more than 48 hours

Temperature compensated charging
The optimal charge voltage of a lead-acid battery varies inversely with temperature. The **Blue Smart IP65 Charger** measures ambient temperature during the test phase and compensates for temperature during the charge process. The temperature is measured again when the charger is in low current mode during float or storage. Special settings for a cold or hot environment are therefore not needed.

Li-ion battery mode
The **Blue Smart IP65 Charger** uses a specific charging algorithm for Li-ion (LiFePO₄) batteries, with automatic Li-ion under voltage protection reset.

Phoenix Smart IP43 charger



Bluetooth Smart enabled

Any Bluetooth enabled smart phone, tablet or other device can be used to monitor, to change settings and to update the charger when new software features become available.

Phoenix Smart (1+1): two outputs to charge 2 battery banks

The second output, limited to approximately 3A and with a slightly lower output voltage, is intended to top up a starter battery.

Phoenix Smart (3): three full current outputs to charge 3 battery banks

Each output can supply the full rated output current. But the total of the 3 outputs combined can never exceed the current rating of the charger.

Automatic voltage compensation

The charger compensates for voltage drop over the DC cabling by slightly increasing output voltage when the DC current increases. Please see the manual for details.

Adaptive 5-stage charge algorithm: bulk – absorption – recondition – float – storage

The Phoenix Smart Charger features our well-known 'adaptive' battery management system that can be preset to suit different types of batteries. The 'adaptive' feature will automatically optimise the charge process relative to the way the battery is being used.

The right amount of charge: variable absorption time

When only shallow discharges occur (a yacht connected to shore power for example) the absorption time is kept short in order to prevent overcharging of the battery. After a deep discharge the absorption time is automatically increased to make sure that the battery will be fully charged.

Preventing damage due to excessive gassing: the BatterySafe mode (see fig. 2)

If, in order to quickly charge a battery, a high charge current in combination with a high absorption voltage has been chosen, the charger will prevent damage due to excessive gassing by automatically limiting the rate of voltage increase once the gassing voltage has been reached (see the charge curve between 14,4 V and 15,0 V in fig. 2).

Less maintenance and aging when the battery is not in use: the Storage Mode (see fig. 1 & 2)

The Storage Mode kicks in whenever the battery has not been subjected to discharge during 24 hours. In the Storage Mode float voltage is reduced to 2,2 V/cell (13,2 V for a 12 V battery) to minimise gassing and corrosion of the positive plates. Once a week the voltage is raised back to the absorption level to 'equalize' the battery. This feature prevents stratification of the electrolyte and sulphation, a major cause of early battery failure.

Also charges Li-ion (LiFePO₄) batteries

Charger on-off control can be implemented by connecting a relay or open collector optocoupler output from a Li-ion BMS to the remote on-off port. Alternatively full control of voltage and current can be achieved with Bluetooth.

Fully programmable charge algorithm

The charge algorithm can be programmed with help of Bluetooth or the VE.Direct interface. Three preprogrammed algorithms can be selected with the mode button (see specifications).

Remote on-off

The remote on/off consists of two terminals: Remote H and Remote L. A remote on/off switch or relay contact can be connected between H and L. Alternatively, terminal H can be pulled high, or terminal L can be pulled low. See manual for details.

VE.Direct interface

For a wired data connection to a Color Control panel, PC or other devices. Please see the VictronConnect app under Downloads / Software on our website.

Programmable relay

Can be programmed using the VE.Direct interface or a Bluetooth enabled device to trip on an alarm or other events.

Learn more about batteries and battery charging

For more information about adaptive charging please look under Downloads / White papers on our website.



Phoenix Smart 12/50(1+1)



Phoenix Smart 12/50(3)

Phoenix Smart IP43 Charger	12V, 2 outputs 12/30(1+1) 12/50(1+1)	12V, 3 outputs 12/30(3) 12/50(3)	24V, 2 outputs 24/16(1+1) 24/25(1+1)	24V, 3 outputs 24/16(3) 24/25(3)
Input voltage	230 VAC (range: 210 – 250 V)			
DC input voltage range	290 – 355 VDC			
Frequency	45-65 Hz			
Power factor	0,7			
Back current drain	AC disconnected: < 0,1 mA		AC connected and charger remote off: < 6 mA	
No load power consumption	1 W			
Efficiency	12/30: 94% 12/50: 92%	12/30: 94% 12/50: 92%	94%	94%
Charge voltage 'absorption'	Normal: 14,4V High: 14,7V	Li-ion: 14,2V	Normal: 28,8V High: 29,4V	Li-ion: 28,4V
Charge voltage 'float'	Normal: 13,8V High: 13,8V	Li-ion: 13,5V	Normal: 27,6V High: 27,6V	Li-ion: 27,0V
Storage mode	Normal: 13,2V High: 13,2V	Li-ion: 13,5V	Normal: 26,4V High: 26,4V	Li-ion: 27,0V
Fully programmable	Yes, with Bluetooth and/or VE.Direct			
Charge current house battery	30 / 50 A	30 / 50 A	16 / 25 A	16 / 25 A
Low current mode	15 / 25 A	15 / 25 A	8 / 12,5 A	8 / 12,5 A
Charge current starter battery	3 A (1+1 output models only)			
Charge algorithm	5 stage adaptive			
Protection	Battery reverse polarity (fuse, not user accessible) / Output short circuit / Over temperature			
Can be used as power supply	Yes, output voltage can be set with Bluetooth and/or VE.Direct			
Operating temp. range	-20 to 60°C (0 - 140°F) Rated output current up to 40°C, derate linearly to 20% at 60°C			
Humidity (non-condensing)	max 95%			
Relay (programmable)	DC rating: 5 A up to 28 VDC			
ENCLOSURE				
Material & Colour	aluminium (blue RAL 5012)			
Battery-connection	Screw terminals 16 mm ² (AWG6)			
AC-connection	IEC 520 C14 inlet with retainer clip (AC cord with country specific plug must be ordered separately)			
Protection category	IP43 (electronic components), IP22 (connection area)			
Weight kg (lbs)	3,5 kg			
Dimensions (hwxwd)	180 x 249 x 100 mm (7.1 x 9.8 x 4.0 inch)			
STANDARDS				
Safety	EN 60335-1, EN 60335-2-29			
Emission	EN 55014-1, EN 61000-6-3, EN 61000-3-2			
Immunity	EN 55014-2, EN 61000-6-1, EN 61000-6-2, EN 61000-3-3			
Vibration	IEC68-2-6:10-150Hz/1.0G			



Retainer clip (included)



AC cord (must be ordered separately)

Plug options:
Europe: CEE 7/7
UK: BS 1363
Australia/New Zealand: AS/NZS 3112

Charge curves: up to the gassing voltage (fig.1), and exceeding the gassing voltage (fig.2)

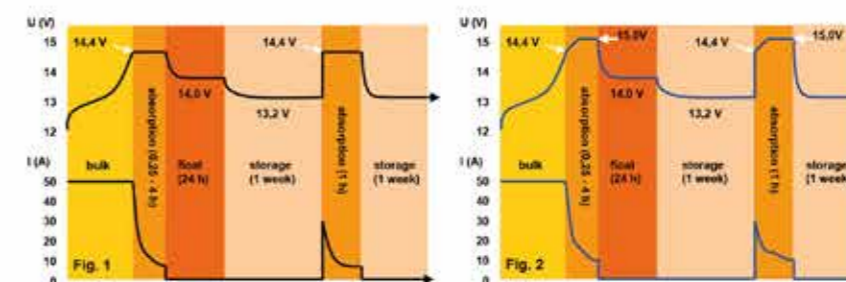

Centaur charger 12/24V



Centaur
Battery Charger 24/30

Quality without compromise

Aluminium epoxy powder coated cases with drip shield and stainless steel fixings withstand the rigors of an adverse environment: heat, humidity and salt air. Circuit boards are protected with an acrylic coating for maximum corrosion resistance. Temperature sensors ensure that power components will always operate within specified limits, if needed by automatic reduction of output current under extreme environmental conditions.

Universal 90-265V AC Input voltage range and also suitable for DC supply (AC-DC and DC-DC operation)
All models will operate without any adjustment needed over a 90 to 265 Volt input voltage range, whether 50 Hz or 60 Hz.

The chargers also accept a 90-400 V DC supply.

Three outputs that each can supply the full output current

Three isolated outputs to simultaneously charge 3 battery banks
Each output is capable to supply the full rated current.

Three-stage charging, with temperature compensation

The Centaur charges at bulk rate until the output has reduced to 70% of the rated Amps, at which a 4 hour timer begins. After the timed period the charger switches to float rate.

An internal temperature sensor is used to compensate the charge voltage with $-2 \text{ mV}/^{\circ}\text{C}$ ($-1 \text{ mV}/^{\circ}\text{F}$) per cell. A DIP switch is available to select the optimum charge/float voltages for Flooded Lead-acid, Gel or AGM batteries.

Learn more about batteries and battery charging

To learn more about batteries and charging batteries (including the pro's and cons of multi-bank charging and intelligent charging), please refer to our book 'Electricity on Board' (available free of charge from Victron Energy and downloadable from www.victronenergy.com).

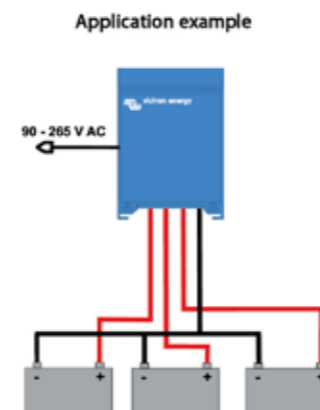
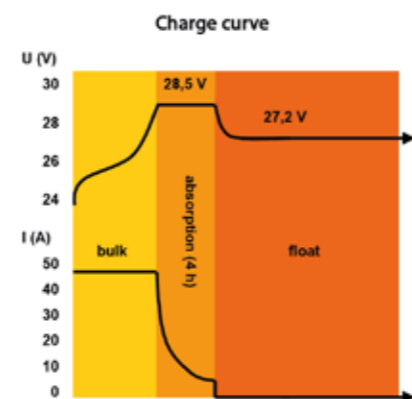

Centaur Charger	12/20	12/30 24/16	12/40	12/50	12/60 24/30	12/80 24/40	12/100 24/60
Input voltage (V AC)	90 - 265						
Input voltage (V DC)	90 - 400						
Input frequency (Hz)	45 - 65						
Power factor	1						
Charge voltage 'absorption' (V DC)	14.3 / 28.5 (1)						
Charge voltage 'float' (V DC)	13.5 / 27.0 (1)						
Output banks	3						
Charge current (A) (2)	20	30 / 16	40	50	60 / 30	80 / 40	100 / 60
Total output ammeter	Yes						
Charge characteristic	I/U/I (Three stage charging)						
Recommended battery capacity (Ah)	80 - 200	120 - 300 45 - 150	160 - 400	200 - 500	240 - 600 120 - 300	320 - 800 160 - 400	400 - 1000 240 - 600
Temperature sensor	Internal, $-2 \text{ mV}/^{\circ}\text{C}$ ($-1 \text{ mV}/^{\circ}\text{F}$) per cell						
Forced cooling	Yes, temperature and current controlled fan						
Protection	Output short circuit, over temperature						
Operating temp. range	-20 to 60°C (0 - 140°F)						
Ignition protected	Yes						
Humidity (non condensing)	max 95%						

ENCLOSURE

Material & Colour	aluminium (blue RAL 5012)						
Battery-connection	M6 studs	M6 studs	M8 studs	M8 studs	M8 studs	M8 studs	M8 studs
AC-connection	screw-clamp 4 mm ² (AWG 6)						
Protection category	IP 20						
Weight kg (lbs)	3,8 (8.4)	3,8 (8.4)	5 (11)	5 (11)	5 (11)	12 (26)	12 (26)
Dimensions hxxwxd in mm (hxxwd in inches)	355x215x110 (14.0x8.5x4.3)	355x215x110 (14.0x8.5x4.3)	426x239x135 (16.8x9.4x5.3)	426x239x135 (16.8x9.4x5.3)	426x239x135 (16.8x9.4x5.3)	505x255x130 (19.9x10.0x5.2)	505x255x130 (19.9x10.0x5.2)

STANDARDS

Safety	EN 60335-1, EN 60335-2-29, UL 1236						
Emission Immunity	EN 55014-1, EN 61000-3-2						
Automotive Directive	EN 55014-2, EN 61000-3-3						

- 1) Standard setting. Optimum charge/float voltages for Flooded Lead-acid, Gel-Cell or AGM batteries selectable by DIP switch.
- 2) Up to 40°C (100°F) ambient. Output will reduce to approximately 80% of nominal at 50°C (120°F) and 60% of nominal at 60°C (140°F).



BMV-700 Battery Monitor

The BMV-700 Battery Monitor features an advanced microprocessor control system combined with high resolution measuring systems for battery voltage and charge/discharge current. Besides this, the software includes complex calculation algorithms, like Peukert's formula, to exactly determine the state of charge of the battery. The BMV-700 selectively displays battery voltage, current, consumed Ah or time to go.



Battery Alarm

An excessively high or low battery voltage is indicated by an audible and visual alarm.

Installation made easy

1. Fasten the separate mounting plate (A) to the wall where you want to place the battery charger, and simply hook up the Centaur.
2. Secure the bottom of the backside (B) to the wall.



Phoenix battery charger 12/24V

Application Examples

Motorhomes

Ambulances

Coffee cart Espresso

Systems

Accessories

Tools

Technical information



Phoenix Charger
12V 30A



Phoenix Charger
24V 25A

Adaptive 4-stage charge characteristic: bulk – absorption – float – storage
The Phoenix Charger features a microprocessor controlled 'adaptive' battery management system that can be preset to suit different types of batteries. The 'adaptive' feature will automatically optimise the process relative to the way the battery is being used.

The right amount of charge: variable absorption time
When only shallow discharges occur (a yacht connected to shore power for example) the absorption time is kept short in order to prevent overcharging of the battery. After a deep discharge the absorption time is automatically increased to make sure that the battery is completely recharged.

Preventing damage due to excessive gassing: the BatterySafe mode (see fig. 2 below)
If, in order to quickly charge a battery, a high charge current in combination with a high absorption voltage has been chosen, the Phoenix Charger will prevent damage due to excessive gassing by automatically limiting the rate of voltage increase once the gassing voltage has been reached (see the charge curve between 14,4 V and 15,0 V in fig. 2 below).

Less maintenance and aging when the battery is not in use: the Storage mode (see fig. 1 & 2 below)
The storage mode kicks in whenever the battery has not been subjected to discharge during 24 hours. In the storage mode float voltage is reduced to 2,2 V/cell (13,2 V for 12 V battery) to minimize gassing and corrosion of the positive plates. Once a week the voltage is raised back to the absorption level to 'equalize' the battery. This feature prevents stratification of the electrolyte and sulphation, a major cause of early battery failure.

To increase battery life: temperature compensation
Every Phoenix Charger comes with a battery temperature sensor. When connected, charge voltage will automatically decrease with increasing battery temperature. This feature is especially recommended for sealed batteries and/or when important fluctuations of battery temperature are expected.

Battery voltage sense
In order to compensate for voltage loss due to cable resistance, Phoenix Chargers are provided with a voltage sense facility so that the battery always receives the correct charge voltage.

Universal 90-265 V AC Input voltage range and also suitable for DC supply (AC-DC and DC-DC operation)
The chargers will accept a 90-400 V DC supply.

Computer interface
Every Phoenix Charger is ready to communicate with a computer through its RS-485 data port. Together with our VEConfigure software, which can be downloaded free of charge from our website www.victronenergy.com and the data link MK3-USB (see accessories), all parameters of the chargers can be customised.

Learn more about batteries and battery charging
To learn more about batteries and charging batteries, please refer to our book 'Energy Unlimited' (available free of charge from Victron Energy and downloadable from www.victronenergy.com). For more information about adaptive charging please look under Technical Information on our website.

Charge curves: up to the gassing voltage (fig.1), and exceeding the gassing voltage (fig.2)

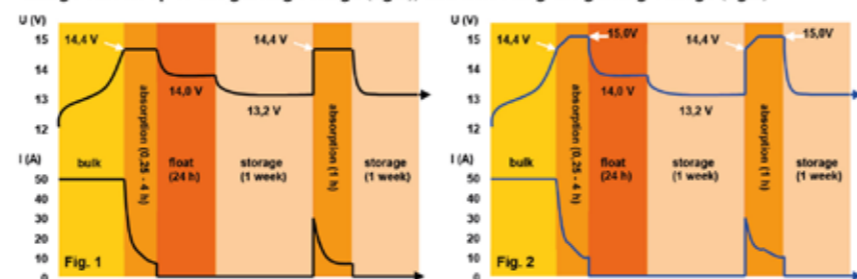

Phoenix Charger	12/30	12/50	24/16	24/25
Input voltage range (V AC)	90-265			
Input voltage range (V DC)	90-400			
Frequency (Hz)	45-65			
Power factor	1			
Charge voltage 'absorption' (V DC)	14,4	14,4	28,8	28,8
Charge voltage 'float' (V DC)	13,8	13,8	27,6	27,6
Storage mode (V DC)	13,2	13,2	26,4	26,4
Charge current house batt. (A) (2)	30	50	16	25
Charge current starter batt. (A)	4	4	4	4
Charge characteristic	4 stage adaptive			
Battery capacity (Ah)	100-400	200-800	100-200	100-400
Temperature sensor	✓	✓	✓	✓
Can be used as power supply	✓	✓	✓	✓
Forced cooling	✓	✓	✓	✓
Protection (1)	a,b,c,d			
Operating temp. range	-20 to 60°C (0 - 140°F)			
Humidity (non-condensing)	max 95%			
ENCLOSURE				
Material & Colour	aluminium (blue RAL 5012)			
Battery-connection	M6 studs			
AC-connection	screw-clamp 4 mm ² (AWG 11)			
Protection category	IP 21			
Weight kg (lbs)	3,8 (8)			
Dimensions (hwxwd in mm and inches)	350x200x108 mm (13.8x7.9x4.3 inch)			
STANDARDS				
Safety	EN 60335-1, EN 60335-2-29			
Emission Immunity	EN 55014-1, EN 61000-3-2,			
Automotive Directive	EN 55014-2, EN 61000-3-3			
Vibration	IEC68-2-6:10-150Hz/1.0G			
1) Protection key:	a) Output short circuit		c) Battery voltage too high	
	b) Battery reverse polarity detection		d) Temperature too high	
	2) Up to 40°C (100°F) ambient			



Battery Alarm
An excessively high or low battery voltage is indicated by an audible and visual alarm, and potential free contacts.



Phoenix Charger Control
The PCC panel provides remote control and monitoring of the charge process with LED indication of the charger status. In addition, the remote panel also offers output current adjustment that can be used to limit the output current and thus the power drawn from the AC supply. This is particularly useful when operating the charger from limited shore power or small gensets. The panel can also be used to change the battery charging parameters. The brightness of the LEDs is automatically reduced during night time. Connection to the charger is with a standard UTP-cable.



BMV-700 Battery Monitor
The BMV-700 Battery Monitor features an advanced microprocessor control system combined with high resolution measuring systems for battery voltage and charge/discharge current. Besides this, the software includes complex calculation algorithms, like Peukert's formula, to exactly determine the state of charge of the battery. The BMV-700 selectively displays battery voltage, current, consumed Ah or time to go.

Skylla-I battery charger 24V

Li-Ion ready



Skylla-I 24/100 (3)



Skylla-I 24/100 (1+1)

Skylla-I (1+1): two outputs to charge 2 battery banks

The Skylla-I (1+1) features 2 isolated outputs. The second output, limited to approximately 4A and with a slightly lower output voltage, is intended to top up a starter battery.

Skylla-I (3): three full current outputs to charge 3 battery banks

The Skylla-I (3) features 3 isolated outputs. All outputs can supply the full rated output current.

Rugged

Aluminium epoxy powder coated cases with drip shield and stainless steel fixings withstand the rigors of an adverse environment: heat, humidity and salt air. Circuit boards are protected with an acrylic coating for maximum corrosion resistance. Temperature sensors ensure that power components will always operate within specified limits, if needed by automatic reduction of output current under extreme environmental conditions.

Flexible

Next to a CAN bus (NMEA2000) interface, a rotary switch, DIP switches and potentiometers are available to adapt the charge algorithm to a particular battery and its conditions of use. Please refer to the manual for a complete overview of the possibilities.

Important features:

Synchronised parallel operation

Several chargers can be synchronised with the CAN bus interface. This is achieved by simply interconnecting the chargers with RJ45 UTP-cables. Please see the manual for details.

The right amount of charge for a lead-acid battery: variable absorption time

When only shallow discharges occur the absorption time is kept short in order to prevent overcharging of the battery. After a deep discharge the absorption time is automatically increased to make sure that the battery is completely recharged.

Preventing damage due to excessive gassing: the BatterySafe mode

If, in order to quickly charge a battery, a high charge current in combination with a high absorption voltage has been chosen, the Skylla-I will prevent damage due to excessive gassing by automatically limiting the rate of voltage increase once the gassing voltage has been reached.

Less maintenance and aging when the battery is not in use: the Storage mode

The storage mode kicks in whenever the battery has not been subjected to discharge during 24 hours. In the storage mode float voltage is reduced to 2,2V/cell (26,4V for 24V battery) to minimise gassing and corrosion of the positive plates. Once a week the voltage is raised back to the absorption level to 'refresh' the battery. This feature prevents stratification of the electrolyte and sulphation, a major cause of early battery failure.

To increase battery life: temperature compensation

Every Skylla-I comes with a battery temperature sensor. When connected, charge voltage will automatically decrease with increasing battery temperature. This feature is especially recommended for sealed lead-acid batteries and/or when important fluctuations of battery temperature are expected.

Battery voltage sense

In order to compensate for voltage loss due to cable resistance, the Skylla-I is provided with a voltage sense facility so that the battery always receives the correct charge voltage.

Suitable for AC and DC supply (AC-DC and DC-DC operation)

The chargers also accept a DC supply.

Use as a power supply

As a result of the perfectly stabilized output voltage, the Skylla-I can be used as a power supply if batteries or large buffer capacitors are not available.

Li-Ion (LiFePO4) ready

Simple charger on-off control can be implemented by connecting a relay or open collector optocoupler output from a Li-Ion BMS to the remote control port of the charger. Alternatively complete control of voltage and current can be achieved by connecting to the galvanically isolated CAN bus port.

Learn more about batteries and battery charging

To learn more about batteries and charging batteries, please refer to our book 'Energy Unlimited' (available free of charge from Victron Energy and downloadable from www.victronenergy.com).

Skylla-I	24/80 (1+1)	24/80 (3)	24/100 (1+1)	24/100 (3)
Input voltage (VAC)	230V			
Input voltage range (VAC)	185-265V			
Input voltage range (VDC)	180-350V			
Maximum AC input current @ 180 VAC	16A		20A	
Frequency (Hz)	45-65Hz			
Power factor	0,98			
Charge voltage 'absorption' (VDC) (1)	28,8V			
Charge voltage 'float' (VDC)	27,6V			
Charge voltage 'storage' (VDC)	26,4V			
Charge current (A) (2)	80A	3 x 80A (max total output: 80A)	100A	3 x 100A (max total output: 100A)
Charge current starter batt. (A)	4A	n. a.	4	n. a.
Charge algorithm	7 stage adaptive			
Battery capacity (Ah)	400-800Ah		500-1000Ah	
Charge algorithm, Li-Ion	3 stage, with on-off control or CAN bus control			
Temperature sensor	Yes			
Can be used as power supply	Yes			
Remote on-off port	Yes (can be connected to a Li-Ion BMS)			
CAN bus communication port (VE.Can)	Two RJ45 connectors, NMEA2000 protocol, galvanically isolated			
Synchronised parallel operation	Yes, with VE.Can			
Alarm relay	DPST	AC rating: 240VAC/4A	DC rating: 4A up to 35VDC, 1A up to 60VDC	
Forced cooling	Yes			
Protection	Battery reverse polarity (fuse)		Output short circuit	Over temperature
Operating temp. range	-20 to 60°C (Full output current up to 40°C)			
Humidity (non-condensing)	max 95%			
ENCLOSURE				
Material & Colour	aluminium (blue RAL 5012)			
Battery-connection	M8 bolts			
230 VAC-connection	screw-clamp 10mm ² (AWG 7)			
Protection category	IP 21			
Weight kg (lbs)	7kg (16 lbs)			
Dimensions hoxwd in mm (hoxwd in inches)	405 x 250 x 150 (16.0 x 9.9 x 5.9)			
STANDARDS				
Safety	EN 60335-1, EN 60335-2-29			
Emission	EN 55014-1, EN 61000-6-3, EN 61000-3-2			
Immunity	EN 55014-2, EN 61000-6-1, EN 61000-6-2, EN 61000-3-3			
1) Output voltage range 20-36V. Can be set with rotary switch or potentiometers.		2) Up to 40°C (100°F) ambient. Output will reduce to 80% at 50°C, and to 60% at 60°C.		



BMV-700 Battery Monitor

The BMV-700 Battery Monitor features an advanced microprocessor control system combined with high resolution measuring systems for battery voltage and charge/discharge current. The software includes complex calculation algorithms, like Peukert's formula, to exactly determine the state of charge of the battery. The BMV-700 selectively displays battery voltage, battery current, consumed Ah or time to go.



Skylla-I Control

The Skylla-I Control panel provides remote control and monitoring of the charge process with LED status indication. In addition, the remote panel also offers input current adjustment that can be used to limit the input current and thus the power drawn from the AC supply. This is particularly useful when operating the charger from limited shore power or small gensets. The panel can also be used to change several battery charging parameters. Several control panels can be connected to one charger or to a set of synchronised and parallel connected chargers.

Skylla TG charger 24/48V 230V



Skylla TG 24 50



Skylla TG 24 50 3 phase



Skylla TG 24 100

Perfect chargers for any type of battery

Charge voltage can be precisely adjusted to suit any sealed or unsealed battery system. In particular, sealed maintenance free batteries must be charged correctly in order to ensure a long service life. Overvoltage will result in excessive gassing and venting of a sealed battery. The battery will dry out and fail.

Suitable for AC and DC supply (AC-DC and DC-DC operation)

Except for the 3-phase input models, the chargers also accept a DC supply.

Controlled charging

Every TG Charger has a microprocessor, which accurately controls the charging in three steps. The charging process takes place in accordance with the IUoUo characteristic and charges more rapidly than other processes.

Use of TG Chargers as a power supply

As a result of the perfectly stabilized output voltage, a TG Charger can be used as a power supply if batteries or large buffer capacitors are not available.

Two outputs to charge 2 battery banks (24V models only)

The TG Chargers feature 2 isolated outputs. The second output, limited to approximately 4A and with a slightly lower output voltage, is intended to top up a starter battery.

To increase battery life: temperature compensation

Every Skylla TG Charger comes with a battery temperature sensor. When connected, charge voltage will automatically decrease with increasing battery temperature. This feature is especially recommended for sealed batteries which otherwise might be overcharged and dry out due to venting.

Battery voltage sense

In order to compensate for voltage loss due to cable resistance, TG Chargers are provided with a voltage sense facility so that the battery always receives the correct charge voltage.

Learn more about batteries and battery charging

To learn more about batteries and charging batteries, please refer to our book 'Energy Unlimited' (available free of charge from Victron Energy and downloadable from www.victronenergy.com).

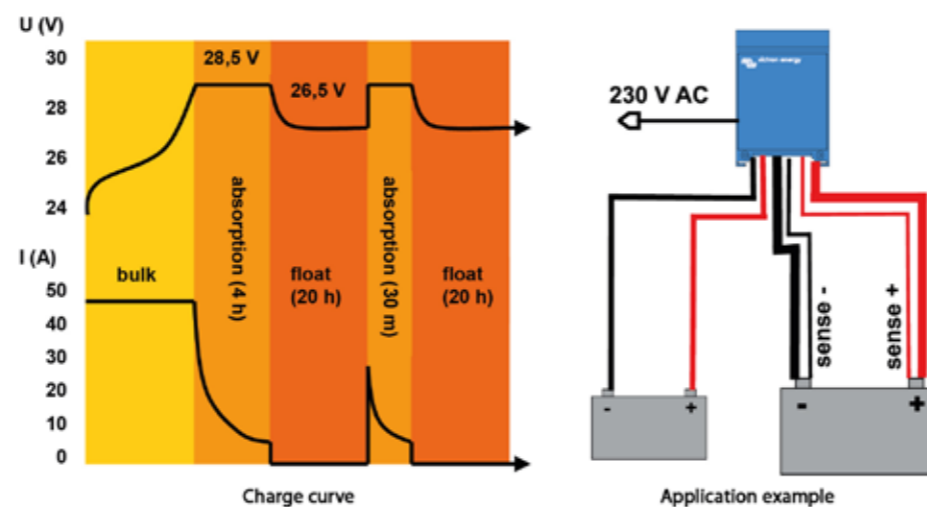

Skylla	24/30 TG 24/50 TG	24/50 TG 3 phase	24/80 TG	24/100 TG	24/100 TG 3 phase	48/25 TG	48/50 TG
Input voltage (V AC)	120/230	3 x 400	230	230	3 x 400	230	230
Input voltage range (V AC)	95-264	320-450	185-264	185-264	320-450	185-264	185-264
Input voltage range (V DC)	180-400	n.a.	180-400	180-400	n.a.	180-400	180-400
Frequency (Hz)				45-65			
Power factor				1			
Charge voltage 'absorption' (V DC)	28,5	28,5	28,5	28,5	28,5	57	57
Charge voltage 'float' (V DC)	26,5	26,5	26,5	26,5	26,5	53	53
Charge current house batt. (A) (2)	30 / 50	50	80	100	100	25	50
Charge current starter batt. (A)	4	4	4	4	4	n.a.	n.a.
Charge characteristic				IUoUo (three step)			
Battery capacity (Ah)	150-500	250-500	400-800	500-1000	500-1000	125-250	250-500
Temperature sensor				√			
Can be used as power supply				√			
Remote alarm						Potential free contacts 60V / 1A (1x NO and 1x NC)	
Forced cooling				√			
Protection (1)				a,b,c,d			
Operating temp. range				-40 to +50°C (-40 - 122°F)			
Humidity (non-condensing)				max 95%			

ENCLOSURE

Material & Colour	aluminium (blue RAL 5012)						
Battery-connection	M8 studs						
230 V AC-connection	screw-clamp 2.5 mm ² (AWG 6)						
Protection category	IP 21						
Weight kg (lbs)	5,5 (12.1)	13 (28)	10 (22)	10 (22)	23 (48)	5,5 (12.1)	10 (12.1)
Dimensions h x w x d in mm (h x w x d in inches)	365 x 250 x 147 (14.4 x 9.9 x 5.8)	365 x 250 x 257 (14.4 x 9.9 x 10.1)	365 x 250 x 257 (14.4 x 9.9 x 10.1)	365 x 250 x 257 (14.4 x 9.9 x 10.1)	515 x 260 x 265 (20 x 10.2 x 10.4)	365 x 250 x 147 (14.4 x 9.9 x 5.8)	365 x 250 x 257 (14.4 x 9.9 x 10.1)

STANDARDS

Safety	EN 60335-1, EN 60335-2-29
Emission	EN 55014-1, EN 61000-3-2
Immunity	EN 55014-2, EN 61000-3-3

1) Protection:
a. Output short circuit
b. Battery reverse polarity detection
2) Up to 40°C (100°F) ambient

c. Battery voltage too high
d. Temperature too high



BMV-700 Battery Monitor

The BMV-700 Battery Monitor features an advanced microprocessor control system combined with high resolution measuring systems for battery voltage and charge/discharge current. Besides this, the software includes complex calculation algorithms, like Peukert's formula, to exactly determine the state of charge of the battery. The BMV-700 selectively displays battery voltage, current, consumed Ah or time to go.



Skylla Control

The Skylla Control allows you to alter the charge current and see the system status. Altering the charge current is useful if the shore power fuse is limited: the AC current drawn by the battery charger can be controlled by limiting the maximum output current, thereby preventing the shore power fuse from blowing.



Charger Switch

A remote on-off switch



Battery Alarm

An excessively high or low battery voltage is indicated by an audible and visual alarm.

Orion-Tr Smart DC-DC charger non-isolated



Orion-Tr Smart non-isolated 12/12-30



Orion-Tr Smart non-isolated 12/12-30



Bluetooth Smart enabled

Any Bluetooth enabled smart phone, tablet or other device can be used to monitor, to change settings and to update the charger when new software features become available.

Fully programmable

- Battery charge algorithm (configurable) or fixed output.
- Smart alternator compatibility: engine running detection mechanism.

Adaptive 3-stage charge algorithm: bulk – absorption – float

- For lead acid batteries it is important that during shallow discharges the absorption time is kept short in order to prevent overcharging of the battery. After a deep discharge the absorption time is automatically increased to make sure that the battery is completely recharged.
- For lithium batteries absorption time is fixed, default 2 hours.
- Alternatively, a fixed output voltage can be chosen.

Remote on-off

A remote on/off switch or relay contact can be connected to a two-pole connector. Alternatively, the H terminal (right) of the two-pole connector can be switched to battery plus, or the L terminal (left) of the two pole connector can be switched to battery minus (or the chassis of a vehicle, for example).

All models are short circuit proof and can be paralleled to increase output current

An unlimited number of units can be connected in parallel.

High temperature protected

The output current will reduce at high ambient temperature.

IP43 protection

When installed with the screw terminals oriented downwards.

Screw terminals

No special tools needed for installation.

Input fuse (not replaceable)

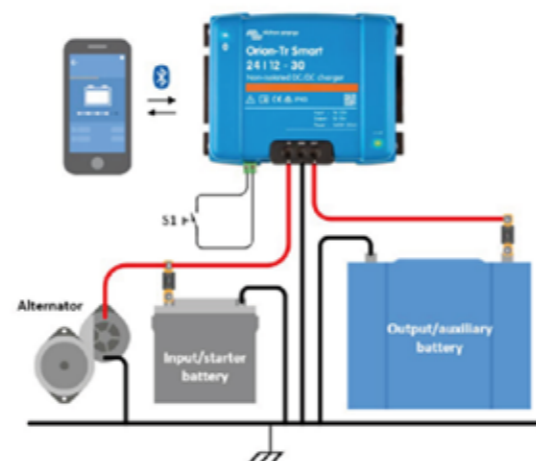

Orion-Tr Smart Chargers non-isolated 360 - 400 Watt	12/12-30 (360W)	12/24-15 (360W)	24/12-30 (360W)	24/24-17 (400W)
Input voltage range (1)	10-17V	10-17V	20-35V	20-35V
Under voltage shut down	7V	7V	14V	14V
Under voltage restart	7,5V	7,5V	15V	15V
Nominal output voltage	12,2V	24,2V	12,2V	24,2V
Output voltage adjust range	10-15V	20-30V	10-15V	20-30V
Output voltage tolerance	+/- 0,2V			
Output noise	2mV rms			
Cont. output current at nominal output voltage and 40°C	30A	15A	30A	17A
Maximum output current (10 s) at nominal output voltage	40A	25A	45A	25A
Short circuit output current	60A	40A	60A	40A
Cont. output power at 25°C	430W	430W	430W	480W
Cont. output power at 40°C	360W	360W	360W	400W
Efficiency	87%	88%	88%	89%
No load input current	< 80mA	< 100mA	< 100mA	< 80mA
Standby current	Less than 1mA			
Operating temperature range	-20 to +55°C (derate 3% per °C above 40°C)			
Humidity	Max. 95% non-condensing			
DC connection	Screw terminals			
Maximum cable cross-section	16 mm ² (AWG6)			
Weight	12V input and/or 12V output models: 1,8 kg (3 lb)		Other models: 1,6 kg (3.5 lb)	
Dimensions h x w x d	130 x 186 x 80 mm (5.1 x 7.3 x 3.2 inch)			
Standards: Safety	EN 60950			
Emission	EN 61000-6-3, EN 55014-1			
Immunity	EN 61000-6-2, EN 61000-6-1, EN 55014-2			
Automotive Directive	ECE R10-5			

1) If set to nominal or lower than nominal, the output voltage will remain stable within the specified input voltage range (buck-boost function). If the output voltage is set higher than nominal by a certain percentage, the minimum input voltage at which the output voltage remains stable (does not decrease) increases by the same percentage.

Note 1: The VictronConnect App will not display current in or current out.
Note 2: The Orion-Tr Smart is not equipped with a VE.Direct port.

Orlon-Tr Smart DC-DC charger Isolated



Orlon-Tr Smart 12/12-30



Orlon-Tr Smart 12/12-30



Bluetooth Smart enabled

Any Bluetooth enabled smart phone, tablet or other device can be used to monitor, to change settings and to update the charger when new software features become available.

Fully programmable

- Battery charge algorithm (configurable) or fixed output.
- Smart alternator compatibility: engine running detection mechanism.

Adaptive 3-stage charge algorithm: bulk – absorption – float

- For lead acid batteries it is important that during shallow discharges the absorption time is kept short in order to prevent overcharging of the battery. After a deep discharge the absorption time is automatically increased to make sure that the battery is completely recharged.
- For lithium batteries absorption time is fixed, default 2 hours.
- Alternatively, a fixed output voltage can be chosen.

Suitable for use in vehicles with a smart alternator (Euro 5 and Euro 6 engines)

The built-in engine shutdown detection will stop the converter when the engine is not running. This prevents unwanted discharge of the starter battery (see manual for details).

Remote on-off

A remote on/off switch or relay contact can be connected to a two-pole connector. Alternatively, the H terminal (right) of the two-pole connector can be switched to battery plus, or the L terminal (left) of the two pole connector can be switched to battery minus (or the chassis of a vehicle, for example).

All models are short circuit proof and can be paralleled to increase output current

An unlimited number of units can be connected in parallel.

High temperature protected

The output current will reduce at high ambient temperature.

IP43 protection

When installed with the screw terminals oriented downwards.

Screw terminals

No special tools needed for installation.

Input fuse (not replaceable)

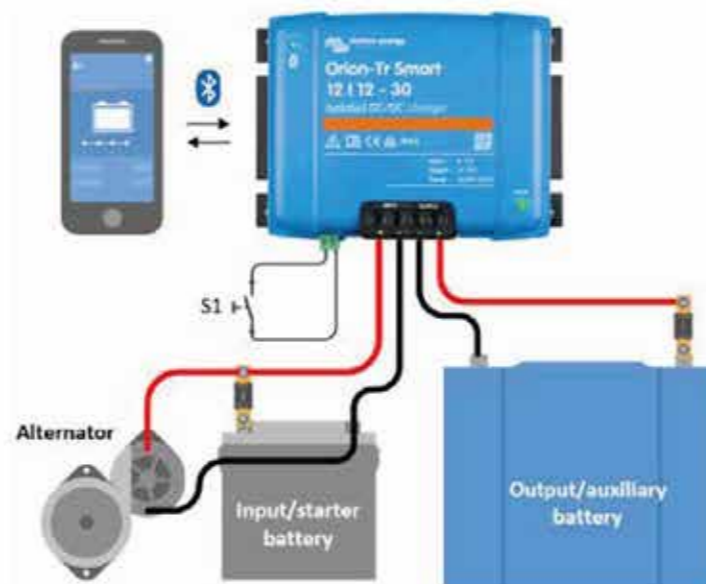

Orlon-Tr Smart Chargers Isolated 220 - 280 Watt	12/12-18 (220W)	12/24-10 (240W)	24/12-20 (240W)	24/24-12 (280W)
Input voltage range (1)	8-17V	8-17V	16-35V	16-35V
Under voltage shut down	7V	7V	14V	14V
Under voltage restart	7,5V	7,5V	15V	15V
Nominal output voltage	12,2V	24,2V	12,2V	24,2V
Output voltage adjust range	10-15V	20-30V	10-15V	20-30V
Output voltage tolerance	+/- 0,2V			
Output noise	2mV rms			
Cont. output current at nominal output voltage and 40°C	18A	10A	20A	12A
Maximum output current (10 s) at nominal output voltage	25A	15A	25A	15A
Short circuit output current	40A	25A	50A	30A
Cont. output power at 25°C	280W	280W	300W	320W
Cont. output power at 40°C	220W	240W	240W	280W
Efficiency	87%	88%	88%	89%
No load input current	< 80mA	< 100mA	< 100mA	< 80mA
Standby current	Less than 1mA			
Galvanic isolation	200V dc between input, output and case			
Operating temperature range	-20 to +55°C (derate 3% per °C above 40°C)			
Humidity	Max. 95% non-condensing			
DC connection	Screw terminals			
Maximum cable cross-section	16 mm ² AWG6			
Weight	1,3 kg (3 lb)			
Dimensions hxxwxd	130 x 186 x 70 mm (5.1 x 7.3 x 2.8 inch)			
Standards: Safety	EN 60950			
Emission	EN 61000-6-3, EN 55014-1			
Immunity	EN 61000-6-2, EN 61000-6-1, EN 55014-2			
Automotive Directive	ECE R10-5			

Orlon-Tr Smart Chargers Isolated 360 - 400 Watt	12/12-30 (360W)	12/24-15 (360W)	24/12-30 (360W)	24/24-17 (400W)
Input voltage range (1)	10-17V	10-17V	20-35V	20-35V
Under voltage shut down	7V	7V	14V	14V
Under voltage restart	7,5V	7,5V	15V	15V
Nominal output voltage	12,2V	24,2V	12,2V	24,2V
Output voltage adjust range	10-15V	20-30V	10-15V	20-30V
Output voltage tolerance	+/- 0,2V			
Output noise	2mV rms			
Cont. output current at nominal output voltage and 40°C	30A	15A	30A	17A
Maximum output current (10 s) at nominal output voltage minus 20%	40A	25A	45A	25A
Short circuit output current	60A	40A	60A	40A
Cont. output power at 25°C	430W	430W	430W	480W
Cont. output power at 40°C	360W	360W	360W	400W
Efficiency	87%	88%	88%	89%
No load input current	< 80mA	< 100mA	< 100mA	< 80mA
Standby current	Less than 1mA			
Galvanic isolation	200V dc between input, output and case			
Operating temperature range	-20 to +55°C (derate 3% per °C above 40°C)			
Humidity	Max. 95% non-condensing			
DC connection	Screw terminals			
Maximum cable cross-section	16 mm ² (AWG6)			
Weight	12V input and/or 12V output models: 1,8 kg (3 lb)		Other models: 1,6 kg (3.5 lb)	
Dimensions hxxwxd	12V input and/or 12V output models: 130 x 186 x 80 mm (5.1 x 7.3 x 3.2 inch) Other models: 130 x 186 x 70 mm (5.1 x 7.3 x 2.8 inch)			
Standards: Safety	EN 60950			
Emission	EN 61000-6-3, EN 55014-1			
Immunity	EN 61000-6-2, EN 61000-6-1, EN 55014-2			
Automotive Directive	ECE R10-5			

1) If set to nominal or lower than nominal, the output voltage will remain stable within the specified input voltage range (buck-boost function). If the output voltage is set higher than nominal by a certain percentage, the minimum input voltage at which the output voltage remains stable (does not decrease) increases by the same percentage.
 Note 1) The VictronConnect App will not display current in or current out.
 Note 2) The Orlon-Tr Smart is not equipped with a VE.Direct port.

Orion-Tr DC-DC converters Isolated: 100 / 250 / 400 Watt

- [Application Examples](#)
- [Motorhomes](#)
- [Ambulances](#)
- [Coffee cart Espresso Systems](#)
- [Accessories](#)
- [Tools](#)
- [Technical information](#)



Orion-Tr 24/12-20 (240W)



Orion-Tr 24/12-20 (240W)

Remote on-off
The remote on-off eliminates the need for a high current switch in the input wiring. The remote on-off can be operated with a low power switch or by for example the engine run/stop switch (see manual).

Adjustable output voltage: can also be used as a battery charger
For example to charge a 12 Volt starter or accessory battery in an otherwise 24V system.

All models are short circuit proof and can be paralleled to increase output current
An unlimited number of units can be connected in parallel.

High temperature protected
The output current will reduce at high ambient temperature.

IP43 protection
When installed with the screw terminals oriented downwards.

Screw terminals
No special tools needed for installation.

Input fuse (not replaceable)
On 12V and 24V input models only.

Isolated converters 110 - 120W	Orion-Tr 12/12-9 (110W)	Orion-Tr 12/24-5 (120W)	Orion-Tr 24/12-9 (110W)	Orion-Tr 24/24-5 (120W)	Orion-Tr 24/48-2,5 (120W)	Orion-Tr 48/12-9 (110W)	Orion-Tr 48/24-5 (120W)	Orion-Tr 48/48-2,5 (120W)
Input voltage range (1)	8-17V	8-17V	16-35V	16-35V	16-35V	32-70V	32-70V	32-70V
Under voltage shut down	7V	7V	14V	14V	14V	28V	28V	28V
Under voltage restart	7,5V	7,5V	15V	15V	15V	30V	30V	30V
Nominal output voltage	12,2V	24,2V	12,2V	24,2V	48,2V	12,2V	24,2V	48,2V
Output voltage adjust range	10-15V	20-30V	10-15V	20-30V	40-60V	10-15V	20-30V	40-60V
Output voltage tolerance	+/- 0,2V							
Output noise	2mV rms							
Cont. output current at nominal output voltage and 25°C	9A	5A	9A	5A	2,5A	9A	5A	2,5A
Maximum output current (10 s) at nominal output voltage	12,5A	6,3A	12,5A	6,3A	3,0A	12,5A	6,3A	3,0A
Short circuit output current	32A	23A	39A	30A	19A	27A	25A	17A
Cont. output power at 25°C	110W	120W	110W	120W	120W	110W	120W	120W
Cont. output power at 40°C	85W	110W	85W	115W	115W	85W	100W	85W
Efficiency	87%	88%	85%	87%	88%	87%	86%	89%
Off load current	< 50mA	< 80mA	< 40mA	< 60 mA	< 120mA	< 50mA	< 60mA	< 80mA
Galvanic Isolation	200V dc between input, output and case							
Operating temperature range	-20 to +55°C (derate 3% per °C above 40°C)							
Humidity	Max. 95% non-condensing							
DC connection	Screw terminals							
Maximum cable cross-section	6 mm ² AWG10							
Weight	0,42 kg (1 lb)							
Dimensions h x w x d	100 x 113 x 47 mm (4,0 x 4,5 x 1,9 inch)							
Standards: Safety	EN 60950							
Emission	EN 61000-6-3, EN 55014-1							
Immunity	EN 61000-6-2, EN 61000-6-1, EN 55014-2							
Automotive Directive	ECE R10-5							

1) If set to nominal or lower than nominal, the output voltage will remain stable within the specified input voltage range (buck-boost function). If the output voltage is set higher than nominal by a certain percentage, the minimum input voltage at which the output voltage remains stable (does not decrease) increases by the same percentage.

Isolated converters 220 - 280 Watt	Orion-Tr 12/12-18 (220W)	Orion-Tr 12/24-10 (240W)	Orion-Tr 24/12-20 (240W)	Orion-Tr 24/24-12 (280W)	Orion-Tr 24/48-6 (280W)	Orion-Tr 48/12-20 (240W)	Orion-Tr 48/24-12 (280W)	Orion-Tr 48/48-6 (280W)
Input voltage range (1)	8-17V	8-17V	16-35V	16-35V	16-35V	32-70V	32-70V	32-70V
Under voltage shut down	7V	7V	14V	14V	14V	28V	28V	28V
Under voltage restart	7,5V	7,5V	15V	15V	15V	30V	30V	30V
Nominal output voltage	12,2V	24,2V	12,2V	24,2V	48,2V	12,2V	24,2V	48,2V
Output voltage adjust range	10-15V	20-30V	10-15V	20-30V	40-60V	10-15V	20-30V	40-60V
Output voltage tolerance	+/- 0,2V							
Output noise	2mV rms							
Cont. output current at nominal output voltage and 40°C	18A	10A	20A	12A	6A	20A	12A	6A
Maximum output current (10 s) at nominal output voltage	25A	15A	25A	15A	8A	25A	15A	8A
Short circuit output current	40A	25A	50A	30A	25A	50A	30A	25A
Cont. output power at 25°C	280W	280W	300W	320W	320W	280W	320W	320W
Cont. output power at 40°C	220W	240W	240W	280W	280W	240W	280W	280W
Efficiency	87%	88%	88%	89%	89%	87%	89%	89%
Off load current	< 80mA	< 100mA	< 100mA	< 80mA	< 120 mA	< 80mA	< 80mA	< 80mA
Galvanic Isolation	200V dc between input, output and case							
Operating temperature range	-20 to +55°C (derate 3% per °C above 40°C)							
Humidity	Max. 95% non-condensing							
DC connection	Screw terminals							
Maximum cable cross-section	16 mm ² AWG6							
Weight	1,3 kg (3 lb)							
Dimensions h x w x d	130 x 186 x 70 mm (5,1 x 7,3 x 2,8 inch)							
Standards: Safety	EN 60950							
Emission	EN 61000-6-3, EN 55014-1							
Immunity	EN 61000-6-2, EN 61000-6-1, EN 55014-2							
Automotive Directive	ECE R10-5							

Isolated converters 360 - 400 Watt	Orion-Tr 12/12-30 (360W)	Orion-Tr 12/24-15 (360W)	Orion-Tr 24/12-30 (360W)	Orion-Tr 24/24-17 (400W)	Orion-Tr 24/48-8,5 (400W)	Orion-Tr 48/12-30 (360W)	Orion-Tr 48/24-16 (380W)	Orion-Tr 48/48-8 (380W)
Input voltage range (1)	10-17V	10-17V	20-35V	20-35V	20-35V	40-70V	40-70V	40-70V
Under voltage shut down	7V	7V	14V	14V	14V	28V	28V	28V
Under voltage restart	7,5V	7,5V	15V	15V	15V	30V	30V	30V
Nominal output voltage	12,2V	24,2V	12,2V	24,2V	48,2V	12,2V	24,2V	48,2V
Output voltage adjust range	10-15V	20-30V	10-15V	20-30V	40-60V	10-15V	20-30V	40-60V
Output voltage tolerance	+/- 0,2V							
Output noise	2mV rms							
Cont. output current at nominal output voltage and 40°C	30A	15A	30A	17A	8,5A	30A	16A	8A
Maximum output current (10 s) at nominal output voltage minus 20%	40A	25A	45A	25A	15A	40A	25A	15A
Short circuit output current	60A	40A	60A	40A	25A	60A	40A	25A
Cont. output power at 25°C	430W	430W	430W	480W	480W	430W	430W	430W
Cont. output power at 40°C	360W	360W	360W	400W	400W	360W	380W	380W
Efficiency	87%	88%	88%	89%	89%	87%	89%	89%
Off load current	< 80mA	< 100mA	< 100mA	< 80mA	< 120 mA	< 80mA	< 80mA	< 80mA
Galvanic Isolation	200V dc between input, output and case							
Operating temperature range	-20 to +55°C (derate 3% per °C above 40°C)							
Humidity	Max. 95% non-condensing							
DC connection	Screw terminals							
Maximum cable cross-section	16 mm ² (AWG6)							
Weight	12V input and/or 12V output models: 1,8 kg (3 lb)				Other models: 1,6 kg (3,5 lb)			
Dimensions h x w x d	12V input and/or 12V output models: 130 x 186 x 80 mm (5,1 x 7,3 x 3,2 inch)				Other models: 130 x 186 x 70 mm (5,1 x 7,3 x 2,8 inch)			
Standards: Safety	EN 60950							
Emission	EN 61000-6-3, EN 55014-1							
Immunity	EN 61000-6-2, EN 61000-6-1, EN 55014-2							
Automotive Directive	ECE R10-5							

1) If set to nominal or lower than nominal, the output voltage will remain stable within the specified input voltage range (buck-boost function). If the output voltage is set higher than nominal by a certain percentage, the minimum input voltage at which the output voltage remains stable (does not decrease) increases by the same percentage.

Orion-Tr DC-DC converters, low power

- High efficiency**
Using synchronous rectification, full load efficiency exceeds 95%.
- IP43 protection**
When installed with the screw terminals oriented downwards.
- Screw terminals**
No special tools needed for installation.



Orion-Tr 24/12-5 (60W)



Orion-Tr 24/12-10 (120W)

Non isolated converters	Orion-Tr 24/12-5	Orion-Tr 24/12-10	Orion-Tr 24/12-15	Orion-Tr 24/12-20
Input voltage range	18-35V	18-35V	18-35V	18-35V
Output voltage	12.7V	12.5V	12.5V	12.5V
Efficiency	95%	97%	97%	97%
Continuous output current	5A	10A	15A	20A
Max. Output current	7A	12A	20A	25A
Galvanic isolation	no	no	no	no
Off load current	< 20mA	< 45mA	< 35mA	< 35mA
Operating temperature range (derate 3% per °C above 40°C)	-20 to +55°C			
DC connection	Screw terminals			
Maximum cable cross-section	3,3 mm ² AWG12	6 mm ² AWG10	6 mm ² AWG10	6 mm ² AWG10
Weight kg (lbs)	0,09 (0.20)	0,2 (0.44)	0,25 (0.55)	0,25 (0.55)
Dimensions hxxwxd in mm (hxxwxd in inches)	53x51x27 (2.1x2x1.1)	73x94x37 (2.9x3.7x1.5)	73x94x45 (2.9x3.7x1.8)	73x94x45 (2.9x3.7x1.8)
Standards: Safety Emission Immunity Automotive Directive	EN 60950 EN 61000-6-3, EN 55014-1 EN 61000-6-2, EN 61000-6-1, EN 55014-2 ECE R10-4			

Orion DC-DC converters



Orion 24/12-25



Orion 24/12-40

Remote on-off connector
The remote on-off eliminates the need for a high current switch in the input wiring. The remote on-off can be operated with a low power switch or by the engine run/stop switch (see manual).

All models with adjustable output can also be used as a battery charger
For example to charge a 12 Volt starter or accessory battery in an otherwise 24V system.

All models with adjustable output can be paralleled to increase output current
Up to five units can be connected in parallel.

Easy to install
Delivery includes four insulated Fastons Female Crimp 6.3mm (eight Fastons in case of the Orion 24/12-40).

Low power models: please see Orion-Tr series



Orion 24/12-70



Orion 24/12-70 with binding posts

Non isolated converters	Orion 24/12-25	Orion 24/12-40	Orion 24/12-70	Orion 12/24-8	Orion 12/24-10	Orion 12/24-20
Input voltage range (V)	18-35	16-35	18-35	9-18	9-18	9-18
Under voltage shutdown (V)	14	14	14	8	8	8
Under voltage restart (V)	18	18	18	10	10	10
Output voltage adjustable with potentiometer	yes	no	yes	no	yes	yes
Output voltage (V)	Adjustable 10-15V F set 13.2V	13.2	Adjustable 10-15V F set 13.2V	24	Adjustable 20-30V F set 26.4V	Adjustable 20-30V F set 26.4V
Efficiency (%)	96	95	92	95	95	93
Suitable to buffer-charge a battery	yes	no	yes	no	yes	yes
Can be connected in parallel	yes	no	yes	no	yes	yes
Continuous output current (A)	25	40	70	8	10	20
Max. Output current (A)	35	55	85	20	20	30
Fan assisted cooling (temp. controlled)	no	yes	yes	no	no	yes
Galvanic isolation	no	no	no	no	no	no
Off load current	< 15mA	< 20mA	< 20mA	< 10mA	< 15mA	< 30mA
Remote on-off	yes	yes	yes	no	no	yes
Operating temperature range (derate 3% per °C above 40°C)	-20 to +55°C	-20 to +55°C	-20 to +55°C	-20 to +55°C	-20 to +55°C	-20 to +55°C
DC connection	Faston tabs 6.3 mm	Double Faston tabs 6.3 mm	M6 bolts	Faston tabs 6.3 mm	Faston tabs 6.3 mm	M6 bolts
Weight kg (lbs)	0,7 (1.55)	0,85 (1.9)	0,9 (2.0)	0,4 (0.8)	0,4 (0.9)	0,9 (2.0)
Dimensions hxxwxd in mm (hxxwxd in inches)	65x88x160 (2.6x3.5x6.3)	65x88x185 (2.6x3.5x7.3)	65x88x195 (2.6x3.5x7.7)	45x90x115 (1.8x3.5x4.5)	45x90x125 (1.8x3.5x4.9)	65x88x195 (2.6x3.5x7.7)
Standards: Safety Emission Immunity Automotive Directive	EN 60950 EN 61000-6-3, EN 55014-1 EN 61000-6-2, EN 61000-6-1, EN 55014-2 ECE R10-4					

Orion IP67 24/12 and 12/24 DC-DC converters

Completely encapsulated: waterproof, shockproof and ignition protected
Water, oil or dirt will not damage the Orion IP67 DC-DC Converter. The casing is made of cast aluminium and the electronics are moulded in resin.

Extra-long input and output cables
Thanks to the cables of 1.8 meters in length, intermediate cable interconnections to increase length even more will in most cases not be needed. This is an important reliability increasing feature in an area where IP67 protection grade is needed.

Wide input voltage range
With 15 to 40 Volts input range, a stable output is ensured during surges or sags due to other equipment connected to same battery.

Protected against overheating
It can be used in a hot environment such as a machine room.

Orion IP67	24/12-5	24/12-10	24/12-20	24/12-100	12/24-50
Input voltage range	15-40VDC			18-35VDC	10-15VDC
Under voltage shutdown	13V			15V	8V
Under voltage restart	14V			16V	9V
No load current at 24V	1mA	20mA	50mA	85mA	45mA
DC output voltage	12V +/- 3%	12V +/- 3%	12V +/- 3%	12V +/- 3%	24V +/- 3%
Maximum continuous output current	5A	10A	20A	100A	50A
Efficiency	93%	93%	95%	96%	96%
Ripple & Noise	75mVpp			150mVpp	
Operating temperature range (derate 3% per °C above 40°C)	-40 to +70°C (full rated output up to 40°C)				
Overload protection	Hiccup mode, recovers automatically after fault condition is removed				
Short circuit proof	Yes				
Protection against reverse polarity connection	With external fuse or circuit breaker (not included)				
ENCLOSURE					
Material & Colour	Aluminium (blue RAL 5012)				
Protection category	IP67				
DC connection	Two input and two output cables, length 1,8m			Bolts M6	
Cable cross section, input	0,8mm ² (18 AWG)	1,5mm ² (15 AWG)	2,6mm ² (13 AWG)	n.a.	n.a.
Cable cross section, output	0,8mm ² (18 AWG)	1,5mm ² (15 AWG)	2,6mm ² (13 AWG)	n.a.	n.a.
Weight (kg)	50 g	300 g	300 g	2,15 kg	3 kg
Dimensions (h x w x d in mm)	25 x 43 x 20	74 x 74 x 32	74 x 74 x 32	265 x 127 x 63	340 x 127 x 63
STANDARDS					
Safety	EN 60950				
Emission	EN 61000-6-3, EN 55014-1				
Immunity	EN 55014-2, EN 61000-6-1, EN 61000-6-2				
Automotive Directive	ECE R10-4				
Vibration	IEC 68-2-6: 10-150 Hz / 1.0 G				



Orion IP67 24/12-5
with 1,8 m cables



Orion IP67 24/12-10
Orion IP67 24/12-20



Orion IP67 24/12-100
Orion IP67 12/24-50



Cerbo GX and GX Touch 50



Cerbo GX

Cerbo GX: communication-centre

This communication-centre allows you to always have perfect control over your system from wherever you are and to maximise its performance. Simply access your system via our Victron Remote Management (VRM) portal, or access it directly, using the optional GX Touch 50 screen, a Multi-Functional Display (MFD) or our VictronConnect app thanks to its Bluetooth capability.

GX Touch 50: display accessory

The GX Touch 50 is a display accessory for the Cerbo GX. The five inch touch screen display gives an instant overview of your system and allows you to adjust settings. Simply connect the display to the Cerbo GX with just one cable. The GX Touch 50 has a waterproof design, has a top-mountable setup and is simple to install.

Remote Console on VRM

Monitor, control and configure the Cerbo GX remotely, over the internet. Just like if you were standing in front of the device, using Remote Console. The same functionality is also available on the local network LAN, or using the WiFi Access Point of the Cerbo GX.

Perfect monitoring & control

Instantly monitor the battery state of charge, power consumption, power harvest from PV, generator, and mains, or check tank levels and temperature measurements. Easily control the shore power input current limit, (auto)start/stop generator(s) or change any setting to optimise the system. Follow up on alerts, perform diagnostic checks and resolve complications remotely.

Simple mounting and configuration

The Cerbo GX is easily mountable and can also be mounted on a DIN-Rail using the DIN35 adapter small, (not included). Its separate touchscreen can be bolted on a dashboard, eliminating the need to create perfect cut-outs (like with the Color Control GX). Connection is easy via just one cable, taking away the hassle of having to bring many wires to the dashboard. The Bluetooth feature enables a quick connection and configuration via our VictronConnect app.



Accessories included with the Cerbo GX



GX Touch 50 (optional display for Cerbo GX)



Accessories included with the GX Touch 50

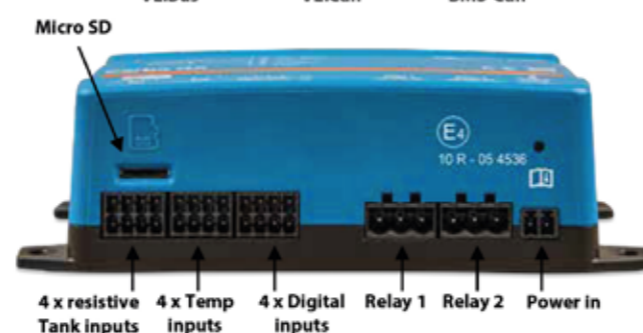
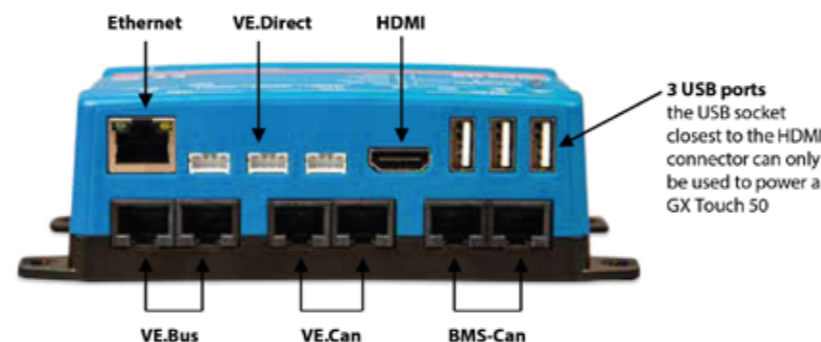

WiFi indicator LED

The Cerbo GX can connect to a WiFi Network

Bluetooth indicator LED

The Cerbo GX can be accessed directly via Bluetooth using the VictronConnect app



Cerbo GX	
Supply voltage	8 – 70V DC
Mounting	Wall or DIN rail (35mm) ¹⁾
Communication ports	
VE.Direct ports (always isolated)	3 ¹⁾
VE.Bus (always isolated)	2 paralleled RJ45 sockets
VE.Can	yes - non isolated
Other	
Outer dimensions (h x w x d)	78 x 154 x 48 mm
Operating temperature range	-20 to +50°C
Standards	
Safety	tbd
EMC	tbd
Automotive	tbd
GX Touch 50	
Mounting	With included mounting accessories
Display Resolution	800x480
Other	
Outer dimensions (h x w x d)	87 x 128 x 12.4 mm
Cable length	2 meter

- Notes**
- For more detailed information about the Cerbo GX and the GX Touch 50, please visit the Victron GX product range page at Victron live: www.victronenergy.com/live/victron-gx:start
 - DIN rail mounting requires additional accessory - DIN35 Adapter.
 - The listed maximum on the 'Performance' section in above table is the total connected VE.Direct devices such as MPPT Solar Charge controllers. Total means all directly connected devices plus the devices connected over USB. The limit is mostly bound by CPU processing power. Note that there is also a limit to the other type of devices of which often multiple are connected: PV inverters. Up to three or four three phase inverters can typically be monitored on a CCGX. Higher power CPU devices can monitor more.

Optional accessories



GX Touch 50 adapter for CCGX cut-out
This adapter is designed to easily replace the CCGX display with the newer GX Touch 50. Contents of the packaging are the metal bracket, the plastic bezel, and four mounting screws.



Temperature sensor for Quattro, MultiPlus and GX Device (such as the Cerbo GX)



DIN35 adapter small
DIN-Rail adapter to easily mount a device on a DIN-Rail. Suitable for the Cerbo GX.

Color Control GX



Color Control GX

The Color Control (CCGX) provides intuitive control and monitoring for all Victron power systems. The list of Victron products that can be connected is endless: Inverters, Multis, Quattros, MPPT solar chargers, BMV battery monitors, Lynx Ion + Shunt and more.

VRM Online Portal

Besides monitoring and controlling products locally on the CCGX itself, all readings are also forwarded to our free remote monitoring website: the VRM Online Portal. To get an impression, try the demo on <https://vrm.victronenergy.com>. See also the screenshots below.

Remote Console on VRM

Monitor, control and configure the CCGX remotely, over the internet. Just like standing in front of the device, everything can also be done remotely. The same functionality is also available on the local network, Remote Console on LAN.

Automatic genset start/stop

A highly customizable start/stop system. Use state of charge, voltage, load and other parameters. Define a special set of rules for quiet times, and optionally a monthly test run.

The heart of ESS – Energy Storage System

The CCGX is the Energy Manager in an ESS system. More information in the ESS manual: <https://www.victronenergy.com/live/ess:design-installation-manual>

Data logging

When connected to the internet, all data is sent to the VRM Portal. When there is no internet connection available, the CCGX will store the data internally, up to 48 hours. By inserting a micro SD-card or USB stick, more data can be stored. These files can then be uploaded to the VRM Portal, or offline converted with the VictronConnect app, for analysis.

Supported products

- Multis and Quattros, including split-phase and three-phase systems. Monitoring and control (on/off and current limiter). Changing configuration is possible (only remotely via the Internet, not without an internet connection).
- BlueSolar MPPT Solar Chargers with a VE.Direct port.
- BlueSolar MPPT 150/70 and the MPPT 150/85 with VE.Can port.
- SmartSolar MPPT 150/70 and the MPPT 150/100 with VE.Can port. When multiple BlueSolar MPPTs or SmartSolar MPPTs with VE.Can are used in parallel, all the information is combined as one. See also our blog-post about [synchronizing multiple MPPT 150/70 solar chargers](#).
- BMV-700 family can be connected directly to the VE.Direct ports on the CCGX. Use the VE.Direct Cable for this.
- BMV-600 family can be connected to the VE.Direct ports on the CCGX. Requires an accessory cable.
- Lynx Ion + Shunt
- Lynx Shunt VE.Can
- Skylla-I battery chargers
- NMEA2000 tank sensors
- A USB GPS can be connected to the USB port. Location and speed will be visible on the display, and the data is sent to the VRM Portal for tracking purposes. The map on VRM will show the latest position.
- Fronius PV Inverters

When more than two VE.Direct products must be connected, USB can be used.

Internet connection

The CCGX can be connected to internet with an Ethernet cable and via wifi. To connect via wifi, a wifi USB accessory is required. The CCGX has no internal cellular modem: there is no slot for a sim-card. Use an off-the-shelf GPRS or 3G router instead. See the [blog post about 3G routers](#).

Other highlights

- The CCGX can automatically update itself from the internet, when there is a new software version available.
- Multiple languages: English, Czech, German, Spanish, French, Italian, Dutch, Russian, Swedish, Turkish, Chinese, Arabic.
- Use the CCGX as a Modbus-TCP gateway to all connected Victron products. See our [Modbus-TCP FAQ](#) for more information.
- Powered by the Venus OS – embedded linux. <https://github.com/victronenergy/venus/wiki/sales-pitch>

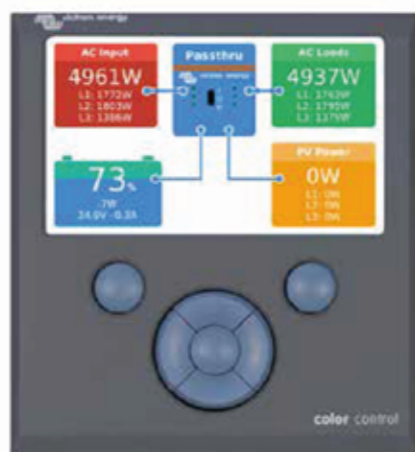

Color Control GX	
Power supply voltage range	8 – 70V DC
Current draw	12V DC 24V DC 48V DC
Display off	140mA 80mA 40mA
Display at minimum intensity	160mA 90mA 45mA
Display at maximum intensity	245mA 125mA 65mA
Potential free contact	3A / 30V DC / 250V AC (Normally open)
Communication ports	
VE.Direct	2 separate VE.Direct ports – isolated
VE.Can	2 paralleled RJ45 sockets – isolated
VE.Bus	2 paralleled RJ45 sockets – isolated
USB	2 USB Host ports – not isolated
Ethernet	10/100/1000MB RJ45 socket – isolated except shield
3rd party interfacing	
Modbus-TCP	Use Modbus-TCP to monitor and control all products connected to the Color Control GX
JSON	Use the VRM JSON API to retrieve data from the VRM Portal
Other	
Outer dimensions (h x w x d)	130 x 120 x 28mm
Operating temperature range	-20 to +50°C
Standards	
Safety	EN 60950-1:2005+A1:2009+A2:2013
EMC	EN 61000-6-3, EN 55014-1, EN 61000-6-2, EN 61000-6-1, EN 55014-2
Automotive	E4-10R-053535

Overview - Multi with PV Inverter on output



Mobile & boat overview



Genset control page



Main menu



Alarm notifications

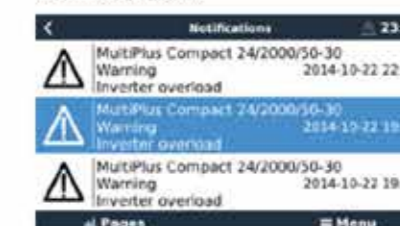

Tiles overview

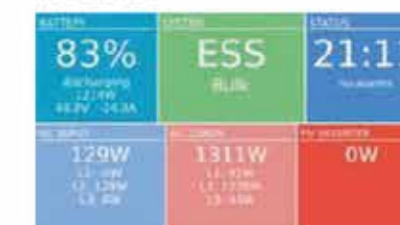

Color Control GX

VRM Portal - Dashboard



VRM Portal - Remote Console

Almere ESS-Grid-1000 OPzS

Device List 21:18

Fronius Symo 8.2-3-M	0W >
Grid meter	216W >
MultiPlus 48/5000/70-50	Bulk >
PV inverter on input 1	0W >
Notifications	>
Settings	>

Pages Menu

Almere ESS-Grid-1000 OPzS Remote Console

Realtime data

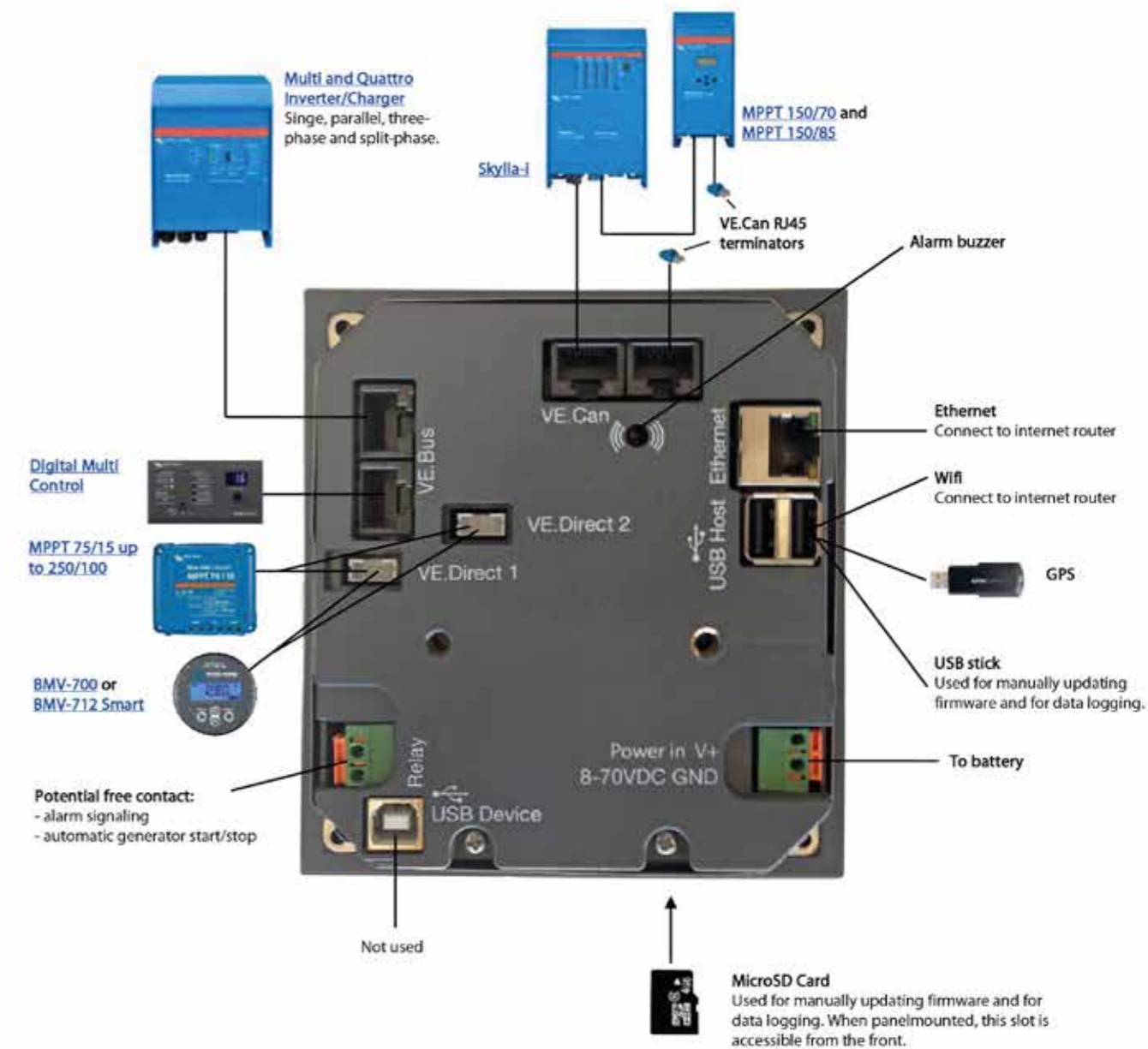

Venus GX



Venus GX



Venus GX with connectors



Venus GX front angle

Venus GX

The Venus GX provides intuitive control and monitoring for all Victron power systems. The list of Victron products that can be connected is endless: Inverters, Multis, Quattros, MPPT solar chargers, BMV battery monitors, Lynx Ion + Shunt and more.

VRM Online Portal

All readings are forwarded to our free remote monitoring website: the VRM Online Portal. To get an impression, try the demo on <https://vrm.victronenergy.com>. See also the screenshots below.

Remote Console on VRM

The way to access the device for setting up, as well as monitoring, is via Remote Console. Either via VRM, via the built-in WiFi Access Point, or on the local LAN/WiFi network.

Automatic genset start/stop

A highly customizable start/stop system. Use state of charge, voltage, load and other parameters. Define a special set of rules for quiet times, and optionally a monthly test run.

The heart of ESS – Energy Storage System

The Venus GX is the Energy Manager in an ESS system. More information in the ESS manual: <https://www.victronenergy.com/live/ess/design-installation-manual>

Data logging

When connected to the internet, all data is sent to the VRM Portal. When there is no internet connection available, the Venus GX will store the data internally, up to 48 hours. By inserting a micro SD-card or USB stick, more data can be stored. These files can then be uploaded to the VRM Portal, or offline converted with the VictronConnect app, for analysis.

Supported products

- Multis and Quattros, including split-phase and three-phase systems. Monitoring and control (on/off and current limiter). Changing configuration is possible (only remotely via the internet, not without an internet connection).
- EasySolar 1600VA
- BlueSolar MPPT Solar Chargers with a VE.Direct port.
- BlueSolar MPPT 150/70 and the MPPT 150/85 with VE.Can port.
- SmartSolar MPPT 150/70 and the MPPT 150/100 with VE.Can port. When multiple BlueSolar MPPTs or SmartSolar MPPTs with VE.Can are used in parallel, all the information is combined as one. See also our blog-post about [synchronizing multiple MPPT 150/70 solar chargers](#).
- BMV-700 family can be connected directly to the VE.Direct ports on the Venus GX. Use the VE.Direct Cable for this.
- BMV-600 family can be connected to the VE.Direct ports on the Venus GX. Requires an accessory cable.
- Lynx Ion + Shunt
- Lynx Ion BMS
- Lynx Shunt VE.Can
- Skylla-I battery chargers
- NMEA2000 tank sensors
- A USB GPS can be connected to the USB port. The data is sent to the VRM Portal for tracking purposes. The map on VRM will show the latest position.
- Fronius PV Inverters

When more than two VE.Direct products must be connected, USB can be used.

Internet connection

The Venus GX can be connected to internet with an Ethernet cable and via Wi-Fi. The Venus GX has no internal cellular modem: there is no slot for a sim-card. Use an off-the-shelf GPRS or 3G router instead. See the [blog post about 3G routers](#).

Tank level inputs

The tank level inputs are resistive: connect them to a resistive tank sender. Such tank senders are not supplied by Victron. The tank level ports can each be configured to work with either European tank senders (0 - 180 Ohm), or US (240 - 30 Ohm).

Other highlights

- The Venus GX can automatically update itself from the internet, when there is a new software version available.
- Multiple languages: English, Czech, German, Spanish, French, Italian, Dutch, Russian, Swedish, Turkish, Chinese, Arabic.
- Use the Venus GX as a Modbus-TCP gateway to all connected Victron products. See our [Modbus-TCP FAQ](#) for more information.
- Powered by the Venus OS – embedded linux. <https://github.com/victronenergy/venus/wiki/sales-pitch>

Venus GX	
Power supply voltage range	8 – 70V DC
Current Draw	210 mA @ 12V 110 mA @ 24V 60 mA @ 48V
Communication ports	
VE.Direct	2 separate VE.Direct ports – isolated
VE.Can	2 paralleled RJ45 sockets – isolated
CAN	2 nd CAN interface – non isolated
VE.Bus	2 paralleled RJ45 sockets – isolated
USB	2 USB Host ports – not isolated
Ethernet	10/100/1000MB RJ45 socket – isolated except shield
WiFi Access Point	Use to connect to Remote Console
WiFi Client	Connect the Venus GX to an existing WiFi network
IO	
Potential free contact	NO/COM/NC – 6 A 250 VAC/30 VDC
Tank level inputs	3 x Configurable for European (0 - 180 Ohm) or US (240 - 30 Ohm)
Temperature level inputs	2 x Requires ASS000001000.
3rd party interfacing	
Modbus-TCP	Use Modbus-TCP to monitor and control all products connected to the Venus GX
JSON	Use the VRM JSON API to retrieve data from the VRM Portal
Other	
Outer dimensions (h x w x d)	45 x 143 x 96
Operating temperature range	-20 to +50°C
Standards	
Safety	EN 60950-1:2005+A1:2009+A2:2013
EMC	EN 61000-6-3, EN 55014-1, EN 61000-6-2, EN 61000-6-1, EN 55014-2
Automotive	in progress

[Application Examples](#)

[Motorhomes](#)

[Ambulances](#)

[Coffee cart Espresso](#)

[Systems](#)

[Accessories](#)

[Tools](#)

[Technical information](#)



Buck-Boost DC-DC converter

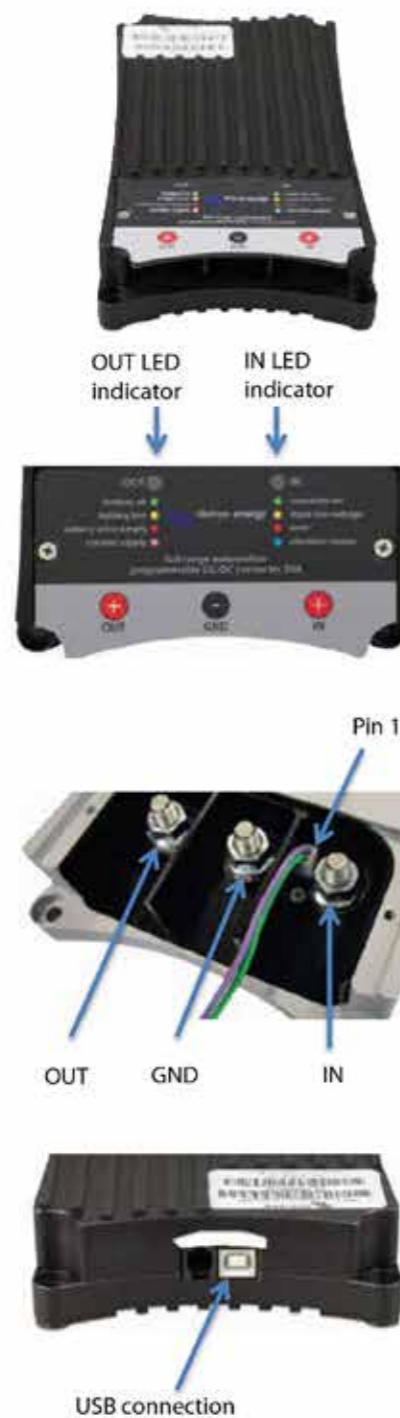

DC-DC Converter for charging a 12V or 24V service battery in vehicles with a smart alternator (regenerative braking, Euro 5 and Euro 6 engines)
 The Buck-Boost DC-DC Converter is a DC-DC Converter for charging a 12V or 24V service battery in vehicles with a smart alternator. The converter will charge the auxiliary battery with a pre-set charge voltage, eliminating high voltages (e.g. Mercedes: 15,4V) and low voltages.

'Engine running' detection system
 Deep discharge of the vehicle's starting battery is avoided by a built-in 'engine running' detection system.
 Instead of this detection system, the converter can also be activated by means of a programmable input (D+, CAN bus or (+)15 connection).

Fully programmable
 The converter can be fully programmed by means of a simple and user-friendly PC application. (USB type A male to USB type B male cable needed)

One product for 12V, 24V and 12/24V systems
 The converter can be programmed to charge a 12V or a 24V auxiliary battery from either a 12V or a 24V alternator and starter battery.

Charge current and input current limiter
 The output current is determined by the following factors:

- The maximum charge current setting.
- The maximum input current setting.
- The maximum operating temperature limit of the converter.

Input status indication (LED)
 Green: converter on.
 Yellow: input voltage below threshold, converter off.
 Red: over temperature, converter off.
 Blue, quick flash: engine running, converter will start after preset delay.
 Blue, slow flash: the converter is OFF and activation is blocked due to low input voltage.

Output status indication (LED)
 Green: converter off, battery voltage normal.
 Yellow: converter off, battery voltage low.
 Red: converter off, battery discharged or not connected.
 Purple: converter on.

Buck-Boost DC-DC Converter	25A	50A	100A
Input voltage range		10-30V	
Under voltage threshold		10V	
Output voltage range		10-30V	
Maximum charge current	12V: 25A 24V: 15A	12V: 50A 24V: 25A	12V: 100A 24V: 50A
Power consumption			
Converter off, LEDs off (power save mode)	7 mA		
On/off input (pin 1, purple wire)			
'On' threshold voltage	> 2V		
Maximum input voltage	30V		
Output pin 1 and pin 2			
Output voltage if activated	$V_{\text{output}} = V_{\text{in}}$		
Maximum current (per pin)	$I_{\text{output}} = 1A$		
GENERAL			
Operating temperature range	-25 +60°C		
Ambient temperature	Max current: up to 60°C		
Weight	0,6kg	1,4kg	4,1kg
Dimensions	165 x 120 x 30mm	213 x 120 x 30mm	288 x 162 x 95mm

Smart BatteryProtect 65A/100A/220A



Protects the battery against excessive discharge and can be used as a system on/off switch
 The Smart BatteryProtect disconnects the battery from non-essential loads before it is completely discharged (which would damage the battery) or before it has insufficient power left to crank the engine.
 The on/off input can be used as a system on/off switch.

12/24V auto ranging
 The Smart BatteryProtect automatically detects system voltage one time only.

Bluetooth: programming made easy
 When using Bluetooth to program the Smart BatteryProtect any required engage/disengage levels can be set. Alternatively, one of nine predefined engage/disengage levels can be set with the programming pin (see manual). If required, Bluetooth can be disabled.

A special setting for Li-Ion batteries
 In this mode the BatteryProtect can be controlled by the VE.Bus BMS.
Note: the BatteryProtect can also be used as a charge interrupter in between a battery charger and a Li-ion battery. See connection diagram in the manual.

Ultra-low current consumption
 This is important in case of Li-ion batteries, especially after low voltage shutdown.
 Please see our Li-ion battery datasheet and the VE.Bus BMS manual for more information.

Over voltage protection
 To prevent damage to sensitive loads due to over voltage, the load is disconnected whenever the DC voltage exceeds 16.3V respectively 32.6V.

Ignition proof
 No relays but MOSFET switches, and therefore no sparks.

Delayed alarm output
 The alarm output is activated if the battery voltage drops below the preset disconnect level during more than 12 seconds. Starting the engine will therefore not activate the alarm. The alarm output is a short circuit proof open collector output to the negative (minus) rail, max. current 50 mA. The alarm output is typically used to activate a buzzer, LED or relay.

Delayed load disconnect and delayed reconnect
 The load will be disconnected 90 seconds after the battery voltage drops below the preset level. If the battery voltage increases again to the connect threshold within this time period (after the engine has been started for example), the load will not be disconnected.
 The load will be reconnected 30 seconds after the battery voltage has increased to more than the preset reconnect voltage.

Smart BatteryProtect	Smart BP-65	Smart BP-100	Smart BP-220
Maximum continuous load current*	65A	100A	220A
Peak current (during 30 seconds)	250A	600A	600A
Operating voltage range	6-35V		
Current consumption	BLE On BLE Off	When on: 1,4 mA When off or low voltage shutdown: 0,9 mA	When on: 1,2 mA When off or low voltage shutdown: 0,7 mA
Alarm output delay	12 seconds		
Maximum load on alarm output	50 mA (short circuit proof)		
Load disconnect delay	90 seconds (immediate if triggered by the VE.Bus BMS)		
Load reconnect delay	30 seconds		
Default thresholds	Disengage: 10,5V or 21V Engage: 12V or 24V		
Operating temperature range	Full load: -40°C to +40°C (up to 60% of nominal load at 50°C)		
IP rating	Electronics: IP67 (potted) Connections: IP00		
Connection	M6	M8	M8
Weight	0,2 kg 0,5 lbs	0,5 kg 0,6 lbs	0,8 kg 1,8 lbs
Dimensions (h x w x d)	40 x 48 x 106 mm	59 x 42 x 115 mm	62 x 123 x 120 mm
	1,6 x 1,9 x 4,2 inch	2,4 x 1,7 x 4,6 inch	2,5 x 4,9 x 4,8 inch

* The BatteryProtect is not designed for reverse currents from charging sources

Connector with preassembled DC minus cable (included)

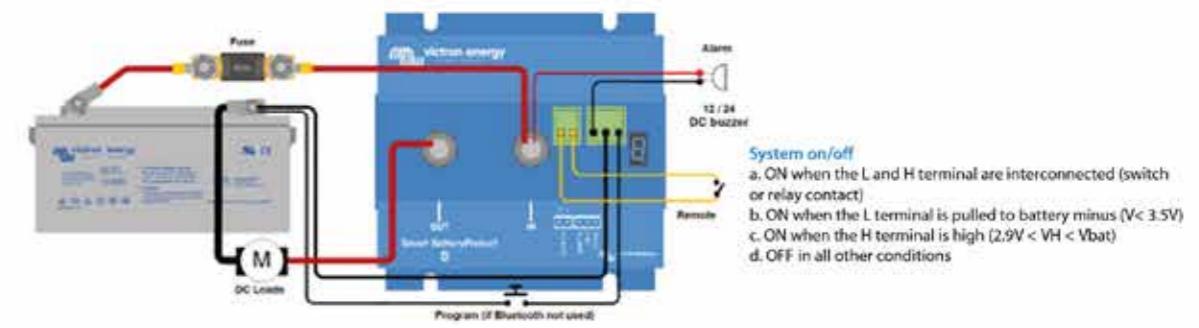

Cyrix-ct 12/24V 120A and 230A

[Application Examples](#)

[Motorhomes](#)

[Ambulances](#)

[Coffee cart Espresso](#)

[Systems](#)

[Accessories](#)

[Tools](#)

[Technical information](#)



Cyrix-ct 12/24-120



LED status indicator
Cyrix-ct 12/24-230



Control cable for
Cyrix-ct 12/24-230
Length: 1 m

Intelligent battery monitoring to prevent unwanted switching

Some battery combiners (also called voltage controlled relay, or split charge relay) will disconnect a battery in case of a short but high amperage load. A battery combiner also may fail to connect a large but discharged battery bank because the DC voltage immediately drops below the disengage value once the batteries are connected. The software of the Cyrix-ct 12/24 does more than simply connect and disconnect based on battery voltage and with a fixed time delay. The Cyrix-ct 12/24 looks at the general trend (voltage increasing or decreasing) and reverses a previous action only if the trend has reversed during a certain period of time. The time delay depends on the voltage deviation from the trend.

(for Battery Combiners with multiple engage/disengage profiles, please see the Cyrix-i 400)

Long bolts to allow connection of more than one power cable

Cyrix 12/24-120: 13 mm (M6) Cyrix 12/24-230: 16 mm (M8)

Protection against overheating (due to a long duration overload e.g.)

The Cyrix will disengage in case of excessive contact temperature, and reengage again after it has cooled down.

LED status indication (Cyrix 12/24 230 only)

LED on: engaged LED 10 s flash: disengaged
LED 2 s flash: connecting LED 2 s blink: disconnecting
LED 0,25 s blink: alarm (over temperature; voltage > 16 V; both batteries < 10 V; one battery < 2 V)
(multiply by two for 24 V)

12/24 V auto ranging

The Cyrix-ct 12/24 automatically detects system voltage.

No voltage loss

Cyrix battery combiners are an excellent replacement for diode isolators. The main feature is that there is virtually no voltage loss so that the output voltage of alternators or battery chargers does not need to be increased.

Prioritising the starter battery

In a typical setup the alternator is directly connected to the starter battery. The accessory battery, and possibly also a bow thruster and other batteries are each connected to the starter battery with Cyrix battery combiners. When a Cyrix senses that the starter battery has reached the connect voltage it will engage, to allow for parallel charging of the other batteries.

Bidirectional voltage sensing and power supply from both batteries

The Cyrix senses the voltage of both connected batteries. It will therefore also engage if for example the accessory battery is being charged by a battery charger.

The Cyrix-ct 12/24 has a dual power supply. It will therefore also close if the voltage on one battery is too low to operate the Cyrix.

In order to prevent unexpected operation during installation or when one battery has been disconnected, the Cyrix-ct 12/24 will not close if the voltage on one of the two battery connections is lower than 2 V (12 V battery) or 4 V (24 V battery).

Parallel connection in case of emergency (Start Assist)

The Cyrix can also be engaged with a push button (Cyrix remains engaged during 30 seconds) or a switch to connect batteries in parallel manually.

This is especially useful in case of emergency when the starter battery is discharged or damaged.

Cyrix Battery Combiner	Cyrix-ct 12/24-120	Cyrix-ct 12/24-230
LED status indication	No	Yes
Continuous current	120 A	230 A
Cranking rating (5 seconds)	180 A	500 A
Connect voltage	From 13 V to 13,8 V and 26 to 27,6 V with intelligent trend detection	
Disconnect voltage	From 11 V to 12,8 V and 22 to 25,7 V with intelligent trend detection	
Current consumption when open	<4 mA	
Current consumption when closed	12 V : 220 mA 24 V : 120 mA	12 V : 320 mA 24 V : 180 mA
Start Assist	Yes (Cyrix remains engaged during 30 seconds)	
Control cable included (length 1 m)	No	Yes
Protection category	IP54	
Weight kg (lbs)	0,11 (0,24)	0,27 (0,6)
Dimensions h x w x d in mm (h x w x d in inches)	46 x 46 x 80 (1,8 x 1,8 x 3,2)	65 x 100 x 50 (2,6 x 4,0 x 2,0)

Connect (V)	Delay
V < 13 V	Remains open
13,0 V < V < 13,2 V	10 min
13,2 V < V < 13,4 V	5 min
13,4 V < V < 13,6 V	1 min
13,6 V < V < 13,8 V	4 sec

Disconnect (V)	Delay
V < 11 V	0 sec
11,0 V < V < 12,0 V	1 sec
12,0 V < V < 12,2 V	10 sec
12,2 V < V < 12,4 V	30 sec
12,4 V < V < 12,8 V	3 min
> 12,8 V	remains closed
> 16 V	over voltage disconnect

Approximate connect and disconnect delay
(multiply by two for a 24 V system)

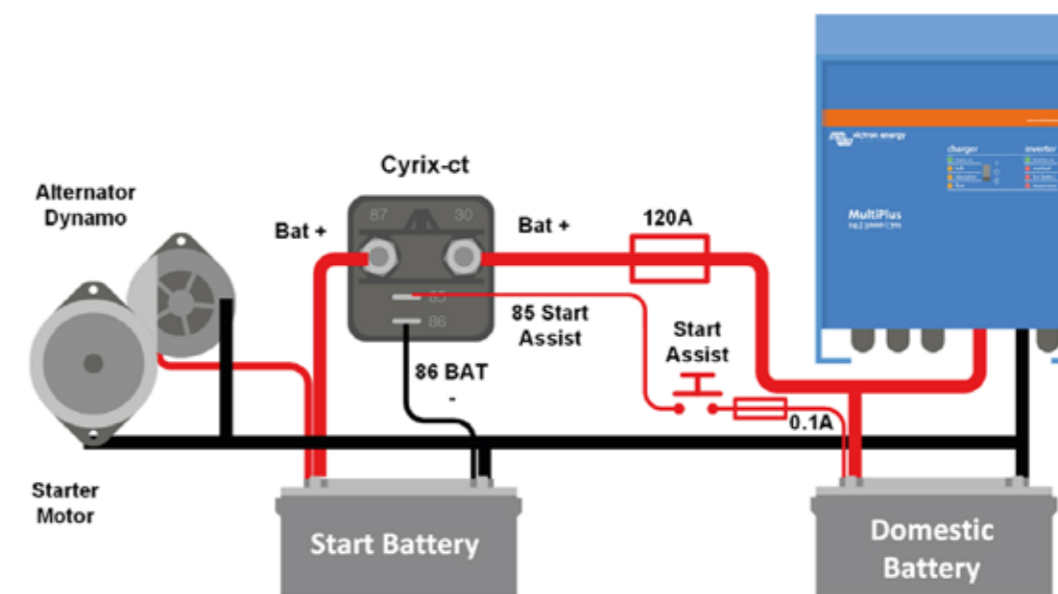

Cyrix-ct 12/24-120: connection diagram

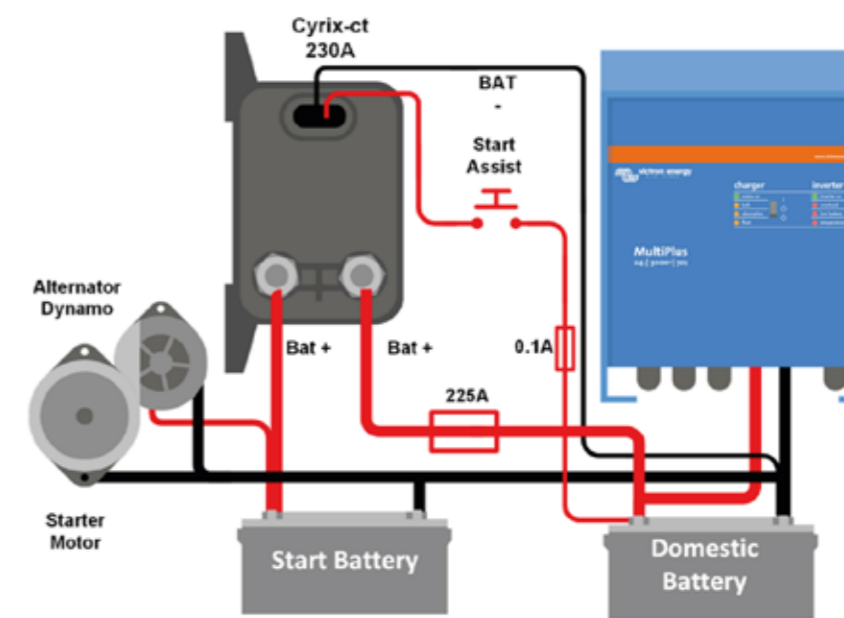

Cyrix-ct 12/24-230: connection diagram

Cyrix-ct 400A 12/24V and 24/48V



Cyrix-i 24/48 V 400 A

New: intelligent battery monitoring to prevent unwanted switching

Some battery combiners will disconnect a battery in case of a short but high amperage load. A battery combiner also may fail to connect a large but discharged battery bank because the DC voltage immediately drops below the disengage value once the batteries are connected.

The software of the Cyrix-i does more than simply connect and disconnect based on battery voltage and with a fixed time delay. The Cyrix-i looks at the general trend (voltage increasing or decreasing) and reverses a previous action only if the trend has reversed during a certain period of time. The time delay depends on the voltage deviation from the trend.

In addition, four switch timing profiles can be chosen (see back page).

12/24 V and 24/48 V auto ranging

The Cyrix-i automatically detects system voltage.

No voltage loss

Cyrix battery combiners are an excellent replacement for diode isolators. The main feature is that there is virtually no voltage loss so that the output voltage of alternators or battery chargers does not need to be increased.

Prioritizing the starter battery

In a typical setup the alternator is directly connected to the starter battery. The accessory battery, and possibly also a bow thruster and other batteries are each connected to the starter battery with Cyrix battery combiners. When a Cyrix senses that the starter battery has reached the connect voltage it will engage, to allow for parallel charging of the other batteries.

Bidirectional voltage sensing and power supply from both batteries

The Cyrix senses the voltage of both connected batteries. It will therefore also engage if for example the accessory battery is being charged by a battery charger.

The Cyrix-i has a dual power supply. It will therefore also close if the voltage on one battery is too low to operate the Cyrix.

In order to prevent unexpected operation during installation or when one battery has been disconnected, the Cyrix-i will not close if the voltage on one of the two battery connections is lower than 2 V (12 V battery), or 4 V (24 V battery) or 8 V (48 V battery).

Parallel connection in case of emergency

The Cyrix can also be engaged with a push button (Cyrix remains engaged during 30 s) or a switch to connect batteries in parallel manually.

This is especially useful in case of emergency when the starter battery is discharged or damaged.

Model	Cyrix-i 12/24-400 Cyrix-i 24/48-400
Continuous current	400A
Peak current	2000A during 1 second
Input voltage 12/24 V model	8-36 VDC
Input voltage 24/48 V model	16-72 VDC
Connect/disconnect profiles	See table
Over voltage disconnect	16 V / 32 / 64 V
Current consumption when open	4 mA
Emergency start	Yes, 30 s
Micro switch for remote monitoring	Yes
Status indication	Bicolour LED
Weight kg (lbs)	0,9 (2.0)
Dimensions h x w x d in mm (h x w x d in inches)	78 x 102 x 110 (3.1 x 4.0 x 4.4)

Profile 0			
Connect (V)*		Disconnect (V)*	
Less than 13 V	Remains open	More than 12,8 V	Remains closed
	Closes after		Opens after
13 V	10 min	12,8 V	10 min
13,2 V	5 min	12,4 V	5 min
13,4 V	3 min	12,2 V	1 min
13,6 V	1 min	12 V	4 sec
13,8 V	4 sec	Less than 11 V	Immediate

Profile 1			
Connect (V)*		Disconnect (V)*	
Less than 13,25 V	Remains open	More than 12,75 V	Remains closed
More than 13,25 V	Closes after 30 sec	From 10,5 V to 12,75 V	Opens after 2 min
		Less than 10,5 V	Immediate

Profile 2			
Connect (V)*		Disconnect (V)*	
Less than 13,2 V	Remains open	More than 12,8 V	Remains closed
More than 13,2 V	Closes after 6 sec	From 10,5 V to 12,8 V	Opens after 30 sec
		Less than 10,5 V	Immediate

Profile 3			
Connect (V)*		Disconnect (V)*	
Less than 13,25 V	Remains open	More than 13,5 V	Remains closed
	Closes after		Opens after
13 V	10 min	12,8 V	30 min
13,2 V	5 min	12,4 V	12 min
13,4 V	3 min	12,2 V	2 min
13,6 V	1 min	12 V	1 min
13,8 V	4 sec	Less than 10,5 V	Immediate

NOTES

- 1) After connecting 3 times, the minimum time to reconnect is 1 minute (to prevent 'rattling')
- 2) The Cyrix will not connect if the voltage on one of the battery connections is less than 2 V*, (to prevent unexpected switching during installation)
- 3) The Cyrix will always connect if the **start assist** is activated, as long as the voltage on one of the battery connections is sufficient to operate the Cyrix (approximately 10 V*)

* Multiply voltage x2 for 24 V systems and x4 for 48 V systems

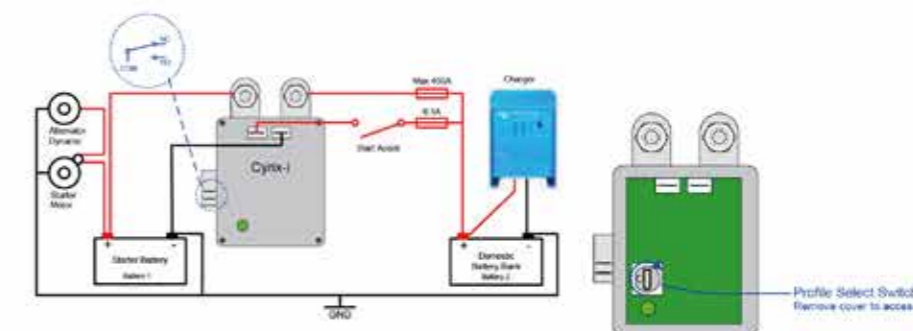

SmartShunt 500A / 1000A / 2000A



SmartShunt 500A



SmartShunt 1000A



SmartShunt 2000A



The SmartShunt is an all in one battery monitor, only without a display. Your phone acts as the display.

The SmartShunt connects via Bluetooth to the VictronConnect App on your phone (or tablet) and you can conveniently read out all monitored battery parameters, like state of charge, time to go, historical information and much more.

Alternatively, the SmartShunt can be connected and be read by a GX device. Connection to the SmartShunt is made via a VE.Direct cable.

The SmartShunt is a good alternative for a BMV battery monitor, especially for systems where battery monitoring is needed but less wiring and clutter is wanted.

The SmartShunt is equipped with Bluetooth, a VE.Direct port and a connection that can be used to monitor a second battery, for midpoint monitoring, or to connect a temperature sensor.

Differences compared to BMV712 Battery Monitor

- No programmable visual and audible alarm.
- No programmable relay.

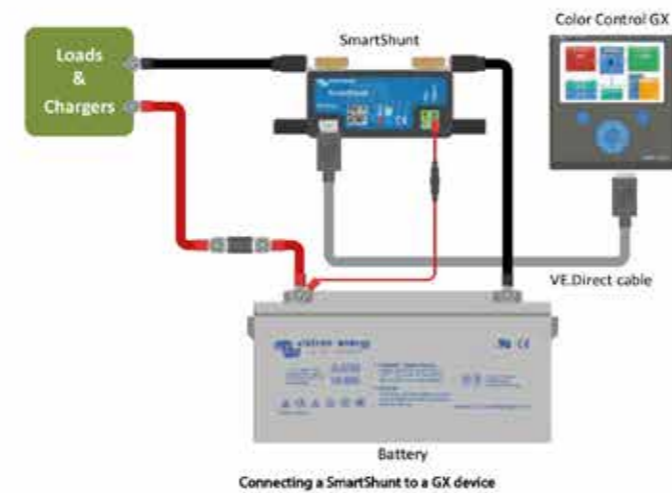
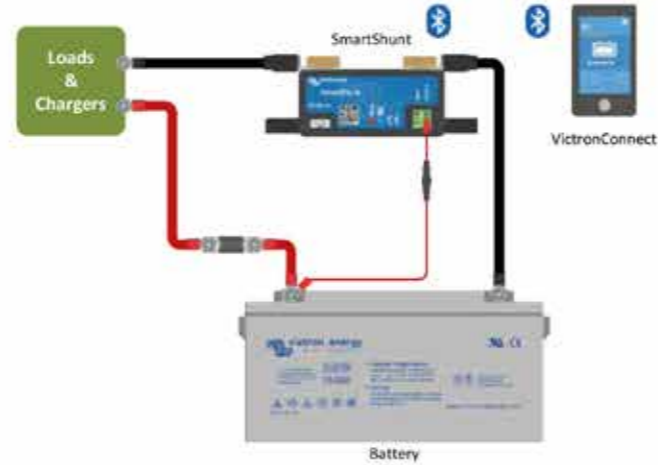

SmartShunt	500A / 1000A / 2000A
Supply voltage range	6.5 - 70 VDC
Current draw	< 1mA
Input voltage range, auxiliary battery	6.5 - 70 VDC
Battery capacity (Ah)	1 - 9999 Ah
Operating temperature range	-40 +50°C (-40 - 120°F)
Measures voltage of second battery, or temperature, or midpoint	Yes
Temperature measurement range	-20 +50°C
VE.Direct communication port	Yes
RESOLUTION & ACCURACY	
Current	± 0.01A
Voltage	± 0.01V
Amp hours	± 0.1 Ah
State of charge (0 - 100%)	± 0.1%
Time to go	± 1 min
Temperature (if optional temperature sensor connected)	± 1°C/°F (0 - 50°C or 30 - 120°F)
Accuracy of current measurement	± 0.4%
Offset	Less than 20 / 40 / 80 mA
Accuracy of voltage measurement	± 0.3%
INSTALLATION & DIMENSIONS	
Dimensions (h x w x d)	500A: 46 x 120 x 54 mm 1000A: 68 x 120 x 54 mm 2000A: 68 x 120 x 76 mm
Protection category	IP21
STANDARDS	
Safety	EN 60335-1
Emission / Immunity	EN-IEC 61000-6-1 EN-IEC 61000-6-2 EN-IEC 61000-6-3
Automotive	EN 50498
Cables (included)	Two cables with 1A fuse, for '+' connection and starter battery or midpoint connection
Temperature sensor	Optional (ASS000100000)

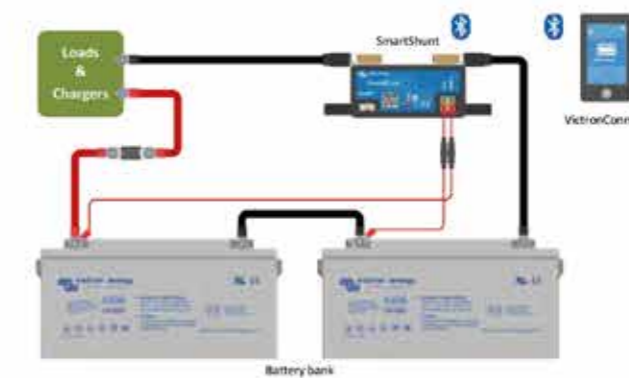
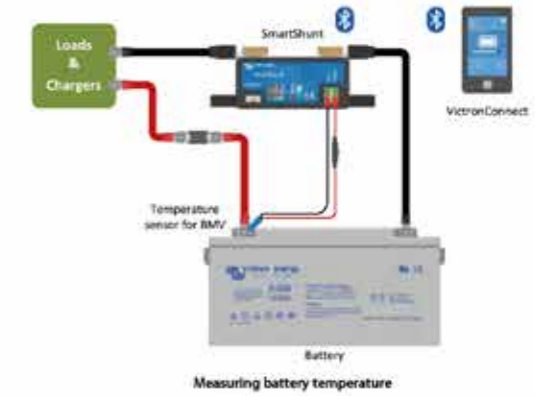
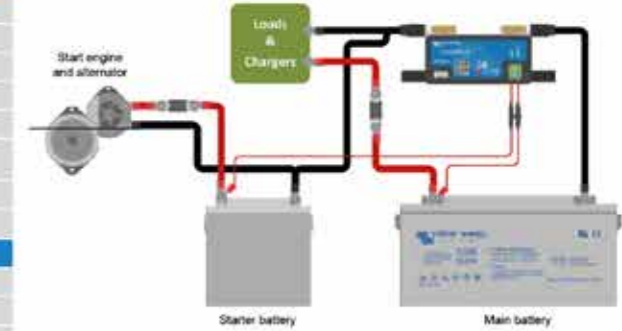

BMV-712 Smart: Bluetooth inside



BMV-712 Smart



BMV bezel square



BMV shunt 500A/50mV
With quick connect pcb



See the VictronConnect BMV app Discovery Sheet for more screenshots

Bluetooth inside

With Bluetooth built-in, the BMV Smart is ready for the Internet of Things (IoT) era. With Bluetooth being implemented in most other Victron Energy products, wireless communication between products will simplify system installation and enhance performance.

Download the Victron Bluetooth app

Use a smartphone or other Bluetooth enabled device to

- customize settings,
- monitor all important data on single screen,
- view historical data, and to
- update the software when new features become available.

Easy to install

All electrical connections are to the quick connect PCB on the current shunt. The shunt connects to the monitor with a standard RJ12 telephone cable. Included: RJ12 cable (10 m) and battery cable with fuse (2 m); no other components needed.

Also included are a separate front bezel for a square or round display appearance, a securing ring for rear mounting and screws for front mounting.

Midpoint voltage monitoring

One bad cell or one bad battery can destroy a large, expensive battery bank. When batteries are connected in series, a timely warning can be generated by measuring the midpoint voltage. Please see the BMV manual, section 5.2, for more information.

We recommend our **Battery Balancer** (BMS012201000) to maximize service life of series-connected lead-acid batteries.

Very low current draw from the battery

Current consumption: 0.7Ah per month (1mA) @12V and 0.6Ah per month (0.8mA) @ 24V. Especially Li-ion batteries have virtually no capacity left when discharged until low voltage shutdown. After shutdown due to low cell voltage, the capacity reserve of a Li-ion battery is approximately 1Ah per 100Ah battery capacity. The battery will be damaged if the remaining capacity reserve is drawn from the battery. A residual current of 10mA for example may damage a 200Ah battery if the system is left in discharged state during more than 8 days.

Bi-stable alarm relay

Prevents increased current draw in case of an alarm.

Other features

- Battery voltage, current, power, ampere-hours consumed and state of charge
- Remaining time at the current rate of discharge
- Programmable visual and audible alarm
- Programmable relay, to turn off non critical loads or to run a generator when needed
- 500 Amp quick connect shunt and connection kit
- Shunt selection capability up to 10,000 Amps
- VE.Direct communication port
- Stores a wide range of historical events, which can be used to evaluate usage patterns and battery health
- Wide input voltage range: 6.5 – 70V
- High current measurement resolution: 10 mA (0.01A)
- Additional input to measure voltage (of a second battery), temperature or midpoint voltage, and corresponding alarm and relay settings

Battery Monitor	BMV-712 Smart
Supply voltage range	6.5 - 70 VDC
Current draw, back light off	< 1mA
Input voltage range, auxiliary battery	6.5 - 70 VDC
Battery capacity (Ah)	1 - 9999 Ah
Operating temperature range	-40 +50°C (-40 - 120°F)
Measures voltage of second battery, or temperature, or midpoint	Yes
Temperature measurement range	-20 +50°C
VE.Direct communication port	Yes
Bistable relay	60V / 1A normally open (function can be inverted)
RESOLUTION & ACCURACY (with a 500 A shunt)	
Current	± 0.01A
Voltage	± 0.01V
Amp hours	± 0.1 Ah
State of charge (0 - 100%)	± 0.1%
Time to go	± 1 min
Temperature (0 - 50°C or 30 - 120°F)	± 1°C/°F
Accuracy of current measurement	± 0.4%
Accuracy of voltage measurement	± 0.3%
INSTALLATION & DIMENSIONS	
Installation	Flush mount
Front	63mm diameter
Front bezel	69 x 69mm (2.7 x 2.7 inch)
Body diameter and depth	52mm (2.0 inch) and 31mm (1.2 inch)
Protection category	IP55 (not intended for outdoor use)
STANDARDS	
Safety	EN 60335-1
Emission / Immunity	EN 55014-1 / EN 55014-2
Automotive	ECE R10-4 / EN 50498
ACCESSORIES	
Shunt (included)	500A / 50mV
Cables (included)	10 meter 6 core UTP with RJ12 connectors, and cable with fuse for '-' connection
Temperature sensor	Optional (A55000100000)



1000A/50mV, 2000A/50mV and 6000A/50mV shunt
The quick connect PCB on the standard 500A/50mV shunt can also be mounted on these shunts.



Interface cables
- VE.Direct cables to connect a BMV 712 to the Color Control (A5503053000)
- VE.Direct to USB interface (A5503053000) to connect several BMV 70x to a Color Control GX or to a computer.



Temperature sensor



Battery Balancer (BMS012201000)
The Battery Balancer equalizes the state of charge of two series connected 12V batteries, or of several parallel strings of series connected batteries.
When the charge voltage of a 24V battery system increases to more than 27V, the Battery Balancer will turn on and compare the voltage over the two series connected batteries. The Battery Balancer will draw a current of up to 1A from the battery (or parallel connected batteries) with the highest voltage. The resulting charge current differential will ensure that all batteries will converge to the same state of charge.

If needed, several balancers can be paralleled. A 48V battery bank can be balanced with three Battery Balancers.

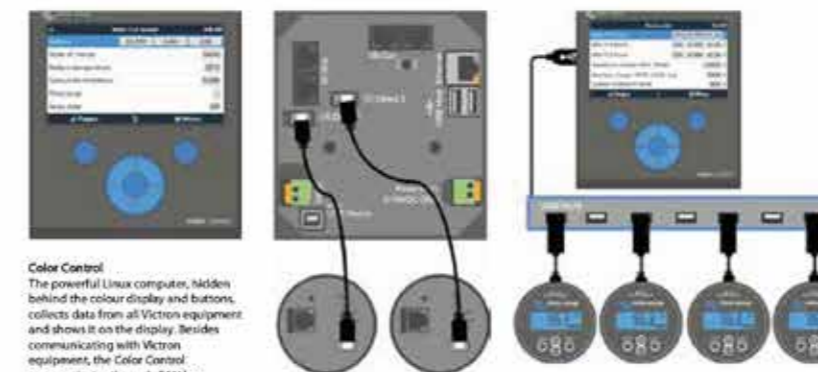

Color Control
The powerful Linux computer, hidden behind the colour display and buttons, collects data from all Victron equipment and shows it on the display. Besides communicating with Victron equipment, the Color Control communicates through CAN bus (J1939), Ethernet and USB. Data can be stored and analysed on the VIM Portal.

A maximum of four BMVs can be connected directly to a Color Control GX. Even more BMVs can be connected to a USB Hub for central monitoring.



Venus GX
The Venus GX provides intuitive control and monitoring. It has the same functionality as the Color Control GX, with a few extras:
- Lower cost, mainly because it has no display or buttons
- 3 tank sender inputs
- 2 temperature inputs

BMV-700 series: precision battery monitoring

- [Application Examples](#)
- [Motorhomes](#)
- [Ambulances](#)
- [Coffee cart Espresso Systems](#)
- [Accessories](#)
- [Tools](#)
- [Technical information](#)



BMV-700



BMV bezel square



BMV shunt 500A/50mV
With quick connect pcb



BMV-702 Black



BMV-700H

Battery 'fuel gauge', time-to-go indicator, and much more

The remaining battery capacity depends on the ampere-hours consumed, discharge current, temperature and the age of the battery. Complex software algorithms are needed to take all these variables into account.

Next to the basic display options, such as voltage, current and ampere-hours consumed, the BMV-700 series also displays state of charge, time to go, and power consumption in Watts.

The BMV-702 features an additional input which can be programmed to measure the voltage (of a second battery), battery temperature or midpoint voltage (see below).

Bluetooth Smart

Use the Bluetooth Smart dongle to monitor your batteries on Apple or Android smartphones, tablets, macbooks and other devices.

Easy to install

All electrical connections are to the quick connect PCB on the current shunt. The shunt connects to the monitor with a standard RJ12 telephone cable. Included: RJ12 cable (10m) and battery cable with fuse (2m); no other components needed.

Also included are a separate front bezel for a square or round display appearance, a securing ring for the rear mounting and screws for the front mounting.

Easy to program (with your smartphone)

A quick install menu and a detailed setup menu with scrolling texts assist the user when going through the various settings.

Alternatively, choose the fast and easy solution: download the smartphone app (Bluetooth Smart dongle needed)

Midpoint voltage monitoring (BMV-702 only)

This feature, which is often used in industry to monitor large and expensive battery banks, is now for the first time made available at a low cost, to monitor any battery bank.

A battery bank consists of a string of series connected cells. The midpoint voltage is the voltage halfway along the string. Ideally, the midpoint voltage would be exactly half of the total voltage. In practice, however, deviations will be seen, that depend on many factors such as a different state of charge for new batteries or cells, different temperatures, internal leakage currents, capacities and much more.

Large or increasing deviation of the midpoint voltage, points to improper battery care or a failed battery or cell. Corrective action following a midpoint voltage alarm can prevent severe damage to an expensive battery. Please consult the BMV manual for more information.

Standard features

- Battery voltage, current, power, ampere-hours consumed and state of charge
- Remaining time at the current rate of discharge
- Programmable visual and audible alarm
- Programmable relay, to turn off non critical loads or to run a generator when needed
- 500 Amp quick connect shunt and connection kit
- Shunt selection capability up to 10,000 Amps
- VE.Direct communication port
- Stores a wide range of historical events, which can be used to evaluate usage patterns and battery health
- Wide input voltage range: 6.5 – 95V
- High current measurement resolution: 10 mA (0.01A)
- Low current consumption: 2.9Ah per month (4mA) @12V and 2.2Ah per month (3mA) @ 24V

BMV-702 additional features

Additional input to measure voltage (of a second battery), temperature or midpoint voltage, and corresponding alarm and relay settings.

BMV-700H: 60 to 385 VDC voltage range

No additional parts needed. Note: suitable for systems with grounded negative only (battery monitor is not isolated from shunt).

Other battery monitoring options

- Lynx Shunt VE.Can

More about midpoint voltage

One bad cell or one bad battery can destroy a large, expensive battery bank. When batteries are connected in series, a timely warning can be generated by measuring the midpoint voltage. Please see the BMV manual, section 5.2, for more information.

We recommend our **Battery Balancer** (BMS012201000) to maximize service life of series-connected batteries.

Battery Monitor	BMV-700	BMV-702 BMV-702 BLACK	BMV-700H
Supply voltage range	6.5 - 95 VDC	6.5 - 95 VDC	60 - 385 VDC
Current draw, back light off	< 4mA	< 4mA	< 4mA
Input voltage range, auxiliary battery	n. a.	6.5 - 95 VDC	n. a.
Battery capacity (Ah)		1 - 9999 Ah	
Operating temperature range		-40 +50°C (-40 - 120°F)	
Measures voltage of second battery, or temperature, or midpoint	No	Yes	No
Temperature measurement range		-20 +50°C	n. a.
VE.Direct communication port	Yes	Yes	Yes
Relay		60V / 1A normally open (function can be inverted)	
RESOLUTION & ACCURACY (with a 500 A shunt)			
Current		± 0.01A	
Voltage		± 0.01V	
Amp hours		± 0.1 Ah	
State of charge (0 - 100%)		± 0.1%	
Time to go		± 1 min	
Temperature (0 - 50°C or 30 - 120°F)	n. a.	± 1°C/°F	n. a.
Accuracy of current measurement		± 0.4%	
Accuracy of voltage measurement		± 0.3%	
INSTALLATION & DIMENSIONS			
Installation		Flush mount	
Front		63mm diameter	
Front bezel		69 x 69 mm (2.7 x 2.7 inch)	
Body diameter and depth		52 mm (2.0 inch) and 31 mm (1.2 inch)	
Protection category		IP55 (not intended for outdoor use)	
STANDARDS			
Safety		EN 60335-1	
Emission / Immunity		EN 55014-1 / EN 55014-2	
Automotive		ECE R10-4 / EN 50498	
ACCESSORIES			
Shunt (included)		500A / 50mV	
Cables (included)		10 meter 6 core UTP with RJ12 connectors, and cable with fuse for '-' connection	
Temperature sensor		Optional (ASS000100000)	



1000A/50mV, 2000A/50mV and 6000A/50mV shunt
The quick connect PCB on the standard 500A/50mV shunt can also be mounted on these shunts.



Interface cables
- VE.Direct cables to connect a BMV 70x to the Color Control (ASS03030xxx)
- VE.Direct to USB interface (ASS030530000) to connect several BMV 70x to a Color Control GX or to a computer.



With the VE.Direct to Bluetooth Smart dongle real time data and alarms can be displayed on Apple and Android smartphones, tablets, macbooks and other devices.



See the VictronConnect BMV app Discovery Sheet for more screenshots

Also use your smartphone to adjust settings!
(the VE.Direct to Bluetooth Smart dongle must be ordered separately)



Color Control
The powerful Linux computer, hidden behind the colour display and buttons, collects data from all Victron equipment and shows it on the display. Besides communicating with Victron equipment, the Color Control communicates through CAN bus (NMEA2000), Ethernet and USB. Data can be stored and analysed on the VRM Portal.

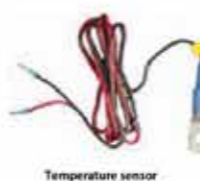
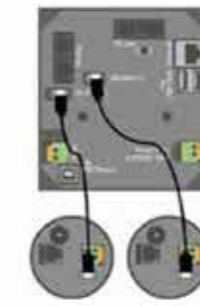

Temperature sensor



A maximum of four BMVs can be connected directly to a Color Control GX. Even more BMVs can be connected to a USB Hub for central monitoring.



Battery Balancer (BMS012201000)
The Battery Balancer equalises the state of charge of two series connected 12V batteries, or of several parallel strings of series connected batteries. When the charge voltage of a 24V battery system increases to more than 27V, the Battery Balancer will turn on and compare the voltage over the two series connected batteries. The Battery Balancer will draw a current of up to 1A from the battery (or parallel connected batteries) with the highest voltage. The resulting charge current differential will ensure that all batteries will converge to the same state of charge.

If needed, several balancers can be paralleled.
A 48V battery bank can be balanced with three Battery Balancers.

Argo diode battery isolators



Argo Diode Isolator
120-2AC



Argo Diode Isolator
140-3AC

Diode battery isolators allow simultaneous charging of two or more batteries from one alternator, without connecting the batteries together. Discharging the accessory battery for example will not result in also discharging the starter battery.

The Argo Battery Isolators feature a low voltage drop thanks to the use of Schottky diodes: at low current the voltage drop is approximately 0,3 V and at the rated output approximately 0,45 V. All models are fitted with a compensation diode that can be used to slightly increase the output voltage of the alternator. This compensates for the voltage drop over the diodes in the isolator.

Please see our book 'Energy Unlimited' or ask for specialist advice when installing a diode isolator. Simply inserting the isolator in the cabling between the alternator and the batteries will slightly reduce charge voltage. The result can be that batteries are not charged to the full 100% and age prematurely.

Alternator energize input

Some alternators need DC voltage on the B+ output to start charging. Obviously, DC will be present when the alternator is directly connected to a battery. Inserting a Diode or FET splitter will however prevent any return voltage/current from the batteries to the B+, and the alternator will not start.

The new 'AC' diode isolators feature a special current limited energize input that will power the B+ when the engine run/stop switch is closed.

Argo Diode Battery Isolator	80-2SC	80-2AC	100-3AC	120-2AC	140-3AC	160-2AC	180-3AC
Maximum charge current (A)	80	80	100	120	140	160	180
Maximum alternator current (A)	80	80	100	120	140	160	180
Number of batteries	2	2	3	2	3	2	3
Alternator Energize Input	no	yes	yes	yes	yes	yes	yes
Connection	M6 Studs	M6 Studs	M6 Studs	M8 Studs	M8 Studs	M8 Studs	M8 Studs
Compensation diode and Energize connection	6,3 mm Faston	6,3 mm Faston	6,3 mm Faston	6,3 mm Faston	6,3 mm Faston	6,3 mm Faston	6,3 mm Faston
Weight kg (lbs)	0,5 (1.3)	0,6 (1.3)	0,8 (1.8)	0,8 (1.8)	1,1 (2.5)	1,1 (2.5)	1,5 (3.3)
Dimensions h x w x d in mm (h x w x d in inches)	60 x 120 x 75 (2.4 x 4.7 x 3.0)	60 x 120 x 90 (2.4 x 4.7 x 3.9)	60 x 120 x 115 (2.4 x 4.7 x 4.5)	60 x 120 x 115 (2.4 x 4.7 x 4.5)	60 x 120 x 150 (2.4 x 4.7 x 5.9)	60 x 120 x 150 (2.4 x 4.7 x 5.9)	60 x 120 x 200 (2.4 x 4.7 x 7.9)

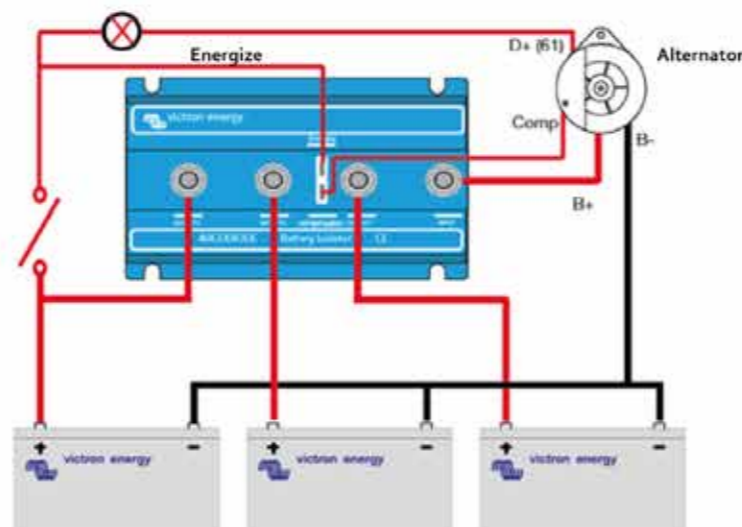

Argo FET battery isolators



Argo FET 100-3
3bat 100A



Argo FET 100-3
3bat 100A

Similarly to Diode Battery Isolators, FET Isolators allow simultaneous charging of two or more batteries from one alternator (or a single output battery charger), without connecting the batteries together. Discharging the accessory battery for example will not result in also discharging the starter battery.

In contrast with Diode Battery Isolators, FET Isolators have virtually no voltage loss. Voltage drop is less than 0,02 Volt at low current and averages 0,1 Volt at higher currents.

When using Argo FET Battery Isolators, there is no need to also increase the output voltage of the alternator. However, care should be taken to keep cable lengths short and of sufficient cross section.

Example:

When a current of 100 A flows through a cable of 50 mm² cross section (AWG 0) and 10 m length (30 ft), the voltage drop over the cable will be 0,26 Volt. Similarly a current of 50 A through a cable of 10 mm² cross section (AWG 7) and 5 m length (15 ft) will result in a voltage drop of 0,35 Volt!

Alternator energize input

Some alternators need DC voltage on the B+ output to start charging. Obviously, DC will be present when the alternator is directly connected to a battery. Inserting a Diode or FET splitter will however prevent any return voltage/current from the batteries to the B+, and the alternator will not start.

The new Argo FET Isolators have a special current limited energize input that will power the B+ when the engine run/stop switch is closed.

Argo FET Battery Isolator	Argo FET 100-2	Argo FET 100-3	Argo FET 200-2	Argo FET 200-3
Maximum charge current (A)	100	100	200	200
Maximum alternator current (A)	100	100	200	200
Number of batteries	2	3	2	3
Connection	M8 bolts	M8 bolts	M8 bolts	M8 bolts
Weight kg (lbs)	1,4 (3.1)	1,4 (3.1)	1,4 (3.1)	1,4 (3.1)
Dimensions: h x w x d in mm (h x w x d in inches)	65 x 120 x 200 (2.6 x 4.7 x 7.9)	65 x 120 x 200 (2.6 x 4.7 x 7.9)	65 x 120 x 200 (2.6 x 4.7 x 7.9)	65 x 120 x 200 (2.6 x 4.7 x 7.9)

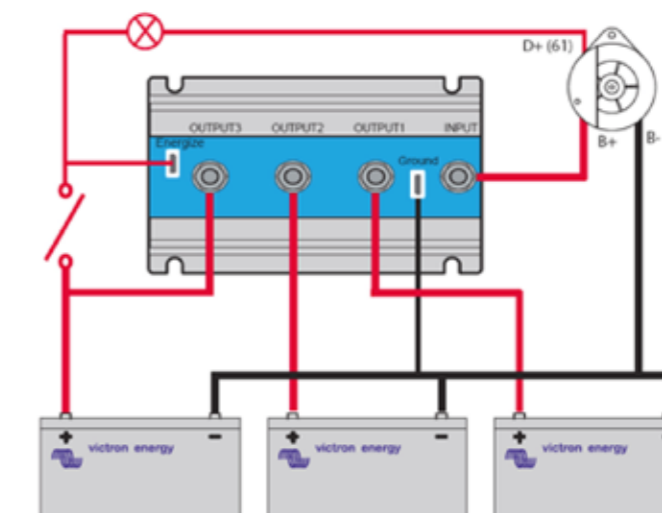

Battery Balancer

The problem: the service life of an expensive battery bank can be substantially shortened due to state of charge unbalance
 One battery with a slightly higher internal leakage current in a 24V or 48V bank of several series/parallel connected batteries will cause undercharge of that battery and parallel connected batteries, and overcharge of the series connected batteries. Moreover, when new cells or batteries are connected in series, they should all have the same initial state of charge. Small differences will be ironed out during absorption or equalize charging, but large differences will result in damage due to excessive gassing (caused by overcharging) of the batteries with the higher initial state of charge and sulphation (caused by undercharging) of the batteries with the lower initial state of charge.

The Solution: battery balancing

The Battery Balancer equalizes the state of charge of two series connected 12V batteries, or of several parallel strings of series connected batteries.
 When the charge voltage of a 24V battery system increases to more than 27,3V, the Battery Balancer will turn on and compare the voltage over the two series connected batteries. The Battery Balancer will draw a current of up to 0,7A from the battery (or parallel connected batteries) with the highest voltage. The resulting charge current differential will ensure that all batteries will converge to the same state of charge.

If needed, several balancers can be paralleled.
 A 48V battery bank can be balanced with three Battery Balancers.

LED indicators

- Green:** on (battery voltage > 27,3V)
- Orange:** lower battery leg active (deviation > 0,1V)
- Orange:** upper battery leg active (deviation > 0,1V)
- Red:** alarm (deviation > 0,2V). Remains on until the deviation has reduced to less than 0,14V, or until system voltage drops to less than 26,6V.

Alarm relay

Normally open. The alarm relay closes when the red LED switches on and opens when the red LED switches off.

Alarm reset

Two terminals are available to connect a push button. Interconnecting the two terminals resets the relay.
 The reset condition will remain active until the alarm is over. Thereafter the relay will close again when a new alarm occurs.

Even more insight and control with the midpoint monitoring function of the BMV-702 Battery Monitor

The BMV-702 measures the midpoint of a string of cells or batteries. It displays the deviation from the ideal midpoint in volts or percent. Separate deviation percentages can be set to trigger a visual/audible alarm and to close a potential free relay contact for remote alarm purposes.
 Please see the manual of the BMV-702 for more information about battery balancing.

Learn more about batteries and battery charging

To learn more about batteries and charging batteries, please refer to our book 'Energy Unlimited' (available free of charge from Victron Energy and downloadable from www.victronenergy.com).

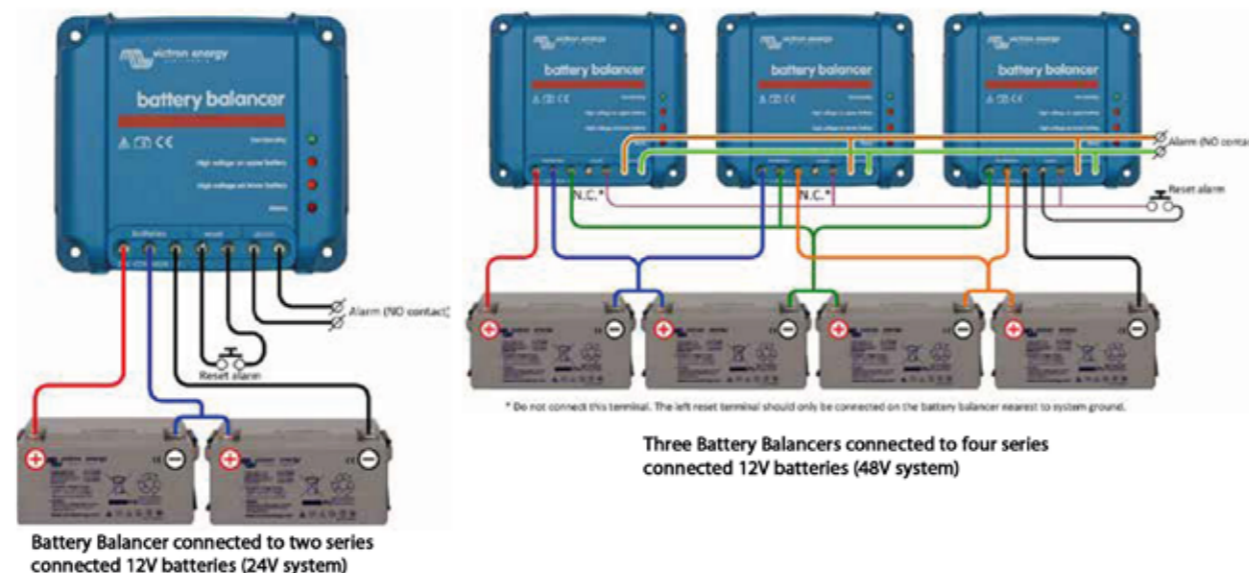

Victron Battery Balancer	
Input voltage range	Up to 18V per battery, 36V total
Turn on level	27,3V +/- 1%
Turn off level	26,6V +/- 1%
Current draw when off	0,7 mA
Midpoint deviation to start balancing	50 mV
Maximum balancing current	0,7A (when deviation > 100 mV)
Alarm trigger level	200 mV
Alarm reset level	140 mV
Alarm relay	60V / 1A normally open
Alarm relay reset	Two terminals to connect a push button
Over temperature protection	yes
Operating temperature	-30 to +50°C
Humidity (non-condensing)	95%
ENCLOSURE	
Colour	Blue (RAL 5012)
Connection terminals	Screw terminals 6 mm ² / AWG10
Protection category	IP22
Weight	0,4 kg
Dimensions (h x w x d)	100 x 113 x 47 mm
STANDARDS	
Safety	EN 60950, CSA/UL 62368-1
Emission	EN 61000-6-3, EN 55014-1
Immunity	EN 61000-6-2, EN 61000-6-1, EN 55014-2
Automotive Directive	EN 50498

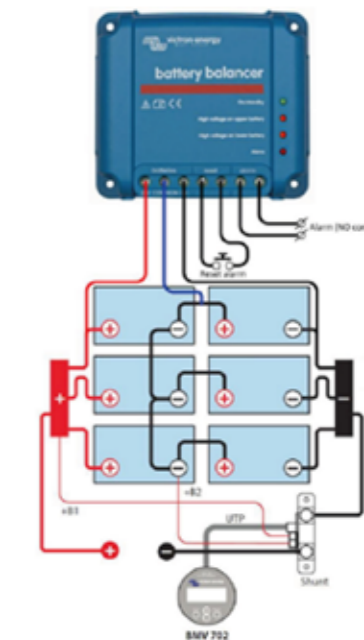

- ### Installation
- The Battery Balancer(s) must be installed on a well-ventilated vertical surface close to the batteries (but, due to possible corrosive gasses, not above the batteries!)
 - In case of series-parallel connection, the midpoint interconnecting cables must be sized to at least carry the current that arises when one battery becomes open-circuited.
 - In case of 2 parallel strings: cross section 50% of the series interconnecting cables.
 - In case of 3 parallel strings: cross section 33% of the series interconnecting cables, etc.
 - If required: first wire the alarm contact and the alarm reset.
 - Use at least 0,75 mm² to wire the negative, positive and midpoint connections (in this order). Additionally, if in your application it is needed to comply with UL, also fuse these wires near the batteries with a 10A fuse suitable for DC current (e.g. Littelfuse ATOF series automotive blade fuse in combination with an inline fuse holder).
 - The balancer is operational.
 - When the voltage over a string of two batteries is less than 26,6V the balancer switches to standby and all LEDs will be off.
 - When the voltage over a string of two batteries increases to more than 27,3V (during charging) the green LED will turn on, indicating that the balancer is on.
 - When on, a voltage deviation of more than 50 mV will start the balancing process and at 100 mV one of the two orange LEDs will turn on. A deviation of more than 200 mV will trigger the alarm relay.

- ### What to do in case of an alarm during charging
- In case of a new battery bank the alarm is probably due to differences in initial state-of-charge. If the difference between the lowest and highest battery voltage reading is more than 0,9V: stop charging and charge the individual batteries or cells separately first, or reduce charge current substantially and allow the batteries to equalize over time.
- If the problem persists after several charge-discharge cycles:
- In case of series-parallel connection disconnect the midpoint parallel connection wiring and measure the individual midpoint voltages during absorption charge to isolate batteries or cells which need additional charging, or:
 - Charge and then test all batteries or cells individually or:
 - Connect two or more battery balancers in parallel (on average one balancer will take care of up to three parallel 200 Ah strings).

- In case of an older battery bank which has performed well in the past, the problem may be due to:
- Systematic undercharge: more frequent charging needed (VRLA batteries), or equalization charge needed (flooded deep cycle flat plate or OPzS batteries). Better and regular charging will solve the problem.
 - One or more faulty cells: replace all batteries.

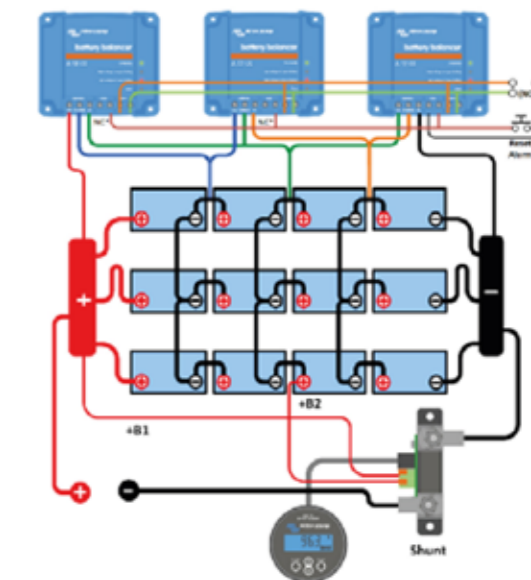

GEL and AGM batteries

[Application Examples](#)

[Motorhomes](#)

[Ambulances](#)

[Coffee cart Espresso](#)

[Systems](#)

[Accessories](#)

[Tools](#)

[Technical information](#)



AGM Battery
12V 90Ah



GEL OPzV 2V cell

1. VRLA technology

VRLA stands for Valve Regulated Lead Acid, which means that the batteries are sealed. Gas will escape through the safety valves only in case of overcharging or cell failure. VRLA batteries are maintenance free for life.

2. Sealed (VRLA) AGM Batteries

AGM stands for Absorbent Glass Mat. In these batteries the electrolyte is absorbed into a glass-fibre mat between the plates by capillary action. As explained in our book 'Energy Unlimited', AGM batteries are more suitable for short-time delivery of high currents than gel batteries.

3. Sealed (VRLA) Gel Batteries

Here the electrolyte is immobilized as gel. Gel batteries in general have a longer service life and better cycle capacity than AGM batteries.

4. Low Self-Discharge

Because of the use of lead calcium grids and high purity materials, Victron VRLA batteries can be stored during long periods of time without recharge. The rate of self-discharge is less than 2% per month at 20°C. The self-discharge doubles for every increase in temperature by 10°C.

Victron VRLA batteries can therefore be stored for up to a year without recharging, if kept under cool conditions.

5. Exceptional Deep Discharge Recovery

Victron VRLA batteries have exceptional discharge recovery, even after deep or prolonged discharge.

Nevertheless repeatedly deep and prolonged discharge has a very negative effect on the service life of all lead acid batteries. Victron batteries are no exception.

6. Battery Discharging Characteristics

The rated capacity of Victron AGM and Gel Deep Cycle batteries refers to 20 hour discharge, in other words: a discharge current of 0,05 C.

The rated capacity of Victron Tubular Plate Long Life batteries refers to 10 hours discharge.

The effective capacity decreases with increasing discharge current (see table 1). Please note that the capacity reduction will be even faster in case of a constant power load, such as an inverter.

Discharge time (constant current)	End Voltage V	AGM 'Deep Cycle' %	Gel 'Deep Cycle' %	Gel 'Long Life' %
20 hours	10,8	100	100	112
10 hours	10,8	92	87	100
5 hours	10,8	85	80	94
3 hours	10,8	78	73	79
1 hour	9,6	65	61	63
30 min.	9,6	55	51	45
15 min.	9,6	42	38	29
10 min.	9,6	38	34	21
5 min.	9,6	27	24	
5 seconds		8 C	7 C	

Table 1: Effective capacity as a function of discharge time (the lowest row gives the maximum allowable 5 seconds discharge current)

Our AGM deep cycle batteries have excellent high current performance and are therefore recommended for high current applications such as engine starting. Due to their construction, Gel batteries have a lower effective capacity at high discharge currents. On the other hand, Gel batteries have a longer service life, both under float and cycling conditions.

7. Effect of temperature on service life

High temperature has a very negative effect on service life. The service life of Victron batteries as a function of temperature is shown in table 2.

Average Temperature	AGM 'Deep Cycle' years	Gel 'Deep Cycle' years	Gel 'Long Life' years
20°C / 68°F	7 - 10	12	20
30°C / 86°F	4	6	10
40°C / 104°F	2	3	5

Table 2: Design service life of Victron batteries under float service

8. Effect of temperature on capacity

As is shown by the graph below, capacity reduces sharply at low temperatures.

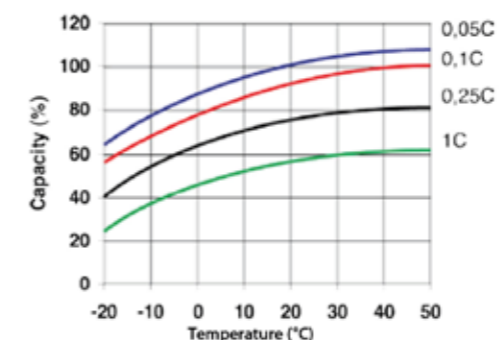

Fig. 1: Effect of temperature on capacity

9. Cycle life of Victron batteries

Batteries age due to discharging and recharging. The number of cycles depends on the depth of discharge, as is shown in figure 2.

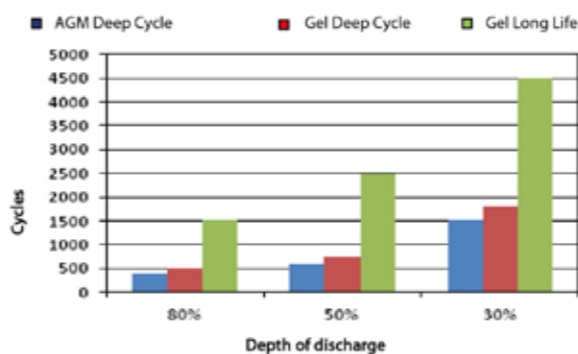

Fig. 2: Cycle life

10. Battery charging in case of cycle use: the 3-step charge curve

The most common charge curve used to charge VRLA batteries in case of cyclic use is the 3-step charge curve, whereby a constant current phase (the bulk phase) is followed by two constant voltage phases (absorption and float), see fig. 3.

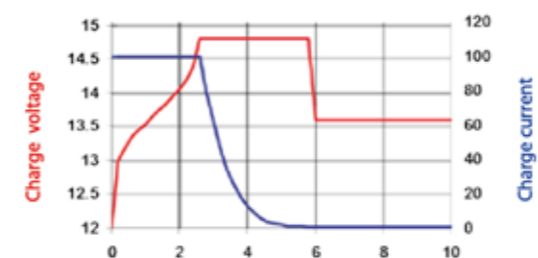

Fig. 3: Three step charge curve

During the absorption phase the charge voltage is kept at a relatively high level in order to fully recharge the battery within reasonable time. The third and last phase is the float phase: the voltage is lowered to standby level, sufficient to compensate for self-discharge.

Gel and AGM batteries

Disadvantages of the traditional 3-step charge curve:

- During the bulk phase the current is kept at a constant and often high level, even after the gassing voltage (14,34V for a 12V battery) has been exceeded. This can lead to excessive gas pressure in the battery. Some gas will escape through the safety valves, reducing service life.
- Thereafter the absorption voltage is applied during a fixed period of time, irrespective of how deep the battery has been discharged previously. A full absorption period after a shallow discharge will overcharge the battery, again reducing service life (a.o. due to accelerated corrosion of the positive plates).
- Research has shown that battery life can be increased by decreasing float voltage to an even lower level when the battery is not in use.

11. Battery charging: longer battery life with Victron 4-step adaptive charging

Victron developed the adaptive charge curve. The 4-step adaptive charge curve is the result of years of research and testing.

The Victron four-step adaptive charge curve solves the 3 main problems of the 3-step curve:

- **Battery Safe Mode**
In order to prevent excessive gassing, Victron has invented the 'Battery Safe Mode'. The Battery Safe Mode will limit the rate of voltage increase once the gassing voltage has been reached. Research has shown that this will reduce internal gassing to a safe level.
- **Variable absorption time**
Based on the duration of the bulk stage, the charger calculates how long the absorption time should be in order to fully charge the battery. If the bulk time is short, this means the battery was already charged and the resulting absorption time will also be short, whereas a longer bulk time will also result in a longer absorption time.
- **Storage mode**
After completion of the absorption period the battery should be fully charged, and the voltage is lowered to the float or standby level. If no discharge occurs during the next 24 hours, the voltage is reduced even further and the battery goes into storage mode. The lower storage voltage reduces corrosion of the positive plates. Once every week the charge voltage is increased to the absorption level for a short period to compensate for self-discharge (Battery Refresh mode).

12. Battery charging in case of standby use: constant voltage float charging

When a battery is not frequently deeply discharged, a 2-step charge curve can be used. During the first phase the battery is charged with a limited current (the bulk phase). Once a pre-set voltage has been reached the battery is kept at that voltage (the float phase).

This charge method is used for starter batteries in vehicles and in uninterruptible power supplies (UPS).

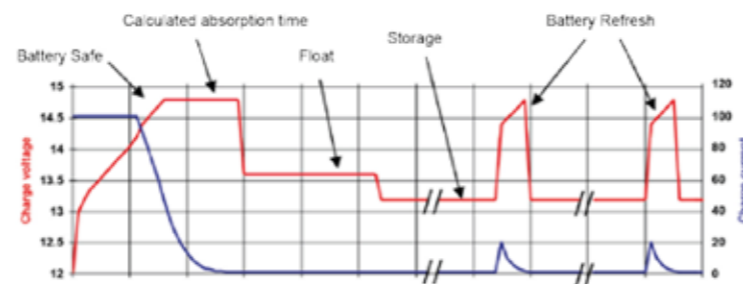

Fig. 4: Four-step adaptive charge curve

13. Optimum charge voltage of Victron VRLA batteries

The recommended charge voltage settings for a 12V battery are shown in table 3.

14. Effect of temperature on charging voltage

The charge voltage should be reduced with increased temperature. Temperature compensation is required when the temperature of the battery is expected to be less than 10°C / 50°F or more than 30°C / 85°F during long periods of time. The recommended temperature compensation for Victron VRLA batteries is -4 mV / Cell (-24 mV / °C for a 12V battery). The centre point for temperature compensation is 25°C / 70°F.

15. Charge current

The charge current should preferably not exceed 0,2C (20A for a 100Ah battery). The temperature of a battery will increase by more than 10°C if the charge current exceeds 0,2C. Therefore temperature compensation is required if the charge current exceeds 0,2C.

	Float Service (V)	Cycle service Normal (V)	Cycle service Fastest recharge (V)
Victron AGM 'Deep Cycle'			
Absorption		14,2 - 14,6	14,6 - 14,9
Float	13,5 - 13,8	13,5 - 13,8	13,5 - 13,8
Storage	13,2 - 13,5	13,2 - 13,5	13,2 - 13,5
Victron Gel 'Deep Cycle'			
Absorption		14,1 - 14,4	
Float	13,5 - 13,8	13,5 - 13,8	
Storage	13,2 - 13,5	13,2 - 13,5	
Victron Gel 'Long Life'			
Absorption		14,0 - 14,2	
Float	13,5 - 13,8	13,5 - 13,8	
Storage	13,2 - 13,5	13,2 - 13,5	

Table 3: Recommended charge voltage

12 Volt Deep Cycle AGM							General Specification
Article number	Ah	V	l x w x h mm	Weight kg	CCA @0°F	RES CAP @80°F	Technology: flat plate AGM Terminals: copper
BAT406225084	240	6	320 x 176 x 247	31	700	270	Rated capacity: 20 hr. discharge at 25°C Float design life: 7-10 years at 20°C Cycle design life: 400 cycles at 80% discharge 600 cycles at 50% discharge 1500 cycles at 30% discharge
BAT212070084	8	12	151 x 65 x 101	2,5			
BAT212120086	14	12	151 x 98 x 101	4,4			
BAT212200084	22	12	181 x 77 x 167	5,8			
BAT412350084	38	12	197 x 165 x 170	12,5			
BAT412550084	60	12	229 x 138 x 227	20	280	80	
BAT412600084	66	12	258 x 166 x 235	24	300	90	
BAT412800084	90	12	350 x 167 x 183	27	400	130	
BAT412101084	110	12	330 x 171 x 220	32	500	170	
BAT412121084	130	12	410 x 176 x 227	38	550	200	
BAT412151084	165	12	485 x 172 x 240	47	600	220	
BAT412201084	220	12	522 x 238 x 240	65	650	250	
BAT412124081	240	12	522 x 240 x 224	67	650	250	

12 Volt Deep Cycle GEL							General Specification
Article number	Ah	V	l x w x h mm	Weight kg	CCA @0°F	RES CAP @80°F	Technology: flat plate GEL Terminals: copper
BAT412550104	60	12	229 x 138 x 227	20	250	70	Rated capacity: 20 hr. discharge at 25°C Float design life: 12 years at 20°C Cycle design life: 500 cycles at 80% discharge 750 cycles at 50% discharge 1800 cycles at 30% discharge
BAT412600100	66	12	258 x 166 x 235	24	270	80	
BAT412800104	90	12	350 x 167 x 183	26	360	120	
BAT412101104	110	12	330 x 171 x 220	33	450	150	
BAT412121104	130	12	410 x 176 x 227	38	500	180	
BAT412151104	165	12	485 x 172 x 240	48	550	200	
BAT412201104	220	12	522 x 238 x 240	66	600	220	
BAT412126101	265	12	520 x 268 x 223	75	650	250	

2 Volt Long Life GEL					General Specification
Article number	Ah	V	l x b x h mm	Weight kg	Technology: tubular plate GEL Terminals: copper
BAT702601260	600	2	145 x 206 x 688	49	Rated capacity: 10 hr. discharge at 25°C Float design life: 20 years at 20°C Cycle design life: 1500 cycles at 80% discharge 2500 cycles at 50% discharge 4500 cycles at 30% discharge
BAT702801260	800	2	210 x 191 x 688	65	
BAT702102260	1000	2	210 x 233 x 690	80	
BAT702122260	1200	2	210 x 275 x 690	93	
BAT702152260	1500	2	210 x 275 x 840	115	
BAT702202260	2000	2	215 x 400 x 815	155	
BAT702252260	2500	2	215 x 490 x 815	200	
BAT702302260	3000	2	215 x 580 x 815	235	

Other capacities and terminal types: at request

[Application Examples](#)

[Motorhomes](#)

[Ambulances](#)

[Coffee cart Espresso](#)

[Systems](#)

[Accessories](#)

[Tools](#)

[Technical information](#)

12,8 Volt Lithium Iron Phosphate Batteries Smart

With Bluetooth

[Application Examples](#)

[Motorhomes](#)

[Ambulances](#)

[Coffee cart Espresso](#)

[Systems](#)

[Accessories](#)

[Tools](#)

[Technical information](#)



12,8V 300Ah LiFePO4 Battery



LI-Ion app

Why lithium-iron-phosphate?

Lithium-iron-phosphate (LiFePO₄ or LFP) is the safest of the mainstream li-ion battery types. The nominal voltage of a LFP cell is 3,2V (lead-acid: 2V/cell). A 12,8V LFP battery therefore consists of 4 cells connected in series; and a 25,6V battery consists of 8 cells connected in series.

Rugged

A lead-acid battery will fail prematurely due to sulfation:

- If it operates in deficit mode during long periods of time (i.e. if the battery is rarely, or never at all, fully charged).
- If it is left partially charged or worse, fully discharged (yacht or mobile home during wintertime).

A LFP battery does not need to be fully charged. Service life even slightly improves in case of partial charge instead of a full charge. This is a major advantage of LFP compared to lead-acid.

Other advantages are the wide operating temperature range, excellent cycling performance, low internal resistance and high efficiency (see below).

LFP is therefore the chemistry of choice for demanding applications.

Efficient

In several applications (especially off-grid solar and/or wind), energy efficiency can be of crucial importance. The round-trip energy efficiency (discharge from 100% to 0% and back to 100% charged) of the average lead-acid battery is 80%.

The round-trip energy efficiency of a LFP battery is 92%.

The charge process of lead-acid batteries becomes particularly inefficient when the 80% state of charge has been reached, resulting in efficiencies of 50% or even less in solar systems where several days of reserve energy is required (battery operating in 70% to 100% charged state).

In contrast, a LFP battery will still achieve 90% efficiency under shallow discharge conditions.

Size and weight

Saves up to 70% in space

Saves up to 70% in weight

Expensive?

LFP batteries are expensive when compared to lead-acid. But in demanding applications, the high initial cost will be more than compensated by longer service life, superior reliability and excellent efficiency.

Bluetooth

With Bluetooth cell voltages, temperature and alarm status can be monitored.

Very useful to localize a (potential) problem, such as cell imbalance.

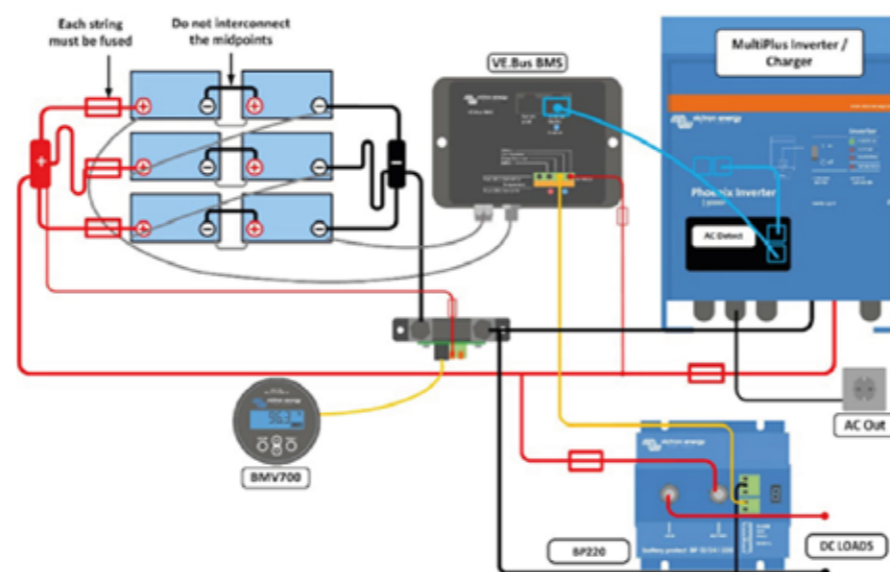

Our LFP batteries have integrated cell balancing and cell monitoring. Up to 5 batteries can be paralleled and up to four 12V batteries or two 24V batteries can be series connected, so that a 48V battery bank of up to 1500Ah can be assembled. The cell balancing/monitoring cables can be daisy-chained and must be connected to a Battery Management System (BMS).

Battery Management System (BMS)

The BMS will:

1. Generate a pre-alarm whenever the voltage of a battery cell decreases to less than 3,1V (adjustable 2,85-3,15V).
2. Disconnect or shut down the load whenever the voltage of a battery cell decreases to less than 2,8V (adjustable 2,6V-2,8V).
3. Stop the charging process whenever the voltage of a battery cell increases to more than 4,2V.
4. Shut down the system whenever the temperature of a cell exceeds 50°C.

See the BMS datasheets for more features

Battery specification

VOLTAGE AND CAPACITY	LFP-Smart 12,8/50	LFP-Smart 12,8/60	LFP-Smart 12,8/100	LFP-Smart 12,8/160	LFP-Smart 12,8/200	LFP-Smart 12,8/300	LFP-Smart 25,6/200
Nominal voltage	12,8V	12,8V	12,8V	12,8V	12,8V	12,8V	25,6V
Nominal capacity @ 25°C*	50Ah	60Ah	100Ah	160Ah	200Ah	300Ah	200Ah
Nominal capacity @ 0°C*	40Ah	48Ah	80Ah	130Ah	160Ah	240Ah	160Ah
Nominal capacity @ -20°C*	25Ah	30Ah	50Ah	80Ah	100Ah	150Ah	100Ah
Nominal energy @ 25°C*	640Wh	768Wh	1280Wh	2048Wh	2560Wh	3840Wh	5120Wh
*Discharge current ≤1C							
CYCLE LIFE (capacity ≥ 80% of nominal)							
80% DoD	2500 cycles						
70% DoD	3000 cycles						
50% DoD	5000 cycles						
DISCHARGE							
Maximum continuous discharge current	100A	120A	200A	320A	400A	600A	400A
Recommended continuous discharge current	≤50A	≤60A	≤100A	≤160A	≤200A	≤300A	≤200A
End of discharge voltage	11,2V	11,2V	11,2V	11,2V	11,2V	11,2V	22,4V
OPERATING CONDITIONS							
Operating temperature	Discharge: -20°C to +50°C Charge: +5°C to +50°C						
Storage temperature	-45°C to +70°C						
Humidity (non-condensing)	Max. 95%						
Protection class	IP 22						
CHARGE							
Charge voltage	Between 14V/28V and 14,4V/28,8V (14,2V/28,4V recommended)						
Float voltage	13,5V/27V						
Maximum charge current	100A	120A	200A	320A	400A	600A	400A
Recommended charge current	≤30A	≤30A	≤50A	≤80A	≤100A	≤150A	≤100A
OTHER							
Max storage time @ 25°C*	1 year						
BMS connection	Male + female cable with M8 circular connector, length 50cm						
Power connection (threaded inserts)	M8	M8	M8	M8	M8	M10	M8
Dimensions (l x w x d) mm	199 x 188 x 147	239 x 286 x 132	197 x 321 x 152	237 x 321 x 152	237 x 321 x 152	347 x 425 x 274	317 x 631 x 208
Weight	7kg	12kg	15kg	20kg	22kg	51kg	56kg
*When fully charged.							

12,8V & 25,6 Lithium SuperPack batteries

Integrated BMS and safety switch

The SuperPack batteries are extremely easy to install, needing no additional components. The internal switch will disconnect the battery in case of over discharge, over charge, low or high temperature.

Abuse proof

A lead-acid battery will fail prematurely due to sulfation:

- If it operates in deficit mode during long periods of time (i.e. if the battery is rarely, or never at all, fully charged).
- If it is left partially charged or worse, fully discharged.

A Lithium-ion battery does not need to be fully charged. Service life even slightly improves in case of partial charge instead of a full charge. This is a major advantage of Li-ion compared to lead-acid.

The SuperPack batteries will cut-off the charge or discharge current when the maximum ratings are exceeded.

Efficient

In several applications (especially off-grid solar), energy efficiency can be of crucial importance.

The round-trip energy efficiency (discharge from 100% to 0% and back to 100% charged) of the average lead-acid battery is 80%.

The round-trip energy efficiency of a Li-ion battery is 92%.

The charge process of lead-acid batteries becomes particularly inefficient when the 80% state of charge has been reached, resulting in efficiencies of 50% or even less in solar systems where several days of reserve energy are required (battery operating in 70% to 100% charged state).

In contrast, a Li-ion battery will still achieve 90% efficiency even under shallow discharge conditions.

Can be connected in parallel

The batteries can be connected in parallel. Series connection is not allowed. Use in upright position only.



Lithium SuperPack	12,8/20	12,8/60	12,8/100	12,8/100 High current	12,8/200	25,6/50
Chemistry	LiFePO4					
Nominal voltage	12,8 V					25,6 V
Nominal capacity @ 25 °C	20 Ah	60 Ah	100 Ah	200 Ah	50 Ah	
Nominal capacity @ 0 °C	16 Ah	48 Ah	80 Ah	160 Ah	40 Ah	
Nominal energy @ 25 °C	256 Wh	768 Wh	1280 Wh	2560 Wh	1280 Wh	
Cycle life @ 80 % DoD and 25 °C	2500 cycles					
CHARGE and DISCHARGE						
Max. cont. discharge current ⁽¹⁾	30 A	30 A	50 A	100 A	70 A	50 A
Peak discharge current (10 sec)	80 A	80 A	100 A	150 A	100 A	100 A
End of discharge voltage	10 V				20 V	
Charge voltage, absorption ⁽²⁾	14,2 V – 14,4 V				28,4 V – 28,8 V	
Charge voltage, float	13,5 V				27 V	
Max. cont. charge current	15 A	30 A	50 A	100 A	70 A	50 A
OPERATING CONDITIONS						
Parallel configuration	Yes, unlimited					
Series configuration	No					
Operating temperature	Discharge: -20 °C to +50 °C Charge: +0 °C to +45 °C ⁽³⁾					
Storage temperature	-40 °C to +65 °C					
Max. storage time when fully charged	1 year ≤ 25 °C		3 months ≤ 40 °C			
Humidity (non-condensing)	Max. 95 %					
Protection class	IP 43					
OTHER						
Power connection (threaded inserts)	M5	M6	M8	M8	M8	
Dimensions (h x w x d) mm	167 x 181 x 77	213 x 229 x 138	220 x 330 x 172	208 x 520 x 269	220 x 330 x 172	
Weight	3,5 kg	9,5 kg	14 kg	21 kg	14 kg	
<p>1. The battery may disconnect when a load with a high input capacitance is connected, such as an inverter. The battery will however retry and connect after approximately 10 seconds.</p> <p>2. The absorption period should preferably not exceed 4 hrs. A longer absorption period may slightly reduce service life.</p> <p>3. Serial number HQ2040 and newer: charge is automatically blocked when the cell temperature decreases below 0±3 °C. It will accept charging again when increased above 3±3 °C. Discharge is automatically blocked when cell temperature decreases below -20±3 °C. This protection resets when temperature above -15±3 °C.</p>						



Telecom batteries



Telecom Battery
Battery AGM 12V 200Ah

Designed for telecom applications; excellent 'floor space savers' for marine and vehicle applications. The deep cycle AGM telecom series has been designed for use in telecom systems. With front access terminals and small footprint, the batteries are ideal for racked systems. Similarly, these batteries can help solve limited floor space and access problems on board boats and vehicles.

AGM technology

AGM stands for Absorbent Glass Mat. In these batteries the electrolyte is absorbed into a glass-fibre mat between the plates by capillary action.

Low self-discharge

Because of the use of lead calcium grids and high purity materials, Victron VRLA batteries can be stored during long periods of time without recharge. The rate of self-discharge is less than 2% per month at 20°C. The self-discharge doubles for every increase in temperature by 10°C.

Low internal resistance

Accepts very high charge and discharge rates.

High cyclic life capability

More than 500 cycles at 50% depth of discharge.

Learn more about batteries and battery charging

To learn more about batteries and charging batteries, please refer to our book 'Energy Unlimited' (available free of charge from Victron Energy and downloadable from www.victronenergy.com).



Telecom Battery
Battery AGM 12V 200Ah

12V AGM Telecom battery	115Ah	165Ah	200Ah
Capacity 1 / 3 / 5 / 10 / 20 hours (% of nominal)	60 / 75 / 82 / 92 / 100 (@ 70°F/25°C, end of discharge 10,5V)		
Capacity 10 / 20 / 30 / 40 minutes (% of nominal)	33 / 44 / 53 / 57 (@ 70°F/25°C, end of discharge 9,6V)		
Nominal capacity (77°F/25°C, 20,5V)	115Ah	165Ah	200Ah
Cold Cranking Amps @ 0°F/-18°C	1000	1500	1800
DIN cold start current (A) @ 0°F/-18°C	600	900	1000
Short Circuit Current (A)	3500	5000	6000
Reserve Capacity (minutes)	200	320	400
Shelf life @ 70°F/20°C	1 year		
Absorption voltage (V) @ 70°F/20°C	14,4 - 14,7		
Float voltage (V) @ 70°F/20°C	13,6 - 13,8		
Storage voltage (V) @ 70°F/20°C	13,2		
Float design life @ 70°F/20°C	12 years		
Cycle design life @ 80% discharge	500		
Cycle design life @ 50% discharge	750		
Cycle design life @ 30% discharge	1800		
Dimensions (lwxh, mm)	395 x 110 x 293mm	548 x 105 x 316mm	546 x 125 x 323mm
Dimensions (lwxh, inches)	15.37 x 4.33 x 11.53	21.57 x 4.13 x 12.44	21.49 x 4.92 x 12.71
Weight (kg/pounds)	35kg/77lbs	49kg/108lbs	60kg/132lbs

BlueSolar and SmartSolar charge controllers - overview

BlueSolar Charge Controller	Load output	Battery voltage	Optional display	Bluetooth	Com. port	Remote on-off	Programmable relay	Wire Box
75/10	15A	12/24V	MPPT control	Optional dongle	VE.Direct	No	No	S 75-10/15
75/15	15A	12/24V	MPPT control	Optional dongle	VE.Direct	No	No	S 75-10/15
100/15	15A	12/24V	MPPT control	Optional dongle	VE.Direct	No	No	S 100-15
100/20 (up to 48V)	20A/20A/1A	12/24/36/48V	MPPT control	Optional dongle	VE.Direct	No	No	S 100-20
100/30	No	12/24V	MPPT control	Optional dongle	VE.Direct	No	No	M
100/50	No	12/24V	MPPT control	Optional dongle	VE.Direct	No	No	M
150/35	No	12/24/36/48V	MPPT control	Optional dongle	VE.Direct	No	No	M
150/45	No	12/24/36/48V	MPPT control	Optional dongle	VE.Direct	No	No	M
150/45-Tr	No	12/24/36/48V	MPPT control	Optional dongle	VE.Direct	No	No	L
150/45-MC4	No	12/24/36/48V	MPPT control	Optional dongle	VE.Direct	No	No	L
150/60-Tr	No	12/24/36/48V	MPPT control	Optional dongle	VE.Direct	No	No	L
150/60-MC4	No	12/24/36/48V	MPPT control	Optional dongle	VE.Direct	No	No	L
150/70-Tr	No	12/24/36/48V	MPPT control	Optional dongle	VE.Direct	No	No	L
150/70-MC4	No	12/24/36/48V	MPPT control	Optional dongle	VE.Direct	No	No	L
150/100-Tr VE.Can	No	12/24/36/48V	MPPT ctrl & SmartSolar ctrl	Optional dongle	VE.Direct & VE.Can	Yes	Yes	XL
250/70-Tr VE.Can	No	12/24/36/48V	MPPT ctrl & SmartSolar ctrl	Optional dongle	VE.Direct & VE.Can	Yes	Yes	L
250/100-Tr VE.Can	No	12/24/36/48V	MPPT ctrl & SmartSolar ctrl	Optional dongle	VE.Direct & VE.Can	Yes	Yes	XL

SmartSolar Charge Controller	Load output	Battery voltage	Optional display	Bluetooth	Com. port	Remote on-off	Programmable relay	Wire Box
75/10	15A	12/24V	MPPT control	Built-in	VE.Direct	No	No	S 75-10/15
75/15	15A	12/24V	MPPT control	Built-in	VE.Direct	No	No	S 75-10/15
100/15	15A	12/24V	MPPT control	Built-in	VE.Direct	No	No	S 100-15
100/20 (up to 48V)	20A/20A/1A	12/24/36/48V	MPPT control	Built-in	VE.Direct	No	No	S 100-20
100/30	No	12/24V	MPPT control	Built-in	VE.Direct	No	No	M
100/50	No	12/24V	MPPT control	Built-in	VE.Direct	No	No	M
150/35	No	12/24/36/48V	MPPT control	Built-in	VE.Direct	No	No	M
150/45	No	12/24/36/48V	MPPT control	Built-in	VE.Direct	No	No	M
150/45-Tr	No	12/24/36/48V	MPPT ctrl & SmartSolar ctrl	Built-in	VE.Direct	Yes	Yes	L
150/45-MC4	No	12/24/36/48V	MPPT ctrl & SmartSolar ctrl	Built-in	VE.Direct	Yes	Yes	L
150/60-Tr	No	12/24/36/48V	MPPT ctrl & SmartSolar ctrl	Built-in	VE.Direct	Yes	Yes	L
150/60-MC4	No	12/24/36/48V	MPPT ctrl & SmartSolar ctrl	Built-in	VE.Direct	Yes	Yes	L
150/70-Tr	No	12/24/36/48V	MPPT ctrl & SmartSolar ctrl	Built-in	VE.Direct	Yes	Yes	L
150/70-MC4	No	12/24/36/48V	MPPT ctrl & SmartSolar ctrl	Built-in	VE.Direct	Yes	Yes	L
150/70-Tr VE.Can	No	12/24/36/48V	MPPT ctrl & SmartSolar ctrl	Built-in	VE.Direct & VE.Can	Yes	Yes	L
150/70-MC4 VE.Can	No	12/24/36/48V	MPPT ctrl & SmartSolar ctrl	Built-in	VE.Direct & VE.Can	Yes	Yes	L
150/85-Tr VE.Can	No	12/24/36/48V	MPPT ctrl & SmartSolar ctrl	Built-in	VE.Direct & VE.Can	Yes	Yes	XL
150/85-MC4 VE.Can	No	12/24/36/48V	MPPT ctrl & SmartSolar ctrl	Built-in	VE.Direct & VE.Can	Yes	Yes	XL
150/100-Tr VE.Can	No	12/24/36/48V	MPPT ctrl & SmartSolar ctrl	Built-in	VE.Direct & VE.Can	Yes	Yes	XL
150/100-MC4 VE.Can	No	12/24/36/48V	MPPT ctrl & SmartSolar ctrl	Built-in	VE.Direct & VE.Can	Yes	Yes	XL
250/60-Tr	No	12/24/36/48V	MPPT ctrl & SmartSolar ctrl	Built-in	VE.Direct	Yes	Yes	L
250/60-MC4	No	12/24/36/48V	MPPT ctrl & SmartSolar ctrl	Built-in	VE.Direct	Yes	Yes	L
250/70-Tr	No	12/24/36/48V	MPPT ctrl & SmartSolar ctrl	Built-in	VE.Direct	Yes	Yes	L
250/70-MC4	No	12/24/36/48V	MPPT ctrl & SmartSolar ctrl	Built-in	VE.Direct	Yes	Yes	L
250/70-Tr VE.Can	No	12/24/36/48V	MPPT ctrl & SmartSolar ctrl	Built-in	VE.Direct & VE.Can	Yes	Yes	L
250/70-MC4 VE.Can	No	12/24/36/48V	MPPT ctrl & SmartSolar ctrl	Built-in	VE.Direct & VE.Can	Yes	Yes	L
250/85-Tr VE.Can	No	12/24/36/48V	MPPT ctrl & SmartSolar ctrl	Built-in	VE.Direct & VE.Can	Yes	Yes	XL
250/85-MC4 VE.Can	No	12/24/36/48V	MPPT ctrl & SmartSolar ctrl	Built-in	VE.Direct & VE.Can	Yes	Yes	XL
250/100-Tr VE.Can	No	12/24/36/48V	MPPT ctrl & SmartSolar ctrl	Built-in	VE.Direct & VE.Can	Yes	Yes	XL
250/100-MC4 VE.Can	No	12/24/36/48V	MPPT ctrl & SmartSolar ctrl	Built-in	VE.Direct & VE.Can	Yes	Yes	XL



Color Control GX Venus GX Cerbo GX Smart Battery Sense VE.Direct Bluetooth Smart Dongle VE.Direct to USB Interface

Application Examples

Motorhomes

Ambulances

Coffee cart Espresso

Systems

Accessories

Tools

Technical information

MultiPlus principle

Inverter/charger system with intelligent shore and generator power management

PowerControl: Dealing with limited generator or grid power all models in the MultiPlus range feature powerful battery chargers. When the largest model is working hard it can draw almost 10A from a 230V supply. Using the remote panel it is possible to 'dial-in' the maximum current that is available from mains or generator. The MultiPlus will then automatically regulate the charger taking account of other system AC loads and ensuring the charger only uses what is spare. This way it is possible to avoid tripping the mains power or overloading the generator.

PowerControl

Battery charger reduces its output, if required, to avoid overload of supply when system consumption is high.

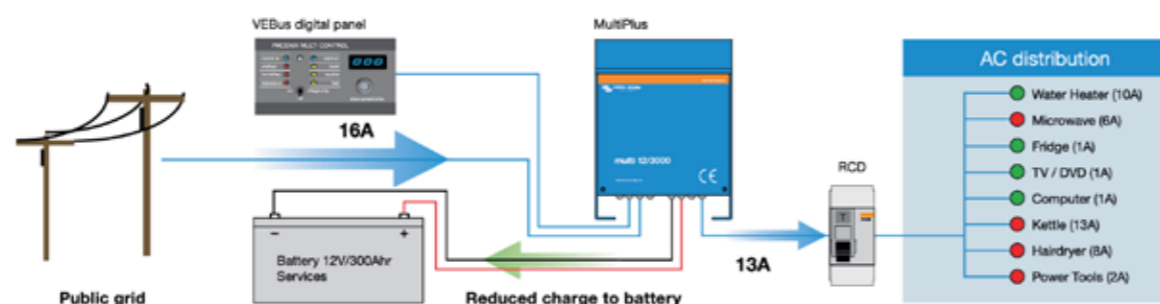

PowerAssist: Boosting the power available from mains or generator, an innovative feature of Multiplus. The feature that most distinguishes the MultiPlus from other inverter/chargers is PowerAssist. This feature takes the principle of PowerControl to a further dimension by allowing a MultiPlus to supplement the power available from mains or generator to 'assist' during periods of high demand. Peak power demand is almost always sustained only for short periods, either a few minutes (in the case of items like cooking appliances) or just a few seconds (in the case of the burst of energy needed to start an air-conditioning or refrigeration compressor).

With the capacity of the generator or mains power set on the remote panel, the MultiPlus detects when the load is becoming too much for the supply and will instantly provide the extra power required. When the demand has reduced, the unit returns to charging the battery. This feature is equally effective in large and small systems helping to reduce the required generator capacity or to achieve greater things with limited mains power. There is even a special feature to enable the MultiPlus/Quattro to work perfectly with portable generators.

PowerAssist

Inverter boosts incoming power, if required, to avoid overload of supply when system consumption exceeds supply.

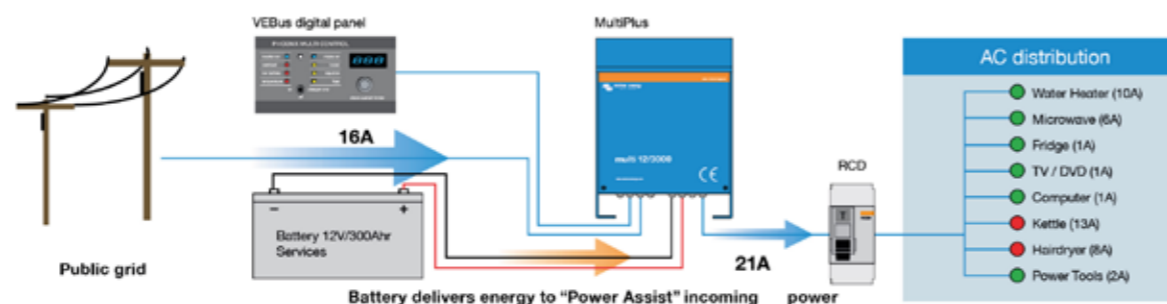

System application

Comfort system

Appliance	System
Lighting	Quattro 12/3000/120
Communication & navigation	BMV602-S battery monitor
Water heater	2x12V/200AH and 1X80AH batteries
Microwave oven	Digital control remote panel
2 ring induction hob	Alternator 12/150
Coffee machine/Kettle	DC Link Box
TV/DVD	Isolation transformer
Laptop	Cyrix battery separator
Small chargers (mobile phone, shaver etc.)	
Refrigerator and freezer	Solarpanel and MPPT Solar charger

Comfort Plus system

Appliance	System
Lighting	2 x Quattro 24/5000/120
Communication & navigation	VE-NET Battery controller
Water heater	4x12V/200AH and 1X80AH batteries
Electric gallery with 4 ring induction hob, microwave/combi oven, refrigerator, freezer, washer/dryer	Blue Power panel
Coffee machine and kettle	Alternator 12/150
TV/DVD	DC Link box
Multimedia PC	Isolation transformers
Small chargers (mobile phone, shaver etc.)	
Modest air-conditioning	Solarpanel and MPPT Solar charger

Comfort system - 7 kVa (30a) capacity

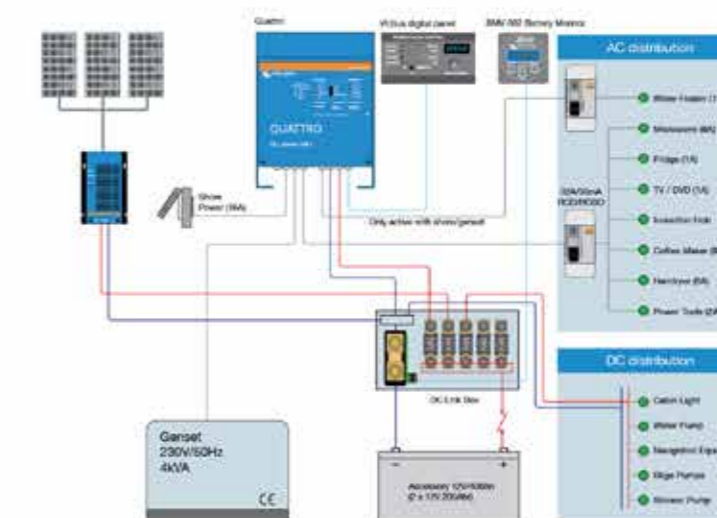

Comfort plus system - 25 kVa capacity

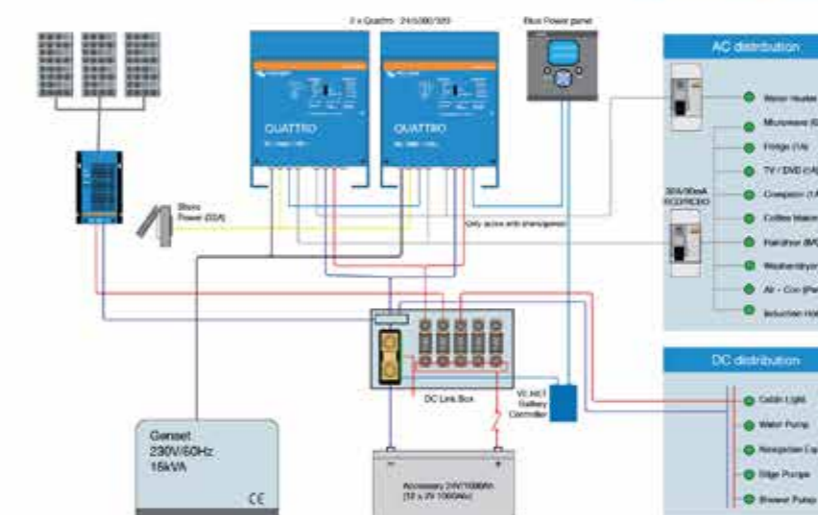

About Victron Energy

With over 46 years of experience, Victron Energy enjoys an unrivalled reputation for technical innovation, reliability and quality. Victron is a world leader in the supply of self-supporting electrical power. Our products have been designed to meet the most demanding situations faced by a diversity of craft, recreational and commercial alike. Victron's ability to meet the demand for customized off-grid systems is unprecedented. Our product range includes sine wave inverters and inverterchargers, battery chargers, DC/DC converters, transfer switches, gel and AGM batteries, alternators, battery monitors, solar charge regulators, solar panels, complete network solutions and many other innovative solutions.

World-wide service and support

Having served the off-grid, industrial and vehicle markets as well as both the commercial and leisure marine sectors for over 46 years, Victron has an established network of dealers and distributors covering the whole world. Our customer base is such that providing prompt and competent local service is essential.

This is reflected in the capabilities of our support network. Our flexible approach to service support and our commitment to quick turnaround for repairs is marketleading. There are countless examples of Victron products that have provided for decades of reliable service in the most demanding applications. This level of reliability combined with the highest level of technical know-how results in Victron Energy power systems that offer the very best value available.



Luxury camper from Vennegoor Installatie B.V.

